



515 Grove Street  
Suite 1B  
Haddon Heights, NJ 08035  
T: 856-547-0505  
F: 856-547-9174

[www.pennoni.com](http://www.pennoni.com)

*PROJECT MANUAL*

---

*WILLINGBORO PERFORMING ARTS CENTER*

*SOUND AND LIGHTING SYSTEMS*

*WILLINGBORO TOWNSHIP, BURLINGTON COUNTY, NJ*

*OWNER:*

---

Township of Willingboro  
1 Rev Dr Martin Luther King Jr. Drive  
Willingboro, NJ08046

A handwritten signature in black ink, appearing to read "Hugh J. Dougherty".

---

Hugh J. Dougherty, P.E.  
New Jersey License No. GE34634

*PROJ. NO. WTCEX 21015*  
September 18, 2024

ALL DOCUMENTS PREPARED BY PENNONI ASSOCIATES ARE INSTRUMENTS OF SERVICE IN RESPECT OF THE PROJECT. THEY ARE NOT INTENDED OR REPRESENTED TO BE SUITABLE FOR REUSE BY OWNER OR OTHERS ON EXTENSIONS OF THE PROJECT OR ON ANY OTHER PROJECT. ANY REUSE WITHOUT WRITTEN VERIFICATION OR ADAPTATION BY PENNONI ASSOCIATES FOR THE SPECIFIC PURPOSE INTENDED WILL BE AT OWNER'S SOLE RISK AND WITHOUT LIABILITY OR LEGAL EXPOSURE TO PENNONI ASSOCIATES; AND OWNER SHALL INDEMNIFY AND HOLD HARMLESS PENNONI ASSOCIATES FROM ALL CLAIMS, DAMAGES, LOSSES AND EXPENSES ARISING OUT OF OR RESULTING THEREFROM.

## TABLE OF CONTENTS

SECTION A	ADVERTISEMENT .....	A-1 TO A-2
SECTION B	INSTRUCTIONS TO BIDDERS .....	B-1 TO B-6
SECTION C	STATEMENT OF WORK .....	C-1 TO- C-2
SECTION D	GENERAL CONDITIONS.....	D-1-TO D-6
SECTION E	SPECIAL CONDITIONS .....	E-1 TO E-2
SECTION F	GENERAL PROVISIONS .....	F-1 TOF-24
SECTION G	GENERAL SPECIFICATIONS .....	01050-01710
SECTION H	TECHNICAL SPECIFICATIONS .....	
SECTION I	PROPOSAL.....	I-1 TO I-32
SECTION J	CONTRACT DOCUMENT/BOND.....	J-1 TO J-17

APPENDIX: NONE



## NOTICE - ADVERTISEMENT

Notice is hereby given that sealed bids will be received by the Township Clerk of the Township of Willingboro for “WILLINGBORO PERFORMING ARTS CENTER – SOUND AND LIGHTING UPGRADE” and will be opened and read in public at the Township of Willingboro Administrative Offices located at 1 Rev Dr Martin Luther King Jr Drive, Willingboro, New Jersey, on October 1, 2024 at 10:00 A.M. prevailing time.

The work includes the furnishing of all material and equipment set forth in these Specifications, consisting specifically of sound and lighting systems for the Willingboro Performing Arts Center. The proposed prices shall include all shipping, handling, taxes and fees. Quantities for the sought after equipment and materials (or equivalents) are summarized as follows:

### AUDIO:

Bid Item	Description	Manufacturer	Manufacturer Part Number	Qty
1	Speaker	RCF	GTX10	12
2	Speaker	RCF	GTS29	4
3	FlyBar	RCF	FL-B 006	3
4	Power Amp	RCF	XPS-16K-D	3
5	Audio Console	Midas	HD96-24-CC-IP	1
6	I/O Preamp Stage Box	Midas	DL231	3
7	I/O Preamp Stage Box	Midas	DL152	1
8	Audio Console	Midas	Heritage D HD96	1
9	I/O Stage box	Midas	DL231	3
10	I/O Stage box	Midas	DL152	1
11	AES50 Extender	Klark Teknik	DN9680	1
12	Speaker	RCF	NX12-SM	12
13	Wireless Microphone Receiver	Shure	ULXD4Q	2
14	Wireless Microphone	Shure	ULXD2/SM58	8
15	Antenna Splitter	Shure	UA844	1
16	Antenna Paddle	Shure	PA805SWB	2
17	Microphone	Shure	Beta 152	1
18	Microphone	Shure	SM57	4
19	Microphone	Shure	SM98	4
20	Microphone	Shure	SM81	3
21	Equipment Rack with 4 Drawers	Mid Atlantic	N/A	1
22	XLR Stage Snake	OnStage	N/A	5
23	Cable Package	OnStage	N/A	1
24	Mic Stand Package	OnStage	N/A	1
25	Power Sequencing	Furman	CN-20MP	10
26	Power Sequencing	Furman	CN-1800S	1
27	Power Sequencing	Furman	PS-REL AC	10

LIGHTING:

Bid Item	Description	Manufacturer	Manufacturer Part Number	Qty
28	Lighting Controller	Obsidian	NX2	1
29	Box Truss	Gamma	GT-SQ290	6
30	Light Fixture	Cameo	CLP2T	12
31	Light Fixture Lens	Cameo	CLP21530 LENS	12
32	Lighting Fixture	Cameo	Theatre Spot 200	6
33	Lighting Fixture	Cameo	Azor S2 / CLAZOR	8
34	Lighting Fixture	Chauvet Pro	Color-dash Par H18X	3
35	Hazer	Cameo	Instant Haze 1400 Pro	2
36	Cable Package	N/A	N/A	1
37	Power Sequencing	Furman	CN-20MP	10
38	Power Sequencing	Furman	CN-1800S	1
39	Power Sequencing	Furman	PS-REL AC	10
40	Stage Lighting Truss System	Gamma	GT-SQ290	16
41	Stage Lighting Truss System	Gamma	G-Truss Ground	4

Specifications, and forms of bid for the proposed work prepared by Pennoni Associates, Municipal Engineer, and approved by the Township of Willingboro have been filed in the office of said ENGINEER, at 515 Grove Street, Suite 1B, Haddon Heights, New Jersey 08035, and may be inspected by prospective bidders during regular business hours. Digital copies of the Bid Documents will be provided and may be obtained at no cost by contacting Pennoni Associates, either Alicia Borstad (by e-mail at [ABorstad@Pennoni.com](mailto:ABorstad@Pennoni.com)), or Danielle Downes (by e-mail at [DDownes@Pennoni.com](mailto:DDownes@Pennoni.com)). Should interested bidders not have the ability to handle electronic download sets, a set may be arranged to be sent by calling 856-547-0505.

Submission of Bid: All bids must be submitted on the bid proposal forms approved and provided for by the bid specifications in order to be considered. Bidders are to provide one (1) clearly sealed and marked ORIGINAL, one (1) Clearly marked COPY and one (1) electrical copy on USB drive. Please have each item on checklist color tabbed and numbered in your bid packet for a more time efficient packet review.

Bids must be made on the standard Proposal form in the manner designated therein, and must be enclosed in a sealed envelope bearing the name and address of the bidder and the name of the project on the outside, addressed to Willingboro Township, and must be accompanied by a Certified Check, Bid Bond or Cashier's Check drawn to the order of Willingboro Township for ten percent (10%) of the total amount bid, provided said security need not be more than \$20,000.00. All bid guarantees shall be accompanied by an executed consent from an approved surety company, licensed to conduct business in the State of New Jersey, agreeing to furnish the required Performance, Payment and Maintenance Bond upon the award of contract.

The signed Proposal forms and bid security must be delivered to the place on or before the hour named above. The accepted bidder must sign the contract within ten (10) days after the Notice of Award or forfeit his bid security. Bid securities will be returned to all but the three apparent lowest responsible bidders. All other bid securities will be returned after awarding and signing of the contract and approval of the Contractor's Performance Bond.

The Township will not assume responsibility for bids mailed in.

Bidders are required to comply with the requirements of N.J.S.A 10:5-31 et seq. and N.J.A.C. 17:27.

The right is reserved to reject any or all Proposals, in whole or in part, or to make awards to such bidder or bidders, who, in the judgment of the Township of Willingboro makes the most advantageous bid and to waive such informalities as may be permitted by law.

BY ORDER OF THE TOWNSHIP COMMITTEE OF THE TOWNSHIP OF WILLINGBORO.

Everett Falt  
Township Clerk





## SECTION B

### INSTRUCTIONS TO BIDDERS

#### INDEX

1. BIDDER'S RESPONSIBILITY / BID SCHEDULE
2. DELIVERY OF PROPOSALS
3. EXPLANATION TO BIDDERS
4. MODIFICATIONS TO SPECIFICATIONS -ADDENDA
5. BID GUARANTY
6. METHOD FOR SUBMITTING BIDS
7. BIDDER'S QUALIFICATIONS
8. BID OPENING PROCEDURE
9. COLLUSIVE BIDS
10. WITHDRAWAL OF BIDS
11. AWARD OF CONTRACT
12. EXECUTION OF CONTRACT
13. FAILURE TO EXECUTE CONTRACT
14. SUBLETTING OR ASSIGNING OF CONTRACT
15. REJECTION OF BIDS
16. PAYMENTS TO CONTRACTOR
17. TIME OF COMPLETION
18. RETURN TO BID GUARANTY
19. WAGE RATES
20. CHAPTER 33, P.L. 1977, c. 52:25-24.2
21. AFFIRMATIVE ACTION (N.J.S.A. 10:5-31 et seq., N.J.A.C. 17:27)

1. BIDDER'S RESPONSIBILITY / BID SCHEDULE

Each bidder shall familiarize himself with all of the attached forms, Instruction, General Conditions, Specifications, and Contract Drawings, as he will be held responsible to fully comply therewith.

Each bidder must attend a mandatory pre-bid meeting to acquaint himself with conditions affecting the work.

a. Bid Schedule:

- Public Notice – September 20, 2024
- Bid Opening – October 1, 2024, 10 AM

2. DELIVERY OF PROPOSALS

It is the responsibility of the bidder to deliver his bid prior to the time of opening, regardless of what medium he uses to deliver it. No bid shall be considered if it arrives after the time set for the receipt of bids. Envelopes containing proposals shall be sealed, addressed to the Owner at the location specified for the opening of bids and submitted on the Form of Proposal furnished herein. The envelope shall also bear the identification of the Project, Contract No. and date and time of bid opening.

3. EXPLANATION TO BIDDERS

Any explanation desired by bidders regarding the meaning or interpretation of the drawings and specifications must be requested to the ENGINEER in writing and with sufficient time allowed for a reply to reach them before the submission of their bids. Verbal explanations or instructions given before the award of the contract will not be binding. Any interpretation which may result in a substantial change in the Plans and/or Specifications and may have an effect on the prices bid therefore will be issued in the form of an addendum to all bidders, and its receipt by the bidder shall be acknowledged.

4. MODIFICATIONS TO SPECIFICATIONS - ADDENDA

The right is reserved, as the interest of the OWNER may require, to revise or amend the specifications and/or drawings prior to the date set for opening bids. Such revisions and amendments, if any, will be announced by an addendum or addenda. Copies of such addenda as may be issued will be furnished to all prospective bidders. If the revisions and amendments are of a nature which required material changes in quantities or prices bid, or both, the date set for opening bids may be postponed by such number of days as in the opinion of the ENGINEER will enable bidders to revise their bids. In such case, the addendum will include an announcement of the new date for opening bids.

Bidders shall acknowledge receipt of all addenda which have been issued during period of bidding and agree that said addenda shall become part of this contract. The bidders shall list

the numbers and issuing dates of the addenda received and acknowledge same on the appropriate page provided in the Form of Proposal section of these specifications.

5. BID GUARANTY

Each bid must be accompanied by a cashier's check, certified check, or bid bond duly executed by the bidder as principal and an acceptable surety company, such guarantee to be made payable to the OWNER in the amount of ten percent (10%) of the bid, but not in excess of \$20,000.00. All bid guarantees shall be accompanied by an executed consent from an acceptable surety company, agreeing to furnish the required Performance and Maintenance Bonds upon the award of Contract. The surety company shall be one licensed to conduct business in the State of New Jersey.

6. METHOD FOR SUBMITTING BIDS

No proposal will be considered unless submitted upon the proposal form for the project. The blank spaces in the proposal form shall be filled in correctly, where indicated, for each and every item for which a description is given, and the bidder must state the prices (which shall be written in ink, in words and numerals) for which he proposes to do each part of the work contemplated. In case of discrepancy, the written words shall be considered as being the bid price.

The bidder shall sign his proposal correctly. If the proposal is made by an individual, in addition to his signature, his complete post office address should be given. If made by a firm or partnership, the complete post office address of each member of the firm or partnership must be given. If made by a corporation, the person signing the proposal should be the President or Vice President and the Secretary Treasurer or Treasurer of the corporation; otherwise, the signing individual's certificate or authority to execute such papers should accompany the proposal.

If bidder has been incorporated in some state other than New Jersey, bidder shall state whether the corporation is registered to do business in New Jersey. If bidder operates under an assumed or fictitious name, he shall state whether such name has been registered in New Jersey.

No contract will be awarded to a bidder who is a foreign corporation or operating under a fictitious or assumed name unless he has complied or agreed to comply, with the proper registration under the laws of New Jersey.

7. BIDDER'S QUALIFICATIONS

The bidder shall submit with his proposal a statement of facts in detail as to his previous experience in performing similar or comparable work, and of his business and technical organization and financial resources and plant available and to be used in performing the contemplated work.

Upon request, bidder shall prove that he has liquid assets, available for the project upon which he is bidding in an amount equal to fifteen percent (15%) of the first \$100,000.00 of the amount of the bid plus ten percent (10%) of the next \$900,000.00 plus five percent (5%) of the remainder of the bid.

None of the following will be considered as liquid assets:

- (a) Capital Stock of the Contractor.
- (b) Accounts receivable against which assignments have been made.
- (c) Equity in real estate.
- (d) Life Insurance.
- (e) Reserve representing pre-payment of taxes or other expenses.
- (f) Deposits held as security for other contracts.
- (g) Capital of proposed sub-contractors.

In addition to the financial and experience qualifications, the bidder may be required to prove to the satisfaction of the Owner that he has successfully completed a contract for similar work in an amount of not less than seventy-five percent (75%) of the amount of the proposed contract.

The foregoing will guide the Owner in determining the responsibility of the bidder, but additional information may be requested by the Owner whenever in its judgment such information is necessary to determine the responsibility of the bidder.

In the event the bidder fails, refuses or neglects to submit any required information within the reasonable time stated in any request therefore or fails to qualify as a responsible bidder, his proposal guaranty shall be forfeited to the use of the Owner, not as a penalty, but as liquidated damages.

8. BID OPENING PROCEDURE

Sealed proposals on projects will be received by the Owner at the designated place and until the time stated in the "Advertisement" at which time all proposals will be publicly opened and read. The Owner reserves the right to reject any or all bids, or parts thereof, as it may deem best for the interest of the Owner.

9. COLLUSIVE BIDS

The proposal of any bidder or bidders who engage in collusive biddings shall be rejected. Any bidder who submits more than one proposal in such manner as to make it appear that the proposals submitted are on a competitive basis from different parties shall be considered a collusive bidder. The Owner may reject the bid proposals of any collusive bidder upon bid opening. However, nothing in this section shall prevent a bidder from superseding a bid proposal by a subsequent proposal delivered prior to bid opening which expressly revokes the previous bid.

10. WITHDRAWAL OF BIDS

Bids may be withdrawn on written or telegraphic request received from bidders prior to the time fixed for opening. Negligence on the part of the bidder in preparing the bid confers no right for the withdrawal of the bid after it has been opened.

11. AWARD OF CONTRACT

The Owner's Solicitor shall have the right to waive informalities in the bids when such waiver is in the best interest of the Owner.

The contract will be awarded to the lowest responsible bidder within (60) days of the bid opening or all bids will be rejected. Thirty (30) day extensions of time may be made by the mutual written consent of the Owner and the lowest responsible bidder.

If the lowest bidder withdraws his bid, refuses award of contract, the Owner shall have the right to award to contract to the next lowest responsible bidder or to reject all bids and re-bid the contract.

12. EXECUTION OF CONTRACT

The bidder to whom award is made shall, within ten (10) days of his notice of award, execute the Contract Documents and furnish a Performance Bond in an amount equal to the full amount of the Contract. The Bond must be drawn by an acceptable surety company in the full amount of the contract.

No proposals or awards shall be considered binding upon the Owner unless and until the contract documents are properly executed by both parties.

13. FAILURE TO EXECUTE CONTRACT

If the lowest responsible bidder to whom the contract is awarded fails to submit bonds or execute the contract within the time specified, the amount of the proposal guaranty shall be paid to the Owner as liquidated damages. In such case the Owner, at his discretion may award the contract to the next lowest responsible bidder or reject all bids.

14. SUBLETTING OR ASSIGNING OF CONTRACT

The Contractor shall not sublet, sell, transfer, assign or otherwise dispose of the contract or any portion thereof, of his right, title or interest therein, without the written consent of the Owner.

15. REJECTION OF BIDS

The OWNER reserves the right to reject any and all bids when such rejection is in the interest of the OWNER; to reject the bid of a bidder who has previously failed to perform properly or complete on time contracts of a similar nature; and to reject the bid of a bidder who is not, in the opinion of the ENGINEER, in a position to perform the contract.

The OWNER further reserves the right to reject bids which are unbalanced if, in the opinion of the ENGINEER, said unbalanced bids could cause undue increases in contract costs.

16. PAYMENTS TO CONTRACTOR

The Contractor will prepare and submit to the ENGINEER a written pay request based on material and equipment delivered during the pay period; ninety percent (90%) of such estimate shall be due the Contractor as payment on account within forty five (45) days after submittal to the ENGINEER barring any measurement disputes between the ENGINEER and the Contractor. The balance of ten percent (10%) of a monthly estimate shall be withheld until final acceptance of the completed work. However, when the total contract price exceeds One Hundred Thousand Dollars (\$100,000.00), then ninety-eight percent (98%) of such estimate shall be due the Contractor as above specified. The balance of two percent (2%) of a monthly estimate shall be withheld until final acceptance of the completed work, or in lieu of the two percent (2%) cash retainage the Contractor may agree to deposit negotiable bearer bonds of the State of New Jersey, or negotiable bearer bonds or notes of any political subdivision of the State, the value of which is equal to two percent (2%) of said estimate, provided they are delivered directly to and approved by the OWNER. The value of a bond or note shall mean par value or current market value, whichever is lower. The balance of a monthly estimate withheld and the bonds or notes deposited, and any interest accruing on such bonds or notes, shall be returned to the Contractor upon final acceptance of the completed work. Any interest accruing on cash payments withheld shall be credited to the OWNER.

17. TIME OF COMPLETION

Should all the work under the Contract not be completed within the time specified herein from notice to proceed, there shall be deducted and retained out of the payments which may be due the contractor, the sum as designated in the Proposal for each and every calendar day beyond the time stipulated, excepting Sundays and Legal Holidays, not as a penalty but as liquidated damage for engineering or other expenses.

18. RETURN OF BID GUARANTY

After bids are opened and read, bid securities will be returned to all but the three (3) apparent lowest responsible bidders on each contract. Those receiving returned bid securities must sign receipt for same. All other bid securities will be returned after the signing of a formal contract.

19. WAGE RATES

Not applicable.

20. CHAPTER 33, P.L. 1977, C.52:25-24.2

This Contract is subject to the Act requiring corporation and partnership bidders for State, County, Municipal or School District Contracts to submit a list of the names and addresses of all stockholders owning ten percent (10%) or more of their stock, or ten percent (10%) or more of the stock of their corporate stockholders, or in the case of partnership, the names and addresses of those partners owning ten percent (10%) or greater interest therein.

21. AFFIRMATIVE ACTION (N.J.S.A. 10:5-31 et seq., N.J.A.C. 17:27)

If awarded a contract, your company/firm will be required to comply with the requirements of N.J.S.A. 10:5-31 et seq. and N.J.A.C. 17:27. Details for compliance with the Affirmative Action Regulations are provided in the GENERAL PROVISIONS under Mandatory Equal Opportunity Language.

END OF SECTION





## SECTION C STATEMENT OF WORK

### 1. GENERAL

The work includes the furnishing of all material and equipment set forth in these Specifications, consisting specifically of sound and lighting systems for the Willingboro Performing Arts Center. The proposed prices shall include all shipping, handling, taxes and fees.

### 2. DESCRIPTION OF WORK

The proposed prices shall include all shipping, handling, taxes and fees. Quantities for the sought after equipment and materials (or equivalents) are summarized as follows:

AUDIO:

Bid Item	Description	Manufacturer	Manufacturer Part Number	Qty
1	Speaker	RCF	GTX10	12
2	Speaker	RCF	GTS29	4
3	FlyBar	RCF	FL-B 006	3
4	Power Amp	RCF	XPS-16K-D	3
5	Audio Console	Midas	HD96-24-CC-IP	1
6	I/O Preamp Stage Box	Midas	DL231	3
7	I/O Preamp Stage Box	Midas	DL152	1
8	Audio Console	Midas	Heritage D HD96	1
9	I/O Stage box	Midas	DL231	3
10	I/O Stage box	Midas	DL152	1
11	AES50 Extender	Klark Teknik	DN9680	1
12	Speaker	RCF	NX12-SM	12
13	Wireless Microphone Receiver	Shure	ULXD4Q	2
14	Wireless Microphone	Shure	ULXD2/SM58	8
15	Antenna Splitter	Shure	UA844	1
16	Antenna Paddle	Shure	PA805SWB	2
17	Microphone	Shure	Beta 152	1
18	Microphone	Shure	SM57	4
19	Microphone	Shure	SM98	4
20	Microphone	Shure	SM81	3
21	Equipment Rack with 4 Drawers	Mid Atlantic	N/A	1
22	XLR Stage Snake	OnStage	N/A	5
23	Cable Package	OnStage	N/A	1
24	Mic Stand Package	OnStage	N/A	1
25	Power Sequencing	Furman	CN-20MP	10
26	Power Sequencing	Furman	CN-1800S	1
27	Power Sequencing	Furman	PS-REL AC	10

LIGHTING:

Bid Item	Description	Manufacturer	Manufacturer Part Number	Qty
28	Lighting Controller	Obsidian	NX2	1
29	Box Truss	Gamma		4
30	Light Fixture	Cameo	CLP2T	12
31	Light Fixture Lens	Cameo	CLP21530 LENS	12
32	Lighting Fixture	Cameo	Theatre Spot 200	6
33	Lighting Fixture	Cameo	Azor S2 / CLAZOR	8
34	Lighting Fixture	Chauvet Pro	Color-dash Par H18X	3
35	Hazer	Cameo	Instant Haze 1400 Pro	2
36	Cable Package	N/A	N/A	1
37	Power Sequencing	Furman	CN-20MP	10
38	Power Sequencing	Furman	CN-1800S	1
39	Power Sequencing	Furman	PS-REL AC	10
40	Stage Lighting Truss System	Gamma	GT-SQ290	16
41	Stage Lighting Truss System	Gamma	G-Truss Ground	4

1.3 SCHEDULE AND PHASING

The building will be live and in use by the Township and public during equipment and material delivery. It is anticipated that the work will be performed during normal work hours.

1.4 COORDINATION

In general, work shall be planned and coordinated through the office of the ENGINEER.

1.5 ACCESS

The building will be open to the Township and the public during the delivery of the goods. construction. Work areas must be kept neat and properly protected.

END OF SECTION

SECTION D  
GENERAL CONDITIONS

INDEX

1. SCOPE OF WORK
2. CHARACTER OF WORK AND MECHANICS
3. SITE INVESTIGATION
4. OPERATIONS AND STORAGE AREAS
5. PROGRESS CHARTS AND REQUIREMENTS FOR OVERTIME WORK
6. SUBCONTRACTORS
7. QUALITY OF ARTICLES, MATERIALS AND EQUIPMENT
8. PROTECTION OF MATERIAL AND WORK
9. PROTECTION OF VEGETATION
10. POSSESSION PRIOR TO COMPLETION
11. SUSPENSION OF WORK
12. CLEANING UP
13. BONDS
14. INSPECTION
15. INSTALLATION, OPERATION AND MAINTENANCE MANUALS



## GENERAL CONDITIONS

### 1. SCOPE OF WORK

The work includes the furnishing of all material and equipment set forth in these Specifications, consisting specifically of sound and lighting systems for the Willingboro Performing Arts Center. The proposed prices shall include all shipping, handling, taxes and fees.

### 2. CHARACTER OF WORK AND MECHANICS

The work shall be executed in the best and most workmanlike manner by qualified, careful and efficient mechanics in strict accordance with the Specifications.

### 3. SITE INVESTIGATION

The Contractor acknowledges that he has satisfied himself as to the nature and location of the work, the general and local conditions, including but not restricted to those bearing upon transportation, disposal, handling and storage of materials, availability of labor, water, electric power, roads and uncertainties of weather, river stages, tides or similar physical conditions at the site, the conformation and conditions of the ground, the character of equipment and facilities needed preliminary to and during the prosecution of the work. The Contractor further acknowledges that he has satisfied himself as to the character, quality and quantity of surface and subsurface materials or obstacles to be encountered insofar as this information is reasonably ascertainable from an inspection of the site, including all exploratory work done by the ENGINEER, as well as from information presented by the drawings and specifications made a part of this contract. Any failure by the Contractor to acquaint himself with the available information will not relieve him from responsibility for estimating properly the difficulty or cost of successfully performing the work. The OWNER assumes no responsibility for any conclusions or interpretations made by the Contractor on the basis of the information made available by the ENGINEER. The OWNER also assumes no responsibility for any understanding or representations made by its officers or agents during or prior to the execution of this contract, unless (1) such understanding or representations are expressly stated in the contract, and (2) the contract expressly provides that the responsibility therefore is assumed by the OWNER representations.

4. OPERATIONS AND STORAGE AREAS

- a. All operations of the Contractor (including storage of materials) shall be confined to areas approved by the ENGINEER. No unauthorized or unwarranted entry upon or passage through, or storage or disposal of materials shall be made upon private premises. The Contractor shall be liable for any and all damage caused by him to such private premises. The Contractor shall hold and save the OWNER, ENGINEER and their officers and agents free and harmless from liability of any nature or kind arising from any use, trespass or damage occasioned by his operations on premises of third persons.
- b. Temporary buildings (storage sheds, shops, offices, etc.) may be erected by the Contractor only with the approval of the ENGINEER, and shall be built with labor and materials furnished by the Contractor without expense to the OWNER. Such temporary buildings and/or utilities shall remain the property of the Contractor and will be removed by him at his expense upon the completion of the work. With the written consent of the ENGINEER, such buildings and/or utilities may be abandoned and need not be removed.
- c. The Contractor shall, under regulations prescribed by the ENGINEER, use only established roadways or construct and use such temporary roadways as may be approved by the ENGINEER. Where materials are transported in the prosecution of the work, vehicles shall not be loaded beyond the loading capacity recommended by the manufacturer of the vehicle or prescribed by any federal, state or local law or regulation. When it is necessary to cross curbs or sidewalks, protection against damage shall be provided by the Contractor, and any damaged roads, curbs or sidewalks shall be repaired by, or at the expense of, the Contractor.

5. PROGRESS CHARTS AND REQUIREMENTS FOR OVERTIME WORK

- a. The Contractor shall, within five (5) days after date of notice to proceed, prepare and submit to the ENGINEER for approval a practical schedule showing the date on which he will start the several salient features (including procurement of materials, plant and equipment) and the contemplated dates for completing same.
- b. If, in the opinion of the ENGINEER, the Contractor falls behind the progress schedule, the Contractor shall take such steps as may be necessary to improve his progress, and the ENGINEER may require him to increase days of work, and to submit for approval such supplementary schedule or schedules in chart form as may be deemed necessary to demonstrate the manner in which the agreed rate of progress will be regained, all without additional cost to the OWNER.
- c. Failure of the Contractor to comply with the requirements of the ENGINEER under the provision shall be grounds for determination by the ENGINEER that the Contractor is not prosecuting the work with such diligence as will insure completion

within the time specified. Upon such determination, the ENGINEER may terminate the Contractor's right to proceed with the work, or any separable part thereof, in accordance with the delays - damage clause of the contract.

6. SUBCONTRACTORS

Within seven (7) days after the award of any subcontract, the Contractor shall deliver to the ENGINEER a statement setting forth the name and address of subcontractors. If for sufficient reason, at any time during the progress of the work, the ENGINEER and OWNER determine that any subcontractor is undesirable, they will notify the Contractor accordingly and immediate steps will be taken for cancellation of such subcontract. Subletting by subcontractors shall be subject to the same regulations. Nothing contained in this contract shall create any contractual relation between the subcontractor and the OWNER and/or ENGINEER.

7. QUALITY OF ARTICLES, MATERIALS AND EQUIPMENT

- a. Articles, materials and equipment to be incorporated into the work under the contract shall be new and unused unless otherwise specified; and where required to conform to standard specifications of the ENGINEER or other authorities incorporated by reference, will conform to the respective editions, including amendments specified; or where the editions are not specified, will conform to the editions, including amendments in effect on the date of the Invitation for Bids.
- b. Any samples and descriptive data required shall:
  1. Be submitted within the time specified in these specifications, or, if no time be specified, within a reasonable time before use to permit inspection and testing.
  2. Be shipped, prepaid and delivered, as specified in these specifications, or as directed by the ENGINEER.
  3. Be properly marked to show the name of the material, trade name of manufacturer, place of origin, name and location of the project where the material represented by the sample is to be used, and the name of the contractor submitting the sample.
- c. Samples not subject to destructive tests may be retained until the completion of the work, but thereafter will be returned to the Contractor, if he so requests, in writing, at his own expense. Failure of any sample to pass the specified requirements will be sufficient cause for refusal to consider further any sample from the same manufacturer whose material failed to pass the tests.

8. PROTECTION OF MATERIAL AND WORK

The Contractor shall at all times protect and preserve all materials, supplies and equipment of every description (including property which may be OWNER furnished or owned) and all work performed. All reasonable requests of the ENGINEER to enclose or specially protect such property shall be complied with. If, as determined by the ENGINEER, material, equipment, supplies and work performed are not adequately protected by the Contractor, such property may be protected by the OWNER and the cost thereof may be charged to the Contractor or deducted from any payments due to him.

9. PROTECTION OF VEGETATION

- a. The Contractor will preserve and protect all existing vegetation such as trees, shrubs and grass on or adjacent to the site which do not unreasonably interfere with the construction as may be determined by the ENGINEER. The Contractor will be responsible for all unauthorized cutting or damaging of trees and shrubs, including damage due to careless operation of equipment, stockpiling of materials, or tracking of grass areas by equipment.
- b. Care will be taken by the Contractor in felling trees authorized for removal to avoid any unnecessary damage to vegetation that is to remain in place. Any limbs or branches of trees broken during such operations shall be trimmed with a clean cut and painted with an approved tree pruning compound. The Contractor will be liable for, or may be required to replace or restore at his own expense, all vegetation destroyed or damaged.
- c. Protect existing structures and other property at site or adjacent thereto, including walks, pavements and roadways.
- d. Promptly remedy all damage or loss, at no expense to the Owner.

10. POSSESSION PRIOR TO COMPLETION

The OWNER shall have the right to take possession of or use any completed or partially completed part of the work. Such possession or use shall not be deemed an acceptance of any work not completed in accordance with the contract. If such prior possession or use by the OWNER delays the progress of the work or causes additional expenses to the Contractor, an equitable adjustment in the contract price and/or the time of completion will be made and the contract shall be modified in writing accordingly.

11. SUSPENSION OF WORK

The ENGINEER may order the Contractor to suspend all or any part of the work for such period of time as may be determined by them to be necessary or desirable for convenience of the OWNER. Unless such suspension unreasonably delays the progress of the work and



causes additional expense to the Contractor, no increase in contract price will be allowed. In the case of suspension of all or any part of the work for an unreasonable length of time, causing additional expense not due to the fault or negligence of the Contractor, the ENGINEER shall make an adjustment in the contract price in the amount of the additional proper expense and modify the contract accordingly. An extension of time for the completion of the work in the event of any such suspension will be allowed the Contractor, providing, however, that the suspension was not due to the fault or negligence of the Contractor.

12. CLEANING UP

The Contractor shall at all times keep the construction area, including storage areas used by him, free from accumulations of waste materials or rubbish and prior to completion of the work remove the rubbish from the premises. Upon completion of the construction, the Contractor shall leave the work and premises in a clean, neat and workmanlike condition satisfactory to the ENGINEER.

13. BONDS

- a. Performance. The Contractor shall furnish a performance bond with good and sufficient surety or sureties acceptable to the OWNER in connection with the performance of the work under this Agreement. The penal sum of such performance will be one hundred percent (100%) of the contract price.
- b. Any bonds required hereunder will be dated as of the same date as the contract and will be furnished by the Contractor to the OWNER at the time the contract is executed, and must be accompanied by a Power of Attorney Certificate and Financial Statement.

14. INSPECTION

The work is subject to inspection by the ENGINEER or their appointed inspectors to insure strict compliance with the terms of the contract. No inspector is authorized to change any provision of the specifications without written authorization of the ENGINEER, nor shall the presence or absence of an inspector relieve the Contractor from any requirements of the contract. As soon as practicable after the completion of the entire work, or any divisible part thereof as may be designated in these specifications, an examination thereof will be made by the ENGINEER at the site of the work. If such work is found to comply fully with the requirements of the contract, it will be accepted, and final payment therefore will be made in accordance with the clause of the contract entitled, "Payments to Contractors."

15. INSTALLATION, OPERATION AND MAINTENANCE MANUALS

Upon completion of all work the Contractors will furnish six (6) copies of Record Data and Installation, Operation and Maintenance Manuals for all Mechanical and Electrical Equipment. Maintenance Manuals shall include complete wiring diagrams, normal causes of failures and how to remedy them, with complete instructions on maintenance of equipment. Delivery of these manuals will be made to the ENGINEER prior to submittal of semi-final estimate for payment by the Contractor.

SECTION E  
SPECIAL CONDITIONS

INDEX

1. ON-SITE CONDITIONS
2. UTILITIES
3. RESPONSIBILITY REGARDING EXISTING UTILITIES, PIPES AND STRUCTURES
4. STORING OF MATERIALS
5. WATER SUPPLY
6. PRECONSTRUCTION CONFERENCE
7. COMMUNICATIONS
8. EXECUTION, CORRELATION AND INTENT OF DOCUMENTS



1. ON-SITE CONDITIONS

Meet following conditions during the progress of contract as specified in the New Jersey Department of Transportation Standard Specifications, as currently amended.

- a. Public Safety and Convenience
- b. Sanitary, Health and Safety Provisions
- c. Final Clean Up
- d. Equipment

2. UTILITIES

Adhere to the Standard Specifications regarding location of and construction around public utilities, including those publicly and privately owned.

Permit owners of utilities, or their agents, access to site work at all times, in order to relocate or protect their facilities. Cooperate and coordinate with utility owners in performing this work.

Notify utility owners not less than ten (10) days in advance of any work that will endanger or affect their facilities.

Separate payment will not be made for protection and preservation of utilities and cooperation and coordination with their owners. Include all such costs in unit price bid for the various items of contract as listed in Proposal.

Any public utility facilities being constructed under this contract shall be subject to inspection by the utility owner during construction, and the utility owner shall be given the opportunity to inspect material to be used in reference to the specifications and plan details applying to such materials.

Comply with requirements of Blasting--Excavating--Restrictions, State of New Jersey--Laws of 1964 Section I, P.L. 1964c 53 (C.2A:170-69.4), as currently amended, which generally requires notification of gas company before any work commences within 200 feet of their services.

Contact the following a minimum of ten (10) days prior to construction:

- 1. "One Number to Call System": (800)272-1000

The Contractor is advised that the "One Number to Call System" Service noted above does not necessarily include all utilities in the construction area. Some utility companies (for example, New Jersey-American Water Company) may require separate notification.

3. RESPONSIBILITIES REGARDING EXISTING UTILITIES, PIPES AND STRUCTURES

Contractor shall be held responsible for any damages to and for protection of all existing utilities and structures.

4. STORING OF MATERIALS

All materials required in the work may be stored on site subject to approval by the ENGINEER. All such materials, tools, and machinery stored upon public thoroughfares shall be provided with approved warning lights or other devices to protect pedestrian and vehicular traffic.

5. WATER SUPPLY

Not applicable.

6. PRECONSTRUCTION CONFERENCE

Not applicable.

7. COMMUNICATIONS

Forward all communications to OWNER through ENGINEER.

8. EXECUTION, CORRELATION AND INTENT OF DOCUMENTS

The Contract Documents as defined in the General Provisions are complementary, and what is called for by anyone shall be as binding as if called for by al

SECTION F  
GENERAL PROVISIONS

INDEX

1. DEFINITIONS
2. EXTENT OF CONTRACT
3. OBLIGATIONS OF CONTRACTOR
4. ABSENCE OF CONTRACTOR
5. NOTICES TO CONTRACTOR
6. INSPECTION
7. ENGINEER'S STATUS
8. ENGINEER'S DECISION
9. ACCESS TO WORK
10. COMPETENT WORKERS TO BE EMPLOYED
11. LAW AND ORDINANCES
12. PERMITS
13. LABOR-EMPLOYMENT-WAGES-HOURS
14. WORKERS COMPENSATION
15. PUBLIC LIABILITY, PROPERTY AND AUTOMOBILE INSURANCE
16. SOCIAL SECURITY ACT
17. ASSIGNMENT OF CONTRACT
18. ROYALTIES AND PATENTS
19. CLAIMS FOR LABOR, MATERIALS AND DAMAGES
20. ACCIDENTS AND CLAIMS TO BE GUARDED AGAINST
21. STATEMENT OF QUANTITIES
22. MATERIALS AND WORK
23. DEFECTIVE WORK OR MATERIALS

GENERAL PROVISIONS (Continued)

INDEX (Continued)

24. PERMISSIBLE CHANGES AND VARIATIONS IN THE WORK
25. EXTRA WORK
26. OTHER CONTRACTS
27. SUSPENSION OF WORK
28. REMEDIES
29. ABANDONMENT OF WORK
30. FORFEITURE OF CONTRACT
31. COMPLETION OF CONTRACT BY OWNER
32. COMPLETION OF WORK DEFINED
33. TIME FOR COMPLETION
34. DELAYS AND EXTENSION OF TIME FOR COMPLETION
35. PRICES
36. APPROVAL AND ACCEPTANCE OF WORK
37. ESTIMATES AND PAYMENT - PARTIAL AND FINAL
38. LIENS
39. CONTRACTOR'S CLAIM FOR DAMAGES
40. NO WAIVER OF CONTRACT
41. NO ESTOPPEL
42. SUBLETTING
43. RELATIONS OF CONTRACTOR AND SUBCONTRACTOR
44. WAGE RATES
45. MANDATORY EQUAL EMPLOYMENT OPPORTUNITY LANGUAGE (N.J.S.A. 10:5-31 et seq., N.J.A.C. 17:27)



## GENERAL PROVISIONS

### 1. DEFINITIONS

Wherever the term "OWNER" is used herein, it shall refer to the Municipality, the party of the first part to this Agreement.

Wherever the term "Contractor" is used herein, it shall refer to and designate the party of the second part to this Agreement, or his or their legal representative, successors or assigns.

Wherever the term "ENGINEER" is used herein, it shall refer to and designate the ENGINEER duly authorized by the OWNER to approve the construction of the improvements contemplated herein, or the duly appointed assistant or representative of said ENGINEER. ENGINEER as referenced in STANDARD SPECIFICATIONS, shall be interpreted to mean the ENGINEER duly authorized by the OWNER to observe the construction of the improvements contemplated herein, or the duly appointed assistant or representative of said ENGINEER.

Wherever the terms "Mayor" and "Clerk" are used herein, they shall refer to and designate the Mayor and Clerk of the Municipality.

Wherever the term "As Designated" is used herein, it shall be held to refer to information or directions indicated on the contract drawings or in the specifications covering the construction of the improvements contemplated herein.

Wherever the term "Approved" is used herein, it shall be held, unless otherwise specified, to mean as approved by the ENGINEER. Similar use will be made of the terms "Directed," "Required," "Permitted" and words of like import.

The Contract Documents consist of Advertisement Instructions to Bidders, Statement of Work, General Conditions, Special Conditions, General Provisions, General Specifications, Proposal, Contract Documents, Wage Rate Determinations and Plans, including all modifications incorporated in the documents before their execution.

The term "Subcontractor" as employed herein, includes only those having a direct contract with the Contractor, and it includes one who furnishes material worked to a special design according to the Plans and Specifications of this work, but does not include one who merely furnishes material not so worked.

"Written Notice" shall be deemed to have been duly served if delivered in person to the authorized agent of the Contractor, such as superintendent or foreman in charge of work or to a member of the firm or to an officer of the corporation for whom it is intended, or if delivered at or sent by registered mail to the last business address known to him who gives the notice.

"Section" shall refer to either the specification section of these specifications in which case it will be followed by the term "of these specifications" or a specified section of the Standard

Specifications in which case it will be followed by the term "of the STANDARD SPECIFICATIONS".

"Commissioner" as referenced in STANDARD SPECIFICATIONS shall be interpreted to mean ENGINEER.

"Department" as referenced in STANDARD SPECIFICATIONS shall be interpreted to mean the ENGINEER duly authorized by the OWNER to observe the construction of the improvements contemplated herein, or the duly appointed assistant or representative of said ENGINEER.

"Provide" shall be interpreted to mean to furnish and install complete.

"Standard Specifications", the New Jersey Department of Transportation Standard Specifications for Road and Bridge Construction, dated 2007, and all amendments thereto.

"State", as referenced in STANDARD SPECIFICATIONS shall be interpreted to mean OWNER.

## 2. EXTENT OF CONTRACT

The Advertisement, Instructions to Bidders, Proposals, Bonds, General Specifications and Contract Drawings are, and shall be taken to be a part of this contract. All work and materials mentioned in the specifications and not shown on the drawings, and all work and materials shown on the drawings and not mentioned in the specifications, and all work and materials necessary for the completion of the work according to the true intent and meaning of the contract drawings and specifications, shall be furnished, performed and done as if the same were both mentioned in the specifications and shown on the drawings. In case of disagreement between the plans and specifications, the ENGINEER will decide which shall prevail and the Contractor shall proceed in accordance with the ENGINEER's decision at no change in contract price.

Should anything be omitted from the contract drawings or specifications which is necessary to a clear understanding of the work, or should any error appear either in any of the various instruments furnished or in the work done by other contractors affecting the work included under this contract, the Contractor shall promptly notify the ENGINEER of such omission or errors and in the event of the Contractor's failure to do so, he shall make good any damage to or defect in his work caused thereby. He will not be allowed to take advantage of any error or omission on the contract drawings, as full instructions will be furnished by the ENGINEER. Should such error or omission be discovered, the Contractor shall carry out such instructions as if originally specified.

Each and every provision of law and clause required by law to be inserted in this contract shall be deemed to be inserted herein, and this contract shall be read and enforced as though it were included herein, and if through mere mistake or otherwise any such provision is not inserted, or is not correctly inserted, then upon the application of either party hereto, the contract shall forthwith be physically amended to make such insertion.

3. OBLIGATIONS OF CONTRACTOR

The Contractor shall, at his own cost and expense, and in strict conformity with the hereinafter contained or hereto annexed specifications and the contract drawings, furnish all the materials and labor and all tools, implements, machinery and appliances of every kind necessary or proper for the purpose, and in good substantial and workmanlike manner and within the time hereinafter specified, perform and complete the work required under this contract. He shall complete the entire work to the satisfaction and approval of the ENGINEER, and shall accept in consideration thereof, and as full compensation therefor, the sums set opposite the respective classes of work and materials named in the contract and proposal herein contained or hereto annexed, the said sums being the amounts at which the contract therefor was awarded to the Contractor at the public letting thereof.

4. ABSENCE OF CONTRACTOR

In the absence of the Contractor there shall at all times be a duly authorized representative on the work, who shall receive and execute all information provided by the ENGINEER, and such information so given to and received by said representative, shall be deemed to have been given to and received by the Contractor.

5. NOTICES TO CONTRACTOR

The residence or place of business given in the bid or proposal upon which this contract is founded is hereby designated as the place where all notices, letters and other communications shall be served, mailed to or delivered. Any notice, letter or other communication addressed to the Contractor and delivered at the above named place or deposited in a postpaid wrapper in any post office box regularly maintained by the United States Post Office Department shall be deemed sufficient service thereof upon the Contractor, and the date of mailing shall be the date of service. The place named may be changed at any time by an instrument in writing, executed and acknowledged by the Contractor and delivered to the ENGINEER.

Nothing herein contained shall be deemed to preclude or render inoperative the service of any notice, letter or other communication upon the Contractor personally.

6. INSPECTION

The ENGINEER or his authorized representative will inspect the materials furnished and the work done under this contract, and he is also hereby authorized and empowered to reject and refuse all work and materials and the method of application of any part thereof, under or in fulfillment of this contract, that does not comply in kind, quality, quantity, time or place with the specifications and the contract drawings. The inspections, approval or acceptance of any part of the work herein contracted for, or the materials used therein, or any payment on account thereof, shall not prevent the rejection of said work or materials at any time thereafter during the existence of this said work or materials be found to be defective or not in accordance with the requirements of this contract.

7. ENGINEER'S STATUS

The ENGINEER is the agent of the OWNER to the extent provided in the Contract Documents and in special instances he shall, upon request, show the Contractor written authority.

As the ENGINEER is, in the first instance, the interpreter of the conditions of the contract and the judge of its performance, he shall side neither with the OWNER nor with the Contractor, but shall use his powers under the contract to enforce its faithful performance by both.

In case of the termination of the employment of the ENGINEER, the OWNER shall appoint a capable and reputable Engineer against whom the Contractor makes no reasonable objection, whose status under the contract shall be that to the former ENGINEER.

8. ENGINEER'S DECISION

The ENGINEER shall, in all cases, determine the amount, quality, acceptability of the work, materials and equipment which are to be paid for under this contract. He shall also determine all questions in relation to said work and the performance thereof, and decide upon questions which may arise relative to the fulfillment of this contract on the part of the Contractor, except as provided herein. The determinations of the ENGINEER as to work, materials and equipment shall be subject to the final approval of the OWNER.

9. ACCESS TO WORK

The Contractor shall at all times give access to the work to the OWNER, to the ENGINEER and the assistants and inspectors under them, and to representatives of the Department of Health of the State. The Contractor shall furnish all the necessary facilities for determining both on the work and at the places of manufacture, that all work to be done and all materials to be furnished under this contract is being performed and are being made strictly in accordance with the terms of the contract and with the contract drawings and specifications. The Contractor shall notify the ENGINEER in writing at least seven (7) days previous to the commencement of the manufacture of any materials, of the time and place where the manufacture is to take place, in order that a representative of the OWNER may be present to inspect the manufacture, should it be so desired.

10. COMPETENT WORKERS TO BE EMPLOYED

The Contractor shall employ only competent and skillful workers to do the work, and whenever the ENGINEER shall notify the Contractor in writing that any worker on the work is, in their opinion, disorderly, disrespectful, or otherwise unsatisfactory, the Contractor, on receiving such notice, shall forthwith dismiss such person and shall not again employ him for any part of the work without the written consent of the ENGINEER.

11. LAW AND ORDINANCES

The Contractor shall keep himself fully informed of, and shall carefully observe and comply with all State, County and local laws, ordinances and regulations which in any manner affect the conduct of the work, and all such orders or decrees as exist at present and those which may be enacted later, of bodies having any jurisdiction or authority over the work, and shall indemnify and save harmless the OWNER, ENGINEER and all their officers, agents and servants against any claim or liability arising from or based upon the violation of any such law, ordinance, regulation, order or decree, whether by himself or his employees.

12. PERMITS

The Contractor shall take out all necessary permits from the municipal or other public authorities, and shall give all notices required by law or municipal ordinance. Any charge or fee for permits issued by the municipality shall be borne by the OWNER. The OWNER will be reimbursed by the Contractor for the cost of inspection of the work under this contract required by public authorities other than the OWNER, and the municipality, such as the County or the State. The Contractor shall comply with all requirements of the 1964 Assembly Bill No. 803, an act to amend and supplement an act relating to excavation or blasting near pipes distributing or transmitting manufactured, mixed, or natural gas, approved May 12, 1964 (P.L. 1964, C. 53).

13. LABOR-EMPLOYMENT-WAGES-HOURS

The Contractor shall comply with all requirements of the labor laws of the State applicable to contracts on behalf of a municipality for construction, alteration or repair of any building or public work.

14. WORKERS COMPENSATION

The Contractor shall take out and maintain Workers Compensation Insurance to fully protect the OWNER as required by existing law, or as such may be amended during the life of this contract. In case the Contractor shall subcontract any portion of the work, he shall require that all employees of the subcontractor are properly covered by such Workers Compensation Insurance. In case any class of employees engaged in hazardous work under this contract is not protected under Workers Compensation statute, the Contractor shall provide, and shall cause each subcontractor to provide, adequate and suitable insurance for the protection of his employees not otherwise protected.

15. PUBLIC LIABILITY, PROPERTY AND AUTOMOBILE INSURANCE

The Contractor shall take out and maintain during the life of this contract the various types and amounts of insurance as required to protect the Contractor, the OWNER and any subcontractor performing work covered by this contract from claims for damages or personal injury, including accidental death, as well as from claims for property damages which may arise from operations under this contract, whether such operations be by himself or by any subcontractor or by anyone directly employed by either of them.

Pennonni Associates Inc. and its consultants shall specifically be named as additional insured.

## LIABILITY

A. Coverage is to be written on a Commercial General Liability Form providing:

- 1) Premises/Operations Liability Coverage
- 2) Products/Completed Operations Liability Coverage
- 3) Blanket Contractual Liability Coverage
- 4) Broad Form Property Damage Coverage
- 5) Independent Contractors Liability Coverage
- 6) Personal Injury Liability Coverage
- 7) Underground Hazard Liability Coverage
- 8) Explosion and Collapse Hazard Liability Coverage
- 9) Broad Form Comprehensive General Liability Endorsement

(Coverage as required under #7 or #8 shall be waived by the OWNER if the work to be performed by the Contractor on behalf of the OWNER does not necessitate these coverages.)

B. The Liability Policy must be written with a minimum combined single limit of \$1,000,000 for Bodily Injury and Property Damage.

## AUTOMOBILE LIABILITY

A. The coverage is to be written on a Commercial Automobile Liability form providing liability coverage for all owned, hired and non-owned automobiles.

B. The Automobile Liability Policy must be written with a minimum combined single limit of \$1,000,000 for Bodily Injury and Property Damage.

## WORKER'S COMPENSATION AND EMPLOYER'S LIABILITY

A. The Worker's Compensation Policy must be issued to provide statutory coverage for the State of New Jersey.

## EXCESS LIABILITY/UMBRELLA

A. Umbrella Liability coverage is to be provided with a minimum limit of \$1,000,000 in excess of all underlying primary coverages required by the OWNER.

## OWNER'S, CONTRACTOR'S PROTECTIVE LIABILITY

A. An Owner's, Contractor's Protective Liability Policy with a \$2,000,000 Limit of Liability must be provided in the name of the OWNER of the project.

## BUILDER'S RISK

- A. Builder's Risk coverage will be provided on an "All Risk Basis" subject to standard policy conditions and exclusions for the total value of the amount shown within the bid for any structure or building that will become real property upon completion of the contract. Otherwise this coverage will not be required.

## FILING OF CERTIFICATES, ENDORSEMENTS AND POLICIES

- A. Certificates in triplicate from the insurance carrier stating the limits of liability and expiration date shall be filed with the OWNER before operations are begun. Such certificates shall not merely name the types of policy provided, but shall specifically refer to this Contract and shall contain a separate express statement of compliance with each of the requirements as set forth in the section.
- B. All policies as hereinafter required shall be so written that the OWNER and additional insured will be notified of cancellation or restrictive amendment at least thirty (30) days prior to the effective date of such cancellation of amendment.
- C. If any part of the work is sublet, insurance of the same types and limits as required by above items shall be provided by or on behalf of the subcontractor to cover that part of the work that they have contracted to perform.
- D. The policies of insurance so required to be purchased and maintained shall include as additional insured OWNER, ENGINEER, ENGINEER'S Consultants and any other persons or identities named in the supplementary conditions and shall include coverage for their respective officers and employees.

## 16. SOCIAL SECURITY ACT

The Contractor shall be and remain an independent contractor with respect to all services performed hereunder and agrees to and does hereby accept full liability for the payment of any and all contributions or taxes for social security, unemployment insurance, federal withholding tax or old age retirement benefits, pensions or annuities, nor or hereafter imposed under any state or federal law which are measured by the wages, salaries, or other remuneration paid to persons employed by the Contractor on work performed under the terms of this contract, and further agrees to obey all lawful rules and regulations and to meet all lawful requirements which are now or hereafter may be issued or promulgated under said respective laws by any duly authorized state or federal officials; and said Contractor also agrees to indemnify and save harmless the OWNER from any such contributions or taxes or liability thereof.

## 17. ASSIGNMENT OF CONTRACT

The contractor or his thoroughly qualified and designated representative shall give his personal attention constantly to the faithful prosecution of the work. He shall not assign, transfer, convey or otherwise dispose of this contract, or his right, title, or interest in, or to the same or any part thereof, without the previous approval of the OWNER.

The Contractor shall not assign, by power of attorney or otherwise, any of the monies to become due and payable under this contract, unless by and with the written consent of the OWNER, and such consent or approval, if given, will not relieve the Contractor from any of the obligations of said contract.

Assignment of this contract or any part thereof or of any funds to be received thereunder by the Contractor shall contain a clause to the effect that it is agreed that the funds to be paid the assignee under the assignment are subject to a prior lien for services rendered or materials supplied for the performance of the work called for in said contract in favor of all persons, firms or corporations rendering such services or supplying such materials.

18. ROYALTIES AND PATENTS

The Contractor shall indemnify and save harmless the OWNER and its officers and agents from all damages, judgements, claims and expenses arising from the infringement of any letters, patent, or patent right because of any royalty, fee or license for the use, arrangement or operation of any tools, machinery, appliances, devices, materials, process or processes which may be used by the Contractor or furnished by him in fulfillment of the requirements of this contract. In the event of any claim or action at law on account of such patent or fees, it is agreed that the OWNER may retain out of the monies which are, or which may become due the Contractor under his contract, a sum of money sufficient to protect itself against loss, and to retain the same until said claims are paid or satisfactorily adjusted.

19. CLAIMS FOR LABOR, MATERIALS AND DAMAGES

The Contractor shall, from time to time, as required by the OWNER, furnish the OWNER with satisfactory evidence that all persons who have done work or furnished materials under this contract, or have suffered some damage on account of the Contractor's operations, have been fully paid or secured; and in case such evidence be not furnished as aforesaid, such amount as the OWNER may consider necessary to meet the lawful claims of the persons aforesaid will be retained from the monies otherwise due said Contractor, until the liabilities aforesaid have been fully satisfied. It is understood and agreed, however, that the OWNER hereby assumes no obligation toward such claimants, nor in any way undertakes to pay such claims out of any funds due or that may become due the Contractor, or out of its own funds.

20. ACCIDENTS AND CLAIMS TO BE GUARDED AGAINST

All machinery and other physical hazards shall be guarded in accordance with safety codes approved by the American Standard Association, unless such codes are not compatible with Federal, State or Municipal Laws or Regulations.

The Contractor, when necessary, shall erect and maintain on the work such strong and suitable barriers and at nighttime such red lights as will efficiently and effectually prevent any accident to life, limb or property on consequence of said work, or in the use or occupancy of street, alley, highway or public or private grounds.

The status of the Contractor in the work to be performed by him under the contract is that of an independent contractor. As such, the work, in every respect, from the execution of the contract and during progress of the work thereunder, and until final acceptance, shall be under



the charge and in care of the Contractor and at his risk. He shall properly safeguard against any or all injury to the public, to public and private property, materials and things and, as such, the Contractor alone shall be responsible for any and all damage, loss or injury to persons or property that may arise, or be incurred in, or during the conduct or progress of said work without regard to whether the Contractor, his subcontractors, agents or employees, have been negligent. The Contractor shall keep the OWNER and ENGINEER free from and discharged of any and all responsibility and liability therefor of any sort or kind whatsoever. The Contractor shall assume all responsibility for risks and casualties of every description and for any or all damage, loss or injury to persons or property arising out of the nature of the work from the action of the elements, or from any unforeseen or unusual difficulty or circumstance.

Contractor shall be responsible for initiating, maintaining and supervising all safety precautions and programs in connection with the work. Contractor shall take all necessary precautions for the safety of, and shall provide the necessary protection to prevent damage, injury or loss to, all persons, work materials, equipment and property at the site or adjacent thereto.

Contractor shall designate a safety representative at the site whose responsibilities shall be safety precautions and the prevention of accidents.

The Contractor shall assume and be liable for all blame and loss of whatsoever nature by reason of neglect or violation of any Federal, State, County or local laws, statutes, ordinances or any and all rules and regulations promulgated thereunder. The Contractor shall indemnify and save harmless the OWNER and ENGINEER and all of their respective officers, agents and employees from all liability or suits or actions at loss or in equity of any kind whatsoever arising from the failure of the Contractor to comply with the terms and conditions of the contract, plans and specifications or any Federal or State statutes or local ordinances or any rules and regulations promulgated, in accordance with the provisions of such statutes or ordinances by the United States, the State of New Jersey, or any municipality thereof, or by any department or agency of any or all thereof, and the Contractor shall, if required by the OWNER or ENGINEER, produce evidence of settlement of any such action before final payment under the contract shall be made by the OWNER.

The Contractor shall, unless otherwise specified, maintain and pay for such insurance, issued in the name of the OWNER, as will protect the OWNER from contingent liability under this contract, and the OWNER's right to enforce against the Contractor any provision of this article shall be contingent upon the full compliance by the OWNER with the terms of such insurance policy or policies, a copy of which shall be deposited with the OWNER.

## 21. STATEMENT OF QUANTITIES

The quantities of the work to be done and the materials to be furnished under this contract as given in the Instructions to Bidders or attached hereto or as indicated on the Specifications, are to be used solely as a uniform basis for comparing proposals and/or for determining the amount of the Contractor's performance bond. The OWNER shall not be held responsible if any of the said quantities are found incorrect or omitted and the Contractor shall not make any claim for damages or for loss of profits or for an extension of time because of a difference between the quantities of the various classes or work as estimated and the

work actually performed. If any error, omission, or misstatement is discovered in the said estimated quantities, the same shall not invalidate the contract or release the Contractor from execution and completion of the whole or any part of the work to the satisfaction of the ENGINEER and in accordance with the specifications and plans and for the prices agreed upon and fixed therefor or excuse him from any of the obligations or liabilities set forth in the Contract Documents, or entitle him to any damages or compensation otherwise than is specified in said Contract Documents. The quantities of the various work on which payments will be made to the Contractor are to be determined by measurements of the work actually performed by the Contractor and accepted by the ENGINEER as being satisfactorily completed in accordance with the requirements of the Contract Documents.

Before submitting this proposal, the Contractor shall determine for himself the quantities of work required and the conditions under which the work will be performed, by such means as he may prefer, and shall assume all risks as to variations in the quantities of the different classes of work.

He shall not at any time after the submission of this proposal, dispute or complain of the schedule of quantities or assert that there was any misunderstanding as to the amount or character of the work to be done, and shall not make any claim for damages, or for loss of profits, or for an extension of time because of a difference between the quantities of the various classes of work stated, and the quantities of work actually performed.

## 22. MATERIALS AND WORK

All materials furnished under this contract shall be as specified or required, or in the absence of particular specification shall be the best of their respective kinds, or new stock, unused and not deteriorated and all the work contemplated and described shall be done in a good, substantial and workmanlike manner. Only manufactured products of the United States, wherever available, shall be incorporated into the work of the contract.

Wherever in these specifications or on the plans, the terms ASTM, AWWA, ASA and SAE specifications are used, it shall be considered to mean the latest pertinent specifications (Standard or Tentative) of the American Society for Testing Materials, American Water Works Association, American Standard Association, and the Society of Automotive Engineers respectively, and any subsequent amendments thereto.

Wherever in the contract drawings or specifications any item of equipment or material is designated by reference to a particular brand name, manufacturer or trade name, it shall be understood that an approved equal product, acceptable to the ENGINEER, may be substituted by the bidder. The Contractor will be required to demonstrate to the satisfaction of the ENGINEER that the equipment, devices or materials he proposes to furnish are, in fact, similar or equal to those designated.

23. DEFECTIVE WORK OR MATERIALS

If at any time before the final acceptance of the work, any materials or workmanship shall be discovered, which do not comply with the specifications and contract drawings, they shall be immediately removed by the Contractor, when notified to do so by a written notice from the ENGINEER, and shall be replaced at the Contractor's expense. Any work condemned by the ENGINEER as unsuitable or improperly done shall be removed and repaired, or otherwise remedied, as requested by the ENGINEER.

All material condemned by the ENGINEER shall be removed from the site of the work within two (2) days if and after notice to that effect is given.

Should defective work be suspected and the ENGINEER so requires, the Contractor shall uncover, take down or make openings in the finished work for the purpose of examining at such points as said ENGINEER designates. Should the work thus exposed or examined prove satisfactory, the uncovering, taking down or making openings in and the replacing of the covering or the making good of the parts removed shall be paid for in accordance with the contract prices for the items involved; but should the work exposed or examined prove unsatisfactory, the uncovering, taking down and replacing and making good shall be at the expense of the Contractor.

If the Contractor shall neglect or refuse to remove or replace the same within seven (7) days from the date of the written notice from the ENGINEER to do so, said notice being served either personally or by leaving it at his place of business or with his agent in charge of the work, then the OWNER may remove or cause the same to be removed and satisfactorily replaced by contract or otherwise, as he may deem expedient, and charge the expense thereof to the Contractor. The expense so charged will be deducted and paid by the OWNER out of such monies as are or may become due under this Agreement; or if such monies are not sufficient to meet the said expense, the additional monies shall be furnished by the Contractor; and if he refuses or neglects to provide the necessary monies, they shall be provided by his surety.

24. PERMISSIBLE CHANGES AND VARIATIONS IN THE WORK

Should it be deemed necessary in the execution of the work, by reason of any condition or circumstance arising or discovered after the making of the contract, to make any minor variation desirable or necessary for the stability, economy or betterment of the work, which variations increase or decrease the quantities of the work specified or change the location thereof to an extent not unreasonably affecting the conditions of the work, and further interpreted by the ENGINEER as involving no classes of work other than those called for by this contract, the Contractor shall, upon written order from the ENGINEER to that effect, make such minor variations. If such minor variations diminish the quantity of the work to be done, no claim for damages or for anticipated profits on the work that may be dispensed with shall thereby accrue to the Contractor, and the value of the work dispensed with will not be included in any payments made to the Contractor. If such minor variations increase the amount of the work, the value of such increase shall be determined and fixed by the ENGINEER in accordance with the quantity of such work actually done, and/or at the unit prices stipulated in the contract.

Such alterations or changes as are mentioned in this section shall not vitiate or annul the obligations of the contract or the agreement of the work.

25. EXTRA WORK

Any extra work not originally contemplated under this contract and not covered by unit or lump sum prices in the proposal shall be performed by the Contractor if ordered in writing by the ENGINEER. Such extra work shall be subject to payment under the contract with a subsidiary agreement or a change order fixing the prices and method of payment and of doing the work or shall be compensated on the basis of reasonable cost of necessary labor and materials and an allowance of fifteen percent for overhead and profit as may be stipulated by the OWNER in the written authorization for the work.

A formal subsidiary agreement will be prepared for execution by the OWNER and Contractor in all cases of extra work involving major changes in or additions to the project. A change order in letter form addressed to the Contractor by the ENGINEER and containing approved endorsements of the OWNER and Contractor will be prepared in all cases of extra work involving major changes in or additions to the project. At the discretion of the OWNER, extra work may be ordered on a labor, materials, overhead and profit basis as set forth above.

In cases where extra work is ordered on a labor, materials, overhead and profit basis, the cost may include all items of labor or materials, the use of power tools and equipment actually used, power and all items of cost such as public liability and workmen's compensation insurance, pro rata charges for foreman, also social security, old age and unemployment insurance; however, no percentage for overhead and profit shall be allowed on items of social security, old age and unemployment insurance. If deductions are ordered, the credits shall be the net costs. Among the items considered as overhead are included insurance other than mentioned above, bond or bonds, superintendent, timekeeper, clerks, watchmen, use of small tools, incidental job burdens, and general office expense. Charges for equipment shall be based upon the latest rental rates published by the Associates Equipment Distributors, Chicago, Illinois.

The Contractor shall give the ENGINEER access to all accounts, bills, payrolls and vouchers relating to such extra work and he agrees that he shall have no claim for compensation for such extra work in the case of items not covered by unit prices unless a statement in writing of the actual cost of the same, fully itemized as to labor, materials and other allowable costs is presented to the ENGINEER before the fifteenth day of the month following that during which each specific order was complied with by him.

26. OTHER CONTRACTS

It is understood and agreed that the Contractor shall execute his work in such a manner and in such order as will not interfere with work in progress and will permit the OWNER to perform other work or to enter into other contracts for work and materials to be constructed or placed in, on, or about the work herein described, with the least interference possible and with complete cooperation whenever it is desirable to prosecute said work, either simultaneously with the work under this contract or otherwise. It is agreed that the Contractor shall not be entitled to any damages or extra compensation from the OWNER on account of any work performed by the OWNER or other contractors that in any way affects the work under this

contract, provided that such work of the OWNER and other contractors shall, in the opinion of the ENGINEER, be performed in a proper and expeditious or a necessary manner. The ENGINEER shall decide all questions between the Contractor hereunder, the other contractors, and the order of carrying on the work shall always be subject to their approval.

If, in the judgement of the ENGINEER, the joint occupation of the site of the work by the OWNER, or by two or more contractors working on different contracts at the same time actually impedes progress on the work herein described, then upon the recommendation of the ENGINEER, the OWNER may extend the time for the completion of the work by a length of time which accords with and compensates for the delay so caused. In case the Contractor by his own acts, or the acts of any person or persons in his employ, shall unnecessarily delay, in the opinion of the ENGINEER, the work of the OWNER or other contractors by not allowing them sufficient opportunity or facility to perform work as may be specified, the Contractor shall, in that case, pay all costs and expenses incurred by such parties due to any such delays, and he hereby authorizes the OWNER to deduct the amount of such cost and expenses from any monies due or to become due the Contractor under this contract. The ENGINEER, subject to the approval of the OWNER, shall decide the extent of such delay or delays, and the amount of such cost and expenses, and their decision shall be binding upon both parties to this contract. Nothing contained in this paragraph shall, however, relieve said Contractor from any liability or damage resulting to the OWNER on account of such delay or delays.

If any part of the Contractor's work depends for proper execution or results upon the work of any other contractor, the Contractor shall inspect and promptly report to the ENGINEER any defects in such work that render it unsuitable for such proper execution and results. His failure to so inspect and report shall constitute an acceptance of the other contractor's work as fit and proper for the reception of his work, except as to defects which may develop in the other contractor's work after the execution of his work.

To insure the proper execution of this subsequent work, the Contractor shall measure work already in place and shall at once report to the ENGINEER any discrepancy between the executed work and the drawings.

27. SUSPENSION OF WORK

The OWNER shall have the right to suspend the whole or any part of the work to be done hereunder, when, in the opinion of the OWNER, the Contractor is not doing the work in accordance with the provisions of the contract and specifications.

28. REMEDIES

All claims, counterclaims, disputes and other matters in question between the OWNER and the Contractor arising out of or relating to this Agreement or the breach thereof will be decided by arbitration if the parties hereto mutually agree, or in a court of competent jurisdiction within the State in which the OWNER is located.

29. ABANDONMENT OF WORK

Should the Contractor abandon or in any manner fail to complete the said work, the OWNER is hereby authorized and empowered to pay any laborers for work done who may have been

employed by said Contractor upon the work herein, and to pay any claims against the Contractor for material furnished, out of any funds that would otherwise be due or become due said Contractor under this contract, and in every such case the said OWNER is hereby authorized and empowered to ascertain through the ENGINEER, the amount or amounts so due or owing to such labor or laborers, or for material, from said Contractor, in such manner and upon such proof as the said ENGINEER may deem sufficient; and the amount or amounts so found by the ENGINEER to be due and payable be final and conclusive against the Contractor, and may therefore be paid by the OWNER to said labor or laborer, or to liquidate claims for materials furnished; and any estimate may be withheld from said Contractor until all such claims for labor or material on his contract have been satisfied.

30. FORFEITURE OF CONTRACT

The OWNER at any time during the continuance of the contract for the work herein provided for, and prior to the date of the acceptance of the work as hereinafter provided, shall have the right and power to declare the whole or any part of the same forfeited for the violation of any of the conditions, terms, requirements or limitations herein contained, if the performance of the contract is unnecessarily or unreasonably delayed, or if the Contractor is not progressing with the work as fast as is necessary to insure its completion within the time specified by this contract, or if the Contractor is showing bad faith in carrying out the contract, or if the work be not fully completed within the time fixed in this contract, for its completion, or within the time to which such completion may be extended as hereinafter provided, or further, if the Contractor shall fail or refuse to remedy or repair defective work or materials when so ordered as herein provided. If the OWNER shall declare the said contract forfeited, in whole or in any particular, such declaration of forfeiture shall in no way relieve or affect the liability of the Contractor and his sureties for breach of any of the covenants and conditions of said contract.

The OWNER will give written notice of the Contractor stating the effective date of the forfeiture. This notice will be delivered to the Contractor at least five (5) days before said effective date.

On such event, all finished or unfinished documents, data, studies, surveys, drawings, maps, models, photographs and reports prepared by the Contractor under this Contract shall, at the option of the OWNER, become the OWNER's property and the Contractor shall be entitled to receive just and equitable compensation for any work satisfactorily completed hereunder.

Notwithstanding the above, the Contractor shall not be relieved of liability to the OWNER for damages sustained by the OWNER by virtue of any breach of the Contract by the Contractor, and the OWNER may withhold any payments due the Contractor until such time as the exact amount of damages due the OWNER from the Contractor is determined.

31. COMPLETION OF CONTRACT BY OWNER

If the work to be done hereunder shall be abandoned by the Contractor, or, if this contract shall be assigned or the work sublet by him, otherwise than as herein specified, or if at any time and for reasons hereinbefore specified, the OWNER declares the contract forfeited, the OWNER may notify the Contractor to discontinue all work or any part thereof, hereunder, or may notify the said Contractor to remedy or correct the condition or breaches enumerated by a written notice served upon the Contractor. In the event that the work is ordered discontinued

as herein provided, or in case the said conditions or breaches are not remedied and corrected to the satisfaction of the OWNER within seven (7) days from the service of the said written notice, the OWNER will thereupon have the power to contract for the completion of the work, or such parts thereof, in the manner prescribed by law, or to employ such and so many persons as he may deem advisable, by contract or otherwise to work at and complete the work herein described or such parts thereof, and to use such machinery, materials, tools and appliances as may be found upon the site of the work, and to produce other materials, machinery, tools and appliances for the completion of the same, and to charge the expense so incurred to the Contractor. The expense so charged will be deducted and paid by the OWNER out of such monies as may be due or may at any time thereafter become due to the Contractor under and by virtue of this contract or any part thereof. In case such expense exceeds the amount due and payable or which would become due and payable under this contract, if completed by the Contractor, the amount of such excess shall be repaid to the OWNER and in case such expense shall be less than the sum which would have been payable under this contract, if the same had been completed by the Contractor, then the Contractor shall be entitled to receive the difference. When any particular part of the work is being carried on by the OWNER, by contract or otherwise, under the provisions of this clause of the contract, the Contractor shall continue the remainder of the work in conformity with the terms of this contract, and in such manner as will in nowise hinder or interfere with the persons or workers employed, as above provided, by the OWNER, by contract or otherwise, to do any part of the work or to complete the same under the provisions of this article of the contract.

32. COMPLETION OF WORK DEFINED

The completion of the herein specified work is defined as that stated when the installations and the appurtenant equipment included under this contract have been completed and tested, and are together, ready for continuous permanent use and occupancy for the purpose intended. After this date, there may still remain some cleaning up or other minor work, which does not prevent the permanent use of the contracted work.

33. TIME FOR COMPLETION

Work on this contract shall be commenced within ten (10) days from the date a notice from the OWNER/ENGINEER is received to commence work.

The work shall be carried on with such force and in such manner and order and at such points that by the date stipulated in the proposal and contract, or as may be modified or extended as hereinafter provided, the whole work and its parts shall be performed in accordance with the terms of this contract.

It is mutually agreed and understood by and between the parties hereto that time is an essential part of this contract, and that, if the Contractor shall fail to complete the work or any part thereof within the time above fixed, the OWNER may retain as liquidated damages as a result of such delay, from monies that are or which may become due the said Contractor, such sum per day as specified in the contract for each and every day (Sundays and legal holidays excepted) the completion of the work be delayed beyond the time specified herein for such completion.

It is understood and agreed that by the signing of the foregoing contract the Contractor waives any legal defense he might have because of the omission of a bonus clause in the event of completion before the date agreed upon, the term "Liquidated Damages" governing absolutely.

It is agreed by and between the parties hereto that inasmuch as expenses and inconvenience and other damages will be sustained by the OWNER in the event that said Contractor fails to perform the work herein specified within the time herein set forth, such as inconvenience of the public, consulting and field engineering expenses, interest charges, wages, salaries of inspectors, delay caused to other work by failure to perform this contract, and other elements, some of which are indefinite and in some cases insusceptible of easy proof, the sum per day specified in the contract for each day's delay (Sundays and legal holidays excepted) shall be considered as liquidated damages and not as a penalty and shall become due said OWNER as full payment for all such expenses and damages sustained to fit by the failure of said Contractor to complete the work as herein specified.

34. DELAYS AND EXTENSION OF TIME FOR COMPLETION

- a. The OWNER shall have the right to defer the beginning or to suspend the whole or any part of the work herein contracted to be done whenever, in the opinion of the OWNER or ENGINEER, it is necessary or expedient for the OWNER to do so. If the Contractor is delayed in the completion of the work by such deferral or suspension or by strikes, lockouts, fire, delay of common carriers, unavoidable casualties, delays caused by other contractors, subcontractors or suppliers or for any other reason outside of the control of the OWNER, then for all such delays and suspensions, the Contractor shall be allowed one day additional to the time herein stated for each and every day of such delay so caused in the completion of the work, the same to be determined by the ENGINEER. No such extension shall be made for any of such delays unless within ten days after the beginning of such delay, a written request for additional time is filed by the Contractor with the ENGINEER. In case of a continuing cause of delay, only one request shall be necessary.
- b. Nothing herein shall limit the Contractor's remedy for the OWNER's negligence, bad faith, active interference, tortious conduct or other reasons un contemplated by the parties that delay the Contractor's performance, to giving the Contractor an extension of time for performance under this contract. In such cases, the Contractor may claim as additional compensation only the amount of any additional out-of-pocket expenses actually incurred as a result of such action by the OWNER. No claim for such damages shall be given unless within ten days after the beginning of such delay, a written request for additional compensation shall be filed with the ENGINEER. In case of a continuing cause of delay, only one request shall be necessary. The Contractor shall provide the OWNER and the ENGINEER with such documentation as may be requested to verify the claim for reimbursement of actual additional out-of-pocket expenses.

35. PRICES

The OWNER will pay and the Contractor shall receive the prices stipulated in the proposal herein contained or hereto annexed, as full compensation for furnishing all the materials and performing all the labor which may be required in the prosecution and completion of the work in the contract as described and specified, and as shown on the contract drawings, and also for



all loss and damages arising out of the nature of the work aforesaid, or from the action of the elements or from any unforeseen obstruction or difficulty encountered in the prosecution of work, and for all expense incurred by or in consequence of the suspension or discontinuance of the work as herein specified.

36. APPROVAL AND ACCEPTANCE OF WORK

Following the completion of this contract, as such completion is defined herein, and as soon thereafter as practicable, the OWNER will inspect the entire work on all parts and details or cause the same to be inspected, and if said work and all contract performances are found to be satisfactory and in accordance with the provisions and terms of the contract and specifications, the OWNER will certify the work as completed and will accept it, but conditional upon the subsequent remedying of defects which may become manifest within a period of one year following completion and as herein required. The certification of completion and the said acceptance of the work will be prerequisite to final payment hereunder.

37. ESTIMATES AND PAYMENT - PARTIAL AND FINAL

The ENGINEER will, each month, make an approximate partial estimate, such as he shall believe to be just and fair, of the amount and value of the work done and the materials incorporated into the work during the previous calendar month, whenever said monthly work exceeds One Thousand Dollars (\$1,000.00) in value. More frequent estimates may, at the option of the OWNER, be made at any time during the progress of the work, and payment may at any time be withheld if the work is not proceeding in accordance with the contract.

Upon such estimate being made and certified by the ENGINEER and approved by the OWNER, the OWNER will pay to the Contractor ninety percent (90%) of the amount stated in such estimate or certificate to be the value of the work therein certified to have been done, except that when the total contract price exceeds One Hundred Thousand Dollars (\$100,000.00), then the OWNER will pay to the Contractor ninety eight percent (98%) of the amount stated on said estimate or certificate. In lieu of the two percent (2%) cash retainage on contracts exceeding \$100,000.00, the Contractor may agree to deposit negotiable bearer bonds of the State of New Jersey, or negotiable bearer bonds or notes of any political subdivision of the State, the value of which is equal to two percent (2%) of said estimate or certificate, provided they are delivered directly to and approved by the OWNER. The value of a bond or note shall mean par value or current market value, whichever is lower. The OWNER may at all times reserve and retain out of any or all of said partial payments, all such sums as it is or may be authorized to reserve or retain.

The making of any such estimates or payment thereon shall not be taken or construed as an approval or acceptance by the OWNER of any work so estimated. Allowances will be made for all materials placed along or upon the site, or stored at secured locations, which are suitable for use in the execution of the contract, if the person providing the materials furnishes releases of liens for the materials at the time each estimate of work is submitted for payment. The total of all the partial payments shall not exceed ninety percent (90%) of the cost of the materials. The cost of such materials shall be verified by vouchers from the materials' suppliers.

Following the completion of the work and the acceptance thereof as previously defined, the Contractor shall file with the OWNER his Contractor's Certificate duly executed. As soon after as practicable, the ENGINEER will make a final estimate of the amount of work done by the

Contractor and of the value thereof. Upon such estimate being made and certified by the ENGINEER and approved by the OWNER, the OWNER will return to the Contractor any bonds or notes deposited and any interest accruing on such bonds or notes, and will pay the Contractor the full value of the work done under this contract. Any interest accruing on cash payments withheld shall be credited to the OWNER.

38. LIENS

The final payment shall not become due until the Contractor, if required, shall deliver to the OWNER a complete release of all liens arising out of this contract, or receipts in full in lieu thereof and, if required, an affidavit that so far as he has knowledge or information the release and receipts include all the labor and material for which a lien could be filed; but the Contractor may, if any subcontractor refuses to furnish a bond satisfactory to the OWNER to indemnify him against any lien. If any lien remains unsatisfied after all payments are made, the Contractor shall refund to the OWNER all monies that the later may be compelled to pay in discharging such a lien, including all costs and a reasonable attorney's fee.

39. CONTRACTOR'S CLAIM FOR DAMAGES

If the Contractor shall claim compensation for any damage sustained by reason of the acts of the OWNER, or its agents, he shall, within seven (7) days after the sustaining of such damage, make a written statement to the ENGINEER of the nature of the damage sustained. On or before the fifteenth day of the month subsequent to that in which any such damage shall have been sustained, the Contractor shall file with the ENGINEER an itemized statement of the details and the amount of such damage, and unless such statement is made as thus required, his claim for compensation shall be forfeited and invalidated, and he shall not be entitled to payment on account of any such damage.

40. NO WAIVER OF CONTRACT

Neither an extension of time for any reason beyond the date fixed herein for the completion of the contract, nor the delivery and acceptance of any articles or materials, nor any payment for, nor acceptance of the whole or any part of the work by the ENGINEER, nor any possession taken by the OWNER, or its employees or agents, shall be deemed to be a waiver by the OWNER of the right to abrogate this contract for abandonment or delay or non-performance in the manner herein provided, nor shall it operate to void or annul any of the terms of this contract.

41. NO ESTOPPEL

Neither the OWNER nor any department or officer thereof, shall be precluded or estopped by any return or certificate made or given to the OWNER, the ENGINEER, or other officer, agent or appointee to the OWNER under any provision of this agreement, from any time before the completion and acceptance of the work, and payment therefore, or before the payment of the guarantee retainer, pursuant to any such return or certificate showing the true and correct amount and character of the work done and materials furnished by the Contractor or any other person under this agreement, or that any such return or certificate is untrue and incorrect or improperly made in any particular, or that the work and materials, or any part thereof, do not in fact conform to the specifications and contract drawings, and the OWNER shall not be precluded or estopped, notwithstanding any such return or certificate any payment in

accordance therewith, from demanding and recovering from the Contractor such damages as it may sustain by reason of his failure to comply with the specifications and contract drawings.

42. SUBLETTING

The Contractor must perform, construct or install not less than 50% of each contract with his own forces and equipment. Only special items approved by the ENGINEER may be sublet.

The Contractor shall not sublet any part of the work included in this contract without the previous approval of the ENGINEER. In making application for subletting any portion of the work, the Contractor shall state in writing, the portion of the work which each subcontractor is to do or the material which he is to furnish, his place of business, and such other information as may be required in order to ascertain whether such subcontractor is responsible, reliable and able to perform the work or to furnish the materials as called for in the specifications.

Subletting, if permitted, shall not relieve the Contractor of any of his obligations under this contract. The Contractor shall be as fully responsible to the OWNER for the acts and omissions of his subcontractors, and of persons either directly or indirectly employed by them as he is for the acts and omissions of persons directly employed by him.

The Contractor shall cause appropriate provisions to be inserted in all subcontracts relative to the work, to bind subcontractors to the Contractor by the terms of the General Conditions and other Contract Documents insofar as applicable to the work of subcontractors, and to give the Contractor the same power as regards terminating any subcontract that the OWNER may exercise over the Contractor under any provisions of the Contract Documents.

Nothing contained in this contract shall create any contractual relations between any subcontractor and the OWNER.

Within five days after the Contractor receives payment for work performed under this contract, he shall pay each subcontractor for the amount allowed the Contractor for and on account of work performed by the subcontractor to the extent of the subcontractor's interest therein.

43. RELATIONS OF CONTRACTOR AND SUBCONTRACTOR

The Contractor agrees to bind every subcontractor and every subcontractor agrees to be bound by the terms of the Agreement, the General Conditions, the Drawings and Specifications as far as applicable to his work, including the following provisions of this article, unless specifically noted to the contrary in a subcontract approved in writing as adequate by the OWNER or ENGINEER.

This does not apply to minor subcontracts.

The subcontractor agrees:

- a. To be bound to the Contractor by the terms of the Agreement, General Conditions, Drawings and Specifications, and to assume toward him the obligations and responsibilities that he, by those documents, assumes toward the OWNER.

- b. To submit to the Contractor applications for payment in such reasonable time as to enable the Contractor to apply for payment.
- c. To make all claims for extras, for extensions of time and for damages for delays or otherwise, to the Contractor in the manner provided in the General Conditions for like claims by the Contractor upon the OWNER, except that the time for making claims for extra cost is one week.

The Contractor agrees:

- a. To be bound to the subcontractor by all the obligations that the OWNER assumes to the Contractor under the Agreement, General Conditions, Drawings and Specifications, and by all the provisions thereof affording remedies and redress to the Contractor from the OWNER.
- b. To pay the subcontractor, upon the payment of certificates, if issued under the schedule of values described herein, the amount allowed to the Contractor on account of the subcontractor's work to the extent of the subcontractor's interest therein.
- c. To pay the subcontractor, upon the payment of certificates, if issued otherwise than in "b" so that at all times his total payments shall be as large in proportion to the value of the work done by him as the total amount certified to the Contractor is to the value of the work done by him.
- d. To pay the subcontractor to such extent as may be provided by the Contract Documents or the subcontract, if either of these provides for earlier or larger payments than the above.
- e. To pay the subcontractor on demand for his work or materials as far as executed and fixed in place, less the retained percentage, at the time the certificate should be issued, even though the ENGINEER fails to issue it for any cause not the fault of the subcontractor.
- f. To pay the subcontractor a just share of any fire insurance money received by him, the Contractor.
- g. To make no demand for liquidated damages or penalty for delay in any sum in excess of such amount as may be specifically named in the subcontract.
- h. That no claim for services rendered or materials furnished by the Contractor or to the subcontractor shall be valid unless written notice thereof is given by the Contractor to the subcontractor during the first ten (10) days of the calendar month following that in which the claim originated.
- i. To give the subcontractor an opportunity to be present and to submit evidence in any arbitration or court action involving his rights.
- j. If arbitration is used, name as arbitrator under arbitration proceedings as provided in the General Conditions, the person nominated by the subcontractor, if the sole cause of dispute is the work, materials, rights or responsibilities of the subcontractor; or if of the subcontractor and other subcontractors jointly, to name as such arbitrator the person upon whom they agree.
- k. In the matter of arbitration or court action, their rights and obligations and all procedures shall

be analogous to those set forth in this contract.

Nothing in this paragraph shall create any obligation on the part of the OWNER to pay or see to the payment of any sums to any subcontractor.

44. WAGE RATES

Not applicable.

45. MANDATORY EQUAL EMPLOYMENT OPPORTUNITY LANGUAGE  
N.J.S.A. 10:53-1 et seq., N.J.A.C. 17:27

During the performance of this contract, the contractor agrees as follows:

- a. The contractor or subcontractor, where applicable, will not discriminate against any employee or applicant for employment because of age, race, creed, color, national origin, ancestry, marital status, affectional or sexual orientation or sex. Except with respect to affectional or sexual orientation, the contractor will take affirmative action to ensure that such applicants are recruited and employed, and that employees are treated during employment, without regard to their age, race, creed, color, national origin, ancestry, marital status, affectional or sexual orientation or sex. Such action shall include, but not be limited to the following: employment, upgrading, demotion, or transfer; recruitment or recruitment advertising; layoff or termination; rates of pay or other forms of compensation; and selection for training, including apprenticeship. The contractor agrees to post in conspicuous places, available to employees and applicants for employment, notices to be provided by the Public Agency Compliance Officer setting forth provisions of this nondiscrimination clause.
- b. The contractor or subcontractor, where applicable will, in all solicitations or advertisements for employees placed by or on behalf of the contractor, state that all qualified applicants will receive consideration for employment without regard to age, race, creed, color, national origin, ancestry, marital status, affectional or sexual orientation or sex.
- c. The contractor or subcontractor, where applicable, will send to each labor union or representative of workers with which it has a collective bargaining agreement or other contract or understanding, a notice, to be provided by the agency contracting officer advising the labor union or workers' representative of the contractor's commitments under this act and shall post copies of the notice in conspicuous places available to employees and applicants for employment.
- d. The contractor or subcontractor where applicable, agrees to comply with any regulations promulgated by the Treasurer pursuant to **N.J.S.A. 10:5-31 et seq.**, as amended and supplemented from time to time and the Americans with Disabilities Act.

- e. When hiring or scheduling workers in each construction trade, the contractor or subcontractor agrees to make good faith efforts to employ minority and women workers in each construction trade consistent with the applicable employment goal prescribed by **N.J.A.C. 17:27-7.3**; provided, however, that the Division may, in its discretion, exempt a contractor or subcontractor from compliance with the good faith procedures prescribed by the following provisions, 1, 2 and 3, as long as the Division is satisfied that the contractor or subcontractor is employing workers provided by a union which provides evidence, in accordance with standards prescribed by the Division, that its percentage of active “card carrying” members who are minority and women workers is equal to or greater than the applicable employment goal established in accordance with **N.J.A.C. 17:27-7.3**.

The contractor or subcontractor agrees that a good faith effort shall include compliance with the following procedures:

- (1) If the contractor or subcontractor has a referral agreement or arrangement with a union for a construction trade, the contractor or subcontractor shall, within three business days of the contract award, seek assurances from the union that it will cooperate with the contractor or subcontractor as it fulfills its affirmative action obligations under this contract and in accordance with the rules promulgated by the Treasurer pursuant to N.J.S.A. 10:5-31 et. seq., as supplemented and amended from time to time and the Americans with Disabilities Act. If the contractor or subcontractor is unable to obtain said assurances from the construction trade union at least five business days prior to the commencement of construction work, the contractor or subcontractor agrees to attempt to hire or schedule minority and women workers directly, consistent with the applicable employment goal. If the contractor's or subcontractor's prior experience with a construction trade union, regardless of whether the union has provided said assurances, indicates a significant possibility that the trade union will not refer sufficient minority and women workers consistent with the applicable employment goal, the contractor or subcontractor agrees to be prepared to hire or schedule minority and women workers directly, consistent with the applicable employment goal, by complying with the hiring or scheduling procedures prescribed under (2) below; and the contractor or subcontractor further agrees to take said action immediately if it determines or is so notified by the Division that the union is not referring minority and women workers consistent with the applicable employment goal.
- (2) If the hiring or scheduling of a workforce consistent with the employment goal has not or cannot be achieved for each construction trade by adhering to the procedures of (1) above, or if the contractor does not have a referral agreement or arrangement with a union for a construction trade, the contractor or subcontractor agrees to take the following actions consistent with the applicable county employment goals:
  - (a) To notify the public agency compliance officer, the Division, and minority and women referral organizations listed by the Division pursuant to N.J.A.C. 17:27-5.3, of its workforce needs, and request referral of minority and women workers;
  - (b) To notify any minority and women workers who have been listed with it as awaiting available vacancies;
  - (c) Prior to commencement of work, to request that the local construction trade union refer minority and women workers to fill job openings, provided the contractor or

subcontractor has a referral agreement or arrangement with a union for the construction trade;

- (d) To leave standing requests for additional referral to minority and women workers with the local construction trade union, provided the contractor or subcontractor has a referral agreement or arrangement with a union for the construction trade, the State Training and Employment Service and other approved referral sources in the area until such time as the workforce is consistent with the employment goal;
- (e) If it is necessary to lay off some of the workers in a given trade on the construction site, to assure, consistent with the applicable State and Federal statutes and court decisions, that sufficient minority and women employees remain on the site consistent with the employment goal; and to employ any minority and women workers so laid off by the contractor on any other construction site on which its workforce composition is not consistent with an employment goal established pursuant to rules implementing **N.J.S.A. 10:5-31 et. seq.**;
- (f) To adhere to the following procedure when minority and women workers apply or are referred to the contractor or subcontractor:
  - (1) If said individuals have never previously received any document or certification signifying a level of qualification lower than that required in order to perform the work of the construction trade, the contractor or subcontractor shall determine the qualifications of such individuals and if the contractor's or subcontractor's workforce in each construction trade is not consistent with the applicable employment goal, it shall hire or schedule those individuals who satisfy appropriate qualification standards. However, a contractor or subcontractor shall determine that the individual at least possesses the requisite skills, and experience recognized by a union, apprentice program or a referral agency, provided the referral agency is acceptable to the Division. If necessary, the contractor or subcontractor shall hire or schedule minority and women workers who qualify as trainees pursuant to these rules. All of the requirements, however, are limited by the provisions of (3) below.
  - (2) If the contractor's or subcontractor's workforce is consistent with the applicable employment goal, the name of any interested women or minority individual shall be maintained on a waiting list for the first consideration, in the event the contractor's or subcontractor's workforce is no longer consistent with the applicable employment goal.
  - (3) If, for any reason, said contractor or subcontractor determines that a minority individual or a woman is not qualified or if the individual qualifies as an advanced trainee or apprentice, the contractor or subcontractor shall inform the individual in writing of the reasons for the determination, maintain a copy of the determination in its files, and send a copy to the public agency compliance officer and to the Division.

- (g) To keep a complete and accurate record of all requests made for the referral of workers in any trade covered by the contract, on forms made available by the Division and submitted promptly to the Division upon request.
- ( 3 ) The contractor or subcontractor agrees that nothing contained in (2) above shall preclude the contractor or subcontractor from complying with the union hiring hall or apprenticeship policies in any applicable collective bargaining agreement or union hiring hall arrangement, and, where required by custom or agreement, it shall send journeymen and trainees to the union for referral, or to the apprenticeship program for admission, pursuant to such agreement or arrangement. However, where the practices of a union or apprenticeship program will result in the exclusion of minorities and women or the failure to refer minorities and women consistent with the county employment goal, the contractor or subcontractor shall consider for employment persons referred pursuant to (2) above without regard to such agreement or arrangement; provided further, however, that the contractor or subcontractor shall not be required to employ women and minority advanced trainees and trainees in numbers which result in the employment of advanced trainees and trainees as a percentage of the total workforce for the construction trade, which percentage significantly exceeds the apprentice to journey worker ratio specified in the applicable collective bargaining agreement, or in the absence of a collective bargaining agreement , exceeds the ratio established by practice in the area for said construction trade. Also, the contractor or subcontractor agrees that, in implementing the procedures of (2) above it shall, where applicable, employ minority and women workers residing within the geographical jurisdiction of the union.
- (4) After notification of award, but prior to signing a construction contract, the contractor shall submit to the public agency compliance officer and the Division an initial project workforce report (Form AA 201) provided to the public agency by the Division for distribution to and completion by the contractor, in accordance with N.J.A.C. 17:27-7. The contractor also agrees to submit a copy of the Monthly Project Workforce Report once a month thereafter for the duration of this contract to the Division and to the public agency compliance officer. The contractor agrees to cooperate with the public agency in the payment of budgeted funds, as is necessary, for on-the-job and/or off-the-job programs for outreach and training of minorities and women.
- (5) The contractor and its subcontractors shall furnish such reports or other documents to the Division of Contract Compliance & EEO as may be requested by the Division from time to time in order to carry out the purposes of these regulations, and public agencies shall furnish such information as may be requested by the Division of Contract Compliance & EEO for conducting a compliance investigation pursuant to **Subchapter 10 of the Administrative Code at N.J.A.C. 17:27.**



SECTION G

GENERAL SPECIFICATIONS

INDEX

SECTION NO.

TITLE

01060	Regulatory Requirements and Applicable Standards
01340	Shop Drawings, Product Data and Samples
01510	Environmental Protection
01545	Protection of Existing Utilities
01640	Substitutions
01700	Contract Closeout
01710	Cleaning and Restorations

## SECTION 01060

### REGULATORY REQUIREMENTS AND APPLICABLE STANDARDS

#### 1.1 DESCRIPTION

##### A. Work included:

1. Throughout the Contract Documents, reference is made to codes and standards which establish qualities and types of workmanship and materials, and which establish methods for testing and reporting on the pertinent characteristics.
2. Where materials or workmanship are required by these Contract Documents to meet or exceed the specifically named code or standard, it is the Contractor's responsibility to provide materials and workmanship which meet or exceed the specifically named code or standard.
3. It is also the Contractor's responsibility, when so required by the Contract Documents or by written request from the ENGINEER, to deliver to the ENGINEER all required proof that the materials or workmanship, or both, meet or exceed the requirements of the specifically named code or standard. Such proof shall be in the form requested in writing by the ENGINEER, and generally will be required to be copies of a certified report of test conducted by a testing agency approved for that purpose by the ENGINEER.

- B. Related work described elsewhere: Specific naming of codes or standards occurs on the drawings and in other section of these Specifications.

#### 1.2 QUALITY ASSURANCE

- A. Familiarity with pertinent codes and standards: In procuring all items used in this work, it is the Contractor's responsibility to verify the detailed requirements of the specifically named codes and standards and to verify that the items procured for use in this work meet or exceed the specified requirements.
- B. Rejection of noncomplying items: The ENGINEER reserves the right to reject items incorporated into the work which fail to meet the specified minimum requirements. The ENGINEER further reserves the right, and without prejudice to other recourse the ENGINEER may take, to accept noncomplying items subject to an adjustment in the Contract amount as approved by the ENGINEER and to the OWNER.
- C. Applicable standards listed in these specifications include, but are not necessarily limited to, standards promulgated by the following agencies and organizations:

1. AASHTO = American Association of State Highway and Transportation Officials  
341 National Press Building  
Washington, D.C. 20004
2. ACI = American Concrete Institute  
Box 19150, Redford Station  
Detroit, Michigan 48129
3. ANSI = American National Standards Institute  
(successor to USASI and ASI)  
1430 Broadway  
New York, NY 10018
4. ASTM = American Society for Testing & Materials  
1916 Race Street  
Philadelphia, PA 19103
5. AWWA = American Water Works Association, Inc.  
6666 West Quincy Avenue  
Denver, Colorado 80235
6. NEC = National Electrical Code (See NFPA)
7. NEMA = National Electrical Manufacturers Association  
155 East 44th Street  
New York, NY 10017
8. UL = Underwriters' Laboratories, Inc.  
207 East Ohio Street  
Chicago, Il 60611
9. NSPC = National Standard Plumbing Code  
1016 20th St., N.W.  
Washington, D.C. 20036
10. NFPA = National Fire Protection Association  
60 Batterymarch Street  
Boston, MA 02110
11. BOCA = The BOCA Basic Building Code Building Officials & Code Administrators International, Inc.  
17926 S. Halstead Street  
Homewood, Il 60430

12. NJDOT = Standard Specifications for Road and  
Bridge Construction  
New Jersey Department of Transportation  
Trenton, NJ 08625

END OF SECTION

## SECTION 01340

### SHOP DRAWINGS, PRODUCT DATA AND SAMPLES

#### 1.1 GENERAL

- A. Submit to ENGINEER shop drawings, product data and samples required by the Specifications sections.
- B. Related Requirements in other parts of the Contract Documents:  
  
Quality of Articles, Materials and Equipment: General Conditions.
- C. Schedule submission for shop drawings, product data and samples at least fourteen (14) working days before dates reviewed submittals will be needed.

#### 1.2 SHOP DRAWINGS

- A. Original drawings, prepared by Contractor, subcontractor, supplier or distributor, which illustrate some portion of the work; showing fabrication, layout, setting or erection details.
- B. Present drawings in a clear and thorough manner:  
  
Details shall be identified by reference to sheet and detail or schedule numbers shown on Contract Drawings.
- C. Minimum sheet size: 8 1/2-inches by 11-inches.

#### 1.3 PRODUCT DATA

- A. Preparation:
  - 1. Clearly mark each copy to identify pertinent products or models.
  - 2. Show performance characteristics and capacities.
  - 3. Show dimension and clearances required.
  - 4. Show wiring or piping diagrams and controls.
- B. Manufacturer's standard schematic drawings and diagrams:
  - 1. Modify drawings and diagrams to delete information not applicable to the work.

2. Supplement standard information to provide information specifically applicable to the work.
- C. Manufacturer's catalog sheets, brochures, diagrams, illustrations and other standard descriptive data:
1. Clearly mark each copy to identify pertinent materials, products or models.
  2. Show dimensions and clearances required.

#### 1.4 SAMPLES

- A. Office samples: Of sufficient size and quantity to clearly illustrate:
1. Functional characteristics of product or material with integrally related parts and attachment devices.
  2. Full range of color, texture, and pattern.
  3. After review, samples will be retained by ENGINEER. Upon completion of the work, Contractor may submit written request for return of samples.

#### 1.5 CONTRACTOR'S RESPONSIBILITIES

- A. Review shop drawings, product data and samples prior to submission.
- B. Determine and verify:
1. Field measurements.
  2. Field construction criteria.
  3. Catalog numbers and similar data.
  4. Conformance with specifications.
- C. Coordinate each submittal with requirements of the work and of the Contract Documents.
- D. Contractor's responsibility for errors and omissions in submittals is not relieved by ENGINEER's review of submittals.
- E. Contractor's responsibility for deviations in submittals from requirements of

Contract Documents is not relieved by ENGINEER'S review of submittals, unless ENGINEER gives written acceptance of specific deviations.

- F. Notify ENGINEER, in writing at time of submission, of deviations in submittals from requirements of Contract Documents.
- G. Begin no fabrication or work which requires submittals until return of submittals with ENGINEER'S stamp and initials or signature indicating review and approval.

## 1.6 SUBMISSION REQUIREMENTS

- A. Make submittals so as to cause no delay in the work or in the work of any other Contractor.

- B. Number of submittals required:

Shop drawings: Submit a minimum of six (6) legible reproductions of all complete and detail drawings to the ENGINEER for approval.

- C. Accompany submittals with transmittal letter, in duplicate containing:

1. Date of submission and dates of any previous submissions.
2. Project title and number.
3. Contractor's name and address.
4. The number of each shop drawing, product data and sample submitted.
5. Notification of deviations from Contract Documents.
6. Other pertinent data.

- D. Submittals shall include:

1. Date and revision date.
2. Project title and number.
3. The names of:
  - a. ENGINEER.
  - b. Contractor.
  - c. Subcontractor.

- d. Supplier.
  - e. Manufacturer.
  - f. Separate details when pertinent.
4. Identification of product or materials.
  5. Field dimensions clearly identified as such.
  6. Specification section number.
  7. Relation to adjacent or critical features of the work or materials.
  8. Applicable standards, such as ASTM or Federal Specification numbers.
  9. Identification of deviations from Contract Documents.
  10. Identification of revisions on resubmittals.
  11. An 8-inch by 3-inch blank space for Contractor and ENGINEER stamps.
  12. Contractor's stamp, initialed or signed, certifying to review of submittal, verification of products, field measurements and field construction criteria, and coordination of the information within the submittal with requirements of the work and of Contract Documents.

## 1.7 RESUBMISSION REQUIREMENTS

- A. Make any corrections or changes in the submittals required by the ENGINEER and resubmit until approved.
- B. Shop drawings and product data:
  1. Revise initial drawings or data, and resubmit as specified for the initial submittal.
  2. Indicate any changes which have been made other than those requested by the ENGINEER.
- C. Samples: Submit new samples as required for initial submittals.

## 1.8 DISTRIBUTION

- A. Distribute reproductions of Shop Drawings and copies of Product Data which



carry the ENGINEER stamp of approval to:

1. Subcontractors.
2. Supplier.
3. Contractor's file.

#### 1.9 ENGINEER DUTIES

- A. Review submittals with reasonable promptness.
- B. Review for:
  1. Design concept of project.
  2. Information given in Contract Documents.
- C. Review of separate item does not constitute review of an assembly in which item functions.
- D. Affix stamp and initials or signature certifying to review of submittal.
- E. Return submittals to Contractor for distribution or resubmission.

END OF SECTION

## SECTION 01510

### ENVIRONMENTAL PROTECTION

#### 1.1 GENERAL

The work covered by this Section consists of furnishing all labor, materials, and equipment, and performing of all work required for the prevention of environmental pollution during, and as the result of, construction operations under this Contract. For the purpose of this Specification, environmental pollution is defined as the presence of chemical, physical, or biological elements or agents which adversely affect human health or welfare, unfavorably alter ecological balances of importance to human life, or affect other species of importance to man. The control of environmental pollution requires consideration of air, water and land.

#### 1.2 APPLICABLE REGULATIONS

The Contractor and his subcontractors, in the performance of this Contract, shall comply with all applicable federal, state, and local laws and regulations concerning environmental pollution control and abatement in effect on the date of this solicitation, as well as specific requirements stated elsewhere in this Specification as applicable.

#### 1.3 NOTIFICATION

The ENGINEER will notify the Contractor of any noncompliance with the foregoing provisions and the corrective action to be taken. The Contractor shall, after receipt of such notice, take corrective action immediately. If the Contractor fails or refuses to comply promptly, the ENGINEER may issue an order stopping all or part of the work until satisfactory corrective action has been taken. No part of time lost due to any such stop order shall be made the subject of a claim for extension of time or for excess costs or damages by the Contractor unless it is later determined that the Contractor was in compliance.

#### 1.4 SUBCONTRACTORS

Compliance with the provisions of this Section by subcontractors will be the responsibility of the Contractor.

#### 1.5 DUST CONTROL

The Contractor shall maintain all work areas free from dust that would contribute to air pollution. Dust control shall be performed as the work proceeds and whenever dust nuisance or hazard occurs.

#### 1.6 PROTECTION OF LAND RESOURCES

It is intended that the land resources within the project boundaries and outside the limits of

permanent work performed under this Contract be preserved in their present condition or be restored to a condition after completion of construction that will not detract from the appearance of the project. Insofar as possible, the Contractor shall confine his construction activities to areas defined by the Plans and Specifications or to be cleared for other operations.

#### 1.7 PAYMENT

Unless otherwise indicated in the Proposal Section of these Specifications, costs incurred by the Contractor for items of ENVIRONMENTAL PROTECTION shall be reflected in the overall contract price.

END OF SECTION

## SECTION 01545

### PROTECTION OF EXISTING PUBLIC UTILITIES

#### 1.1 SECTION INCLUDES

- A. Definitions
- B. Diligent Inquiry
- C. Notification
- D. Avoid Damage and Protect Utilities
- E. Notification of Damage and Costs
- F. Contractor Convenience

#### 1.2 APPROXIMATE LOCATION OF UTILITIES

- A. The contractor will note that the horizontal and vertical location of all underground utilities shown on the contract drawings is approximate only and no guarantee is herein implied that all existing underground utilities or services are shown thereon.

#### 1.3 DEFINITIONS

- A. The terms public utility or public utilities used in this article shall be construed to include those publicly and privately owned.

#### 1.4 DILIGENT INQUIRY

- A. Within the site of the Project there may be public utility structures, and notwithstanding any other clause or clauses of this Contract, the Contractor shall not proceed with his work until he has made diligent inquiry of the offices of the ENGINEER, the utility companies and municipal authorities or other utilities to determine their exact location.

#### 1.5 NOTIFICATION

- A. The Contractor shall notify the Garden State Utility Location Service "one-call" system (1-800-272-1000) at least three (3) days prior to construction for mark out of all public utilities. Contractor shall supply ENGINEER with the one-call system certification number.

- B. The Contractor shall notify, in writing, the utility companies and municipalities or other utilities involved of the nature and scope of the Project and of his operations that may affect their facilities or property. Two copies of such notices shall be sent to the ENGINEER.

#### 1.6 AVOID DAMAGE AND PROTECT UTILITIES

- A. The Contractor shall carry out his work carefully and skillfully and shall support and secure public utility structures so as to avoid damage to them. Flow in drains and sewers shall be satisfactorily maintained. He shall not move without the utilities written consent any public utility structures, and at the completion of the work their condition shall be as safe and permanent as before.

#### 1.7 NOTIFICATION OF DAMAGE AND COSTS

- A. When public utility structures, facilities or equipment are damaged by the Contractor, he shall notify the utilities, who may cause the damage to be repaired at the Contractor's expense.
- B. If the cost thereof be not paid by the Contractor within 30 days after repairs have been completed, the Owner, as defined in this Contract, may retain an amount sufficient to cover the cost from any monies due or that may become due to the Contractor under this contract.

#### 1.8 CONTRACTOR CONVENIENCE

- A. When the removal, relocation or replacement of public utility structures or facilities is not deemed essential by the ENGINEER for carrying out the Project as planned, but is performed for the Contractor's convenience, the cost of such work shall be included in the prices bid for the various items scheduled in the Proposal. When such removal, relocation or replacement is deemed essential by the ENGINEER for carrying out the work of the Project as planned, the cost shall be borne by the Owner or the owner utility.

END OF SECTION

## SECTION 01640

### SUBSTITUTIONS

#### 1.1 GENERAL

Related requirements specified elsewhere:

1. Substitutions during bidding: Instructions to Bidders.
2. Shop Drawings, Product Data and Samples: Section 01340

#### 1.2 SUBSTITUTIONS

- A. Within fifteen (15) days after Notice to Proceed ENGINEER will consider formal requests from Contractor for products in place of those specified.
- B. Submit four (4) copies of request for substitution. Include in request as applicable:
  1. Complete data substantiating compliance of proposed substitution with Contract Documents.
  2. For products:
    - a. Product identification, including manufacturer's name and address.
    - b. Manufacturer literature:
      - (1) Product description
      - (2) Performance and test data
      - (3) Reference standards
    - c. Samples
    - d. Name and address of similar projects on which product was used, and date of installation.
  3. For construction methods:
    - a. Detailed description of proposed method.
    - b. Drawings illustrating methods.
  4. Itemized comparison of proposed substitution with product or method specified.

5. Accurate cost data on proposed substitution as for product or method specified.
  6. Relation to separate contracts.
- C. In making requests for substitution, Bidder represents:
1. He has personally investigated proposed product or method and determined that it is equal or superior in all respects to that specified.
  2. He will provide the same guarantee for substitution as for product or method specified.
  3. He will coordinate installation of accepted substitution into work making such changes as may be required for work to be completed in all respects.
  4. He waives all claims for additional costs related to substitutions which consequently become apparent.
  5. Cost data is complete and includes all related costs under this contract.
- D. Substitutions will not be considered if:
1. They are indicated or implied on shop drawings of product data submittals without formal request submitted in accordance with Paragraph 1.02.
  2. Acceptance will require substantial revision of Contract Documents.

END OF SECTION

SECTION 01700  
CONTRACT CLOSEOUT

1.1 SECTION INCLUDES

- A. Closeout procedures.
- B. Final cleaning.
- C. Adjusting.
- D. Project record documents.
- E. Operation and maintenance data.
- F. Warranties.
- G. Spare parts and maintenance materials.

1.2 CLOSEOUT PROCEDURES

- A. Submit written certification that Contract Documents have been reviewed, Work has been inspected, and that Work is complete in accordance with Contract Documents and ready for ENGINEER's inspection.
- B. Provide submittals to ENGINEER that are required by governing or other authorities.
- C. Submit the following documents:
  - 1. Application for Final Payment.
  - 2. Form of Contractor's Certificate (page J-17 of the Contract).
  - 3. Statement of Surety Company (form at the end of this section).
  - 4. Project Record Documents.

1.3 FINAL CLEANING

- A. Execute final cleaning prior to final inspection.
- B. Clean site.
- C. Remove waste and surplus materials, rubbish, and construction facilities from the site.



## 1.4 PROJECT RECORD DOCUMENTS

- A. Maintain on site, one set of the following record documents; record actual revisions to the Work:
  - 1. Contract Drawings.
  - 2. Specifications.
  - 3. Addenda.
  - 4. Change Orders and other Modifications to the Contract.
  - 5. Reviewed shop drawings, product data, and samples.
- B. Store Record Documents separate from documents used for construction.
- C. Record information concurrent with construction progress.
- D. Specifications: Legibly mark and record at each Product section description of actual Products installed, including the following:
  - 1. Manufacturer's name and product model and number.
  - 2. Product substitutions or alternates utilized.
  - 3. Changes made by Addenda and Modifications.
- E. Record Documents and Shop Drawings: Legibly mark each item to record actual construction including:
  - 1. Measured horizontal and vertical locations of underground utilities and appurtenances, referenced to permanent surface improvements.
  - 2. Field changes of dimension and detail.
  - 3. Details not on original Contract Drawings.
- F. Delete ENGINEER title block from all documents.
- G. Submit documents to ENGINEER with claim for final Application for Payment.

END OF SECTION

## SECTION 01710

### CLEANING AND RESTORATIONS

#### 1.1 DESCRIPTION

- A. Related work specified elsewhere:
  - 1. General requirements for cleaning and restorations: See the General Conditions.
  - 2. Cleaning for specific products or work: Specification Section for that work.
- B. Maintain premises and public properties free from accumulations of waste, debris and rubbish caused by work operations.
- C. During the course of the work, remove waste materials, rubbish, tools, equipment, machinery and surplus materials; clean all sight exposed surfaces; leave project clean and ready for occupancy.
- D. Restore or replace, when and as directed by the ENGINEER, any public or private property disturbed or damaged by Contractor's work operations to a condition at least equal to that existing prior to beginning work, or as otherwise specified. Materials, equipment and methods shall be approved by the ENGINEER. These restorations shall include areas used by the Contractor for temporary storage of materials and for equipment.

#### 1.2 METHODS OF CONDUCTING WORK - CLEANING

- A. Requirements of regulatory agencies: Dispose of all solid waste materials in permanently established licensed OSWA (Office of Solid Waste Administration, New Jersey Department of Environmental Protection) landfills, or in temporary landfill sites approved by OSWA.
- B. Safety requirements:
  - 1 Hazards control:
    - a) Store volatile wastes in covered metal containers and remove from premises daily.
    - b) Prevent accumulation of wastes which create a hazardous condition.
    - c) Provide adequate ventilation during use of volatile or noxious substances.

2. Conduct cleaning and disposal operations to comply with local ordinances and anti-pollution laws:

- a) Do not burn or bury rubbish and waste materials on project site.
- b) Do not dispose of volatile wastes such as mineral spirits, oil or paint thinner in storm or sanitary drains.
- c) Do not dispose of wastes into streams or waterways.

C. Cleaning during construction:

- 1. Execute periodic cleaning to keep the work and the site free from accumulations of waste materials, rubbish and debris resulting from construction operations.

D. Dust control:

- 1. The Contractor shall employ construction methods and means that will keep flying dust to the minimum. The cost of carrying out the foregoing provisions shall be included in the prices bid for the various items in the Contract.

E. Final cleaning:

- 1. Employ skilled workmen for final cleaning.
- 2. Prior to final acceptance, Contractor shall conduct an inspection of all work areas to verify that the entire work is clean.

### 1.3 METHODS OF CONDUCTING WORK - RESTORATIONS

A. General: All existing structures and areas disturbed or damaged during the work under this Contract shall be restored or replaced to a condition at least equal to that existing prior to beginning work, or as otherwise specified.

### 1.4 QUANTITY AND PAYMENT

All costs for CLEANING AND RESTORATIONS shall be included in prices bid for various items scheduled in the Proposal.

END OF SECTION



SECTION H

TECHNICAL SPECIFICATIONS

INDEX

TITLE

AUDIO EQUIPMENT

LIGHTING EQUIPMENT



# LIGHTING TECHNICAL SPECIFICATIONS



## KEY FEATURES

- Portable and compact fully featured lighting console
- Adjustable 15.6" Full HD multi touch screen, 2x external 4K Touch Displays
- 64 Universe integrated processing
- 10 Playbacks, 8 Encoders, Keypad and internal 3.5" touchscreen
- Network, DMX, Timecode and Midi Connectivity

## SPECIFICATIONS

### SURFACE

- 10 x 60 mm playback faders, each with 4 x function-assignable buttons
- 8 x customizable multi-function keys
- Playback Select button
- Master Go section with Go, Pause, Snap and Release
- 4 x digital rotary encoders with push function and status LED for fixture parameter control
- 4x screen mounted digital rotary encoders with push function
- 3.5" RGB touchscreen for parameter groups, effect parameters, fanning and global timings
- Grand master rotary fader and button
- Blind/HighLight/Last/Next buttons
- Full numerical keypad and command keys

### HARDWARE

- Industrial motherboard with Intel i5 Hexa-Core CPU
- Quiet thermal design using advanced copper heat pipe coolers
- 16 GB DDR4 RAM
- Integrated graphics processor
- Windows 10 IoT Embedded Operating System
- OS installation by USB 3.0 storage device
- Supports Windows USB touchscreens

NX2



## CONNECTIONS

4 x DMX / RDM Universe In/Out: 5-pin locking XLR  
 External Display: 2x DisplayPort (up to 4k)  
 Network: 2x Gigabit for Art-Net, sACN and ONYX X-Net  
 Storage and Peripherals: 4x USB 3.0, 1x USB 2.0  
 Audio Out, Mic In: 2x 3.5mm Jack  
 MIDI in/out/thru (MIDI Showcontrol, MIDI notes, MIDI Timecode): 5pin DIN  
 SMPTE Timecode In/Out: 3-pin XLR  
 12 VDC power supply input: 4-pin XLR  
 Desk lamp: XLR 12V  
 USB In: USB 2.0 B

## PHYSICAL

Length: 300 mm (11.9 in.)  
 Width: 540 mm (21.3 in.)  
 Height: 121 mm (4.8 in.)  
 Weight: 9 kg (19.8 lbs.)

## ELECTRICAL

AC mains power to 12VDC external PSU (included):  
 100-240V nominal, 50/60 Hz  
 Maximum current: 3A  
 12VDC output: 11A, 132W max.

## ORDERING

### INCLUDED ITEMS

RGB LED desk lamp, angular XLR connector, 13"  
 Dust Cover  
 Obsidian USB Cable  
 External PSU (12V 11A)  
 1.5 m power cable, 3-pin IEC

### SKU

US #: NX2984  
 EU #: 1330000047

### OPTIONAL ITEMS

DRCNX2

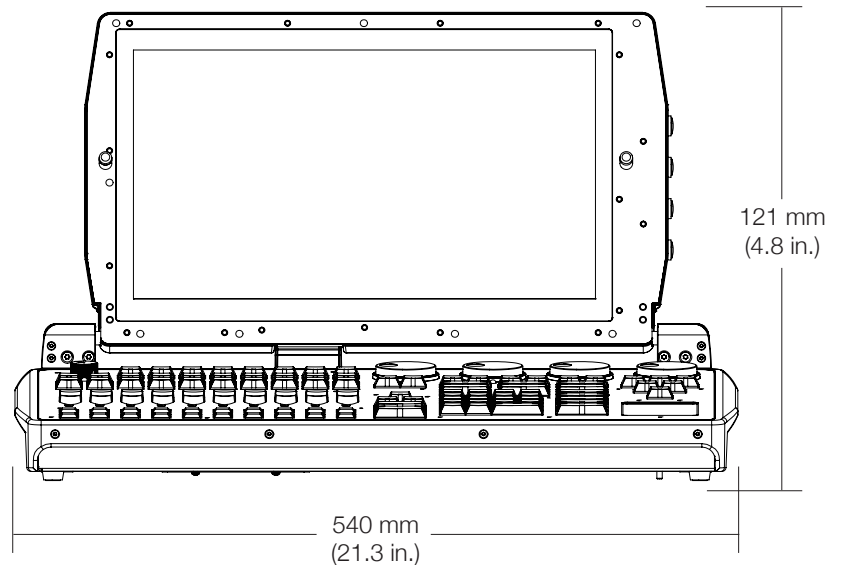
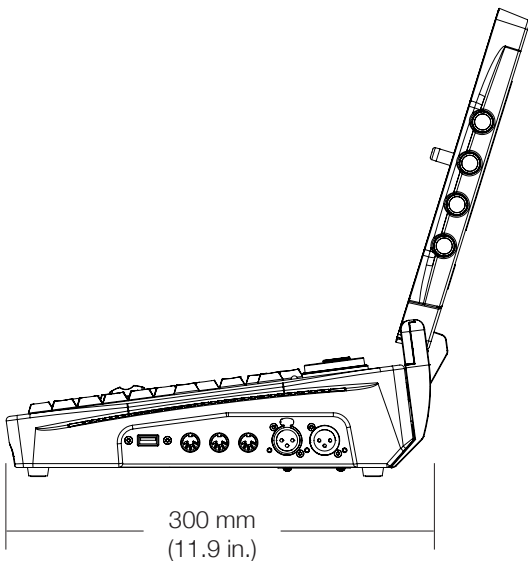



# 290mm/Square Truss

SKU: N/A  
 Categories: G-Truss, Spigot Truss  
 Tag: G-Truss

Our 290mm GT-Truss (GT-290) is a 4-point truss system. This provides optimum volume and load capacity for its construction size and a tube diameter of 50mm. This system is connected via a special conical connector system, which is joined together to a complete form fit by means of a copper hammer, creating optimal traction. It is also characterized by a minimum transport volume and the special lightweight design. The conical connectors are of course included in the scope of delivery – special designs and powder coatings can be carried out at short notice. This size truss is meant for a more light duty design.

**Color Options:** Silver or Black (Powder Coated)

**Size Options:** 1m/2m/3m

**\* (Please review load chart for more details)**

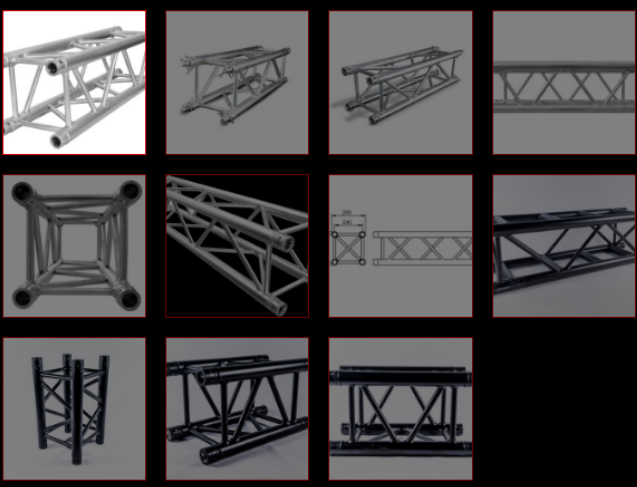

**Description    Additional information    Load Chart    Technical Data    Reviews (0)**

L (m / ft)	UDL		FLECHA DEFLECTION		UDL + PA		FLECHA DEFLECTION		L/2		L/3		L/4		L/5		L/6		L/7		L/8		L/9		FLECHA DEFLECTION		RESO TOTAL TOTAL WEG	
	kg / m	lbs / ft	mm	inch	kg / m	lbs / ft	mm	inch	kg	lbs	kg	lbs	kg	lbs	kg	lbs	kg	lbs	kg	lbs	kg	lbs	kg	lbs	mm	inch	kg	lbs
3/9,9	681	458,3	9	0,4	581	391,0	8	0,3	1464	3232,1	1022	2255,4	681	1503,6	511	1127	409	902,1	341	751,8	292	644,4	255	563,8	8	0,3	15	33,8
4/13,2	510	342,9	16	0,6	435	292,4	15	0,6	1094	2414,2	820	1810,7	547	1207,1	454	1001	365	804,7	319	704,1	273	603,6	246	543,2	15	0,6	20	45,0
5/16,5	348	234,2	25	1,0	282	189,4	24	0,9	870	1921,2	653	1440,9	435	960,6	361	797,3	290	640,4	254	560,4	218	480,3	196	432,3	23	0,9	26	56,3
6/19,8	240	161,6	36	1,4	193	130,1	34	1,3	721	1590,7	540	1193,0	360	795,4	299	660,1	240	530,2	210	464,0	180	397,7	162	357,9	33	1,3	31	67,5
7/23,1	175	117,8	49	1,9	140	94,4	46	1,8	613	1353,0	460	1014,8	306	676,5	254	561,5	204	451,0	179	394,6	153	338,3	138	304,4	44	1,7	36	78,8
8/26,4	133	89,4	64	2,5	106	71,2	60	2,4	532	1173,3	399	880,0	266	586,7	221	486,9	177	391,1	155	342,2	133	293,3	120	264,0	58	2,3	41	90,1
9/29,7	104	69,9	80	3,2	82	55,3	76	3,0	468	1032,3	351	774,2	234	516,2	194	428,4	156	344,1	136	301,1	117	258,1	105	232,3	73	2,9	46	101,3
10/33,0	83	56,0	99	3,9	65	43,9	94	3,7	416	918,4	312	688,8	208	459,2	173	381,1	139	306,1	121	267,9	104	229,6	94	206,6	91	3,6	51	112,6
11/36,3	68	45,7	120	4,7	53	35,5	114	4,5	373	824,2	280	618,1	187	412,1	155	342,0	124	274,7	109	240,4	93	206,0	84	185,4	110	4,3	56	123,8
12/39,6	56	37,8	143	5,6	43	29,1	136	5,3	337	744,7	253	558,5	169	372,3	140	309,0	112	248,2	98	217,2	84	186,2	76	167,6	131	5,1	61	135,1
13/42,9	47	31,73	168	6,61	36	24,08	159	6,2	306	676,58	230	507,44	153	338,29	127	280,7	102	225,5	89	197,3	77	169,1	69	152,2	153	6	66	146,3
14/46,2	40	26,88	195	7,66	30	20,12	185	7,2	280	617,40	210	463,05	140	308,70	116	256,2	93	205,8	82	180	70	154,3	63	138,9	178	7	71	157,6
15/49,5	34	22,98	223	8,80	25	16,93	212	8,3	256	565,36	192	424,02	128	282,68	106	234,6	85	188,4	75	164,9	64	141,3	58	127,2	204	8	77	168,8
16/52,8	29	19,78	254	10	21	14,32	241	9	235	519,11	176	389,34	118	259,56	98	215,4	78	173	69	151,4	59	129,7	53	116,8	232	9,1	82	180,1

# P2 T

## LED PROFILE SPOTLIGHT WITH TUNGSTEN LED



### FEATURES

- ▶ LED profiler with 230 W Tungsten COB LED
- ▶ High CRI (>97Ra) and TLCI (>93) for natural colour rendering
- ▶ 14,000 lm luminous flux replaces conventional 750 W profile spotlight with halogen bulb
- ▶ Colour temperature: 3,200 K (warm white)
- ▶ Interchangeable fixed optics (19°, 26°, 36°, 50°) and zoom optics (15°-30°, 25°-50°)
- ▶ Time-saving Quicklight function with push encoder operation
- ▶ Selectable pulse width modulation (up to 25 kHz) for flicker-free operation
- ▶ Control via DMX, RDM or W-DMX (via optional Cameo iDMX Stick)
- ▶ Silent fan with different fan modes for every application area



### DESCRIPTION

Whether in the theatre, on a TV show or on an event stage - people and objects must always be optimally illuminated to give spectators and cameras a perfect picture of the action. To meet the requirements of lighting designers, directors, agencies, artists or company directors in any situation, Cameo has developed the P series: LED profile spotlights for the professional theatre, TV and event sector.

Anyone who sets people and objects in motion in scene with just one light beam must be able to rely on two aspects: Handling and light quality. The P2 T convinces in both disciplines. The 230 W daylight COB LED emits a high-quality warm white light (3,200 K) with 14,000 lm luminous flux and is the perfect replacement for conventional, power-hungry 750 W profile spotlights in theatres, musicals, TV studios, at congresses or event stages in the live and corporate sector. Equipped with a particularly high CRI of over 97Ra and a TLCI value of over 93, people and objects shine in perfectly defined light at all times.

The profilers of the Cameo P series can be flexibly adapted to different stage requirements via a variety of optional interchangeable lenses. There is a choice of interchangeable lenses with fixed beam angles (19°, 26°, 36° and 50°) as well as zoom lenses for the ranges 15°-30° and 25°-50°.

The unique Quicklight function makes aligning the profile spotlight much easier: simply unplug the DMX signal briefly and use the push encoder to turn up the brightness for lighting and adjust the spotlight. Even more versatile is the use in combination with the optionally available Cameo iDMX Stick to control the P2 T not only via DMX and RDM, but also wirelessly via W-DMX.

In the development of the P-series, Cameo deliberately took its cue from the highly successful theatre and TV spotlights of the F-series. Thus, the F and P series harmonise with each other both visually and in terms of their photometric properties, forming a perfectly matched lighting duo for theatres, TV, congresses and corporate events.

# P2 T

## LED PROFILE SPOTLIGHT WITH TUNGSTEN LED



### PHOTOMETRICAL DATA

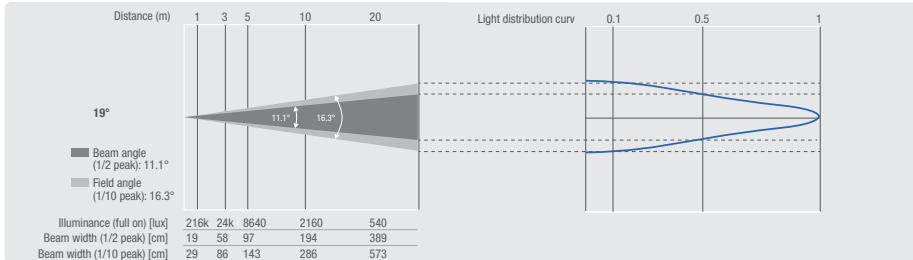

	Luminous flux	Chromaticity coordinates	CCT	R <sub>a</sub>
Full on	14010 lm	x 0.419 y 0.395	3252	97

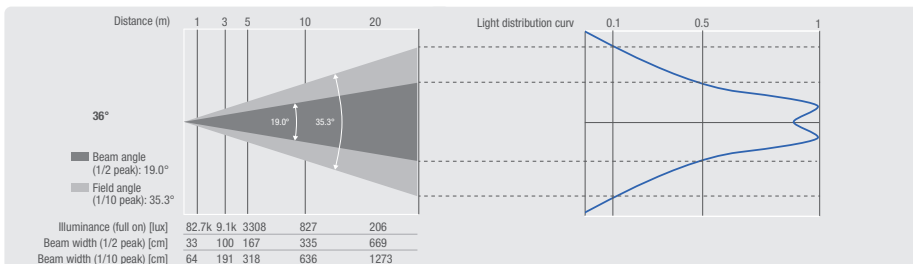
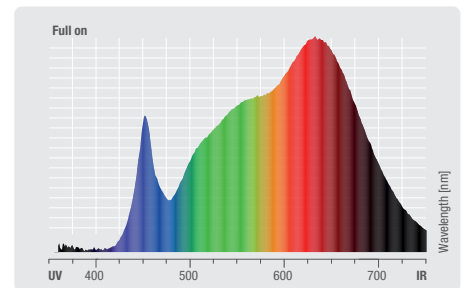
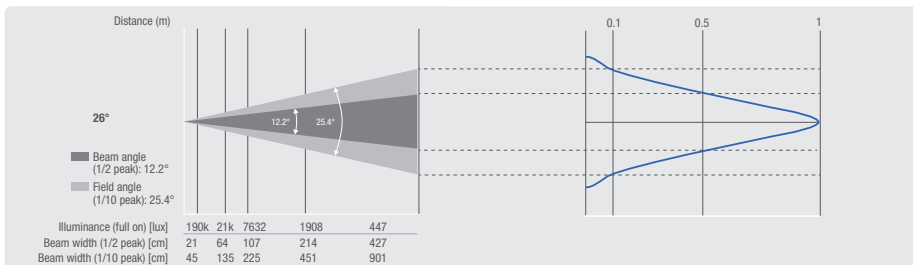

### SPECIFICATIONS

Product type	LED profile spotlight
Colour spectrum	Tungsten, Warm White
Color temperature	3200 K
Luminous flux	14000 lm
Refresh rate	800 - 25000 Hz
Lenses (optional)	Interchangeable Lens-Tubes
Dispersion	15 - 30 °, 19 °, 25 - 50 °, 26 °, 36 °, 50 °
Inputs	iDMX slot, XLR (5-pin)
Outputs	XLR (5-pin)
Dimmer curves	Exponential, Linear, Logarithmic, Square
Dimmer resolution	16 bit
Strobe	0 - 20 Hz
CRI	>97 Ra
TLCI	>93
Control	DMX, Master / Slave mode, RDM, Standalone, W-DMX via iDMX stick
DMX Functions	Device Settings, Dimmer, Dimmer Curve, strobe
System settings	Default settings, Dimmer, Dimmer Response, Display, Fan mode, LED PWM Frequency, Signal Fail, Wireless
Controls	OLED Display, Push & turn encoder

Protection class IP	IP20
Ambient temperature (operating)	-10 - 40 °C
Relative Humidity	< 80 %, not condensing
Cooling	Convection, low-noise fan
Operating voltage	100 V AC - 240 V AC, 50 - 60 Hz
Power connector	TRUE1 Compatible Power I/O Socket
Housing material	Die-cast aluminium, Magnesium
Cabinet colour	Black
Weight	10,5 kg
<b>Dimensions without lens top</b>	
Width	245 mm
Height	202 mm
Depth	462 mm

Features and specifications subject to change without notice.

[adamhall.com](http://adamhall.com)

# P2 T

LED PROFILE SPOTLIGHT WITH TUNGSTEN LED



## DIMENSIONS (mm)

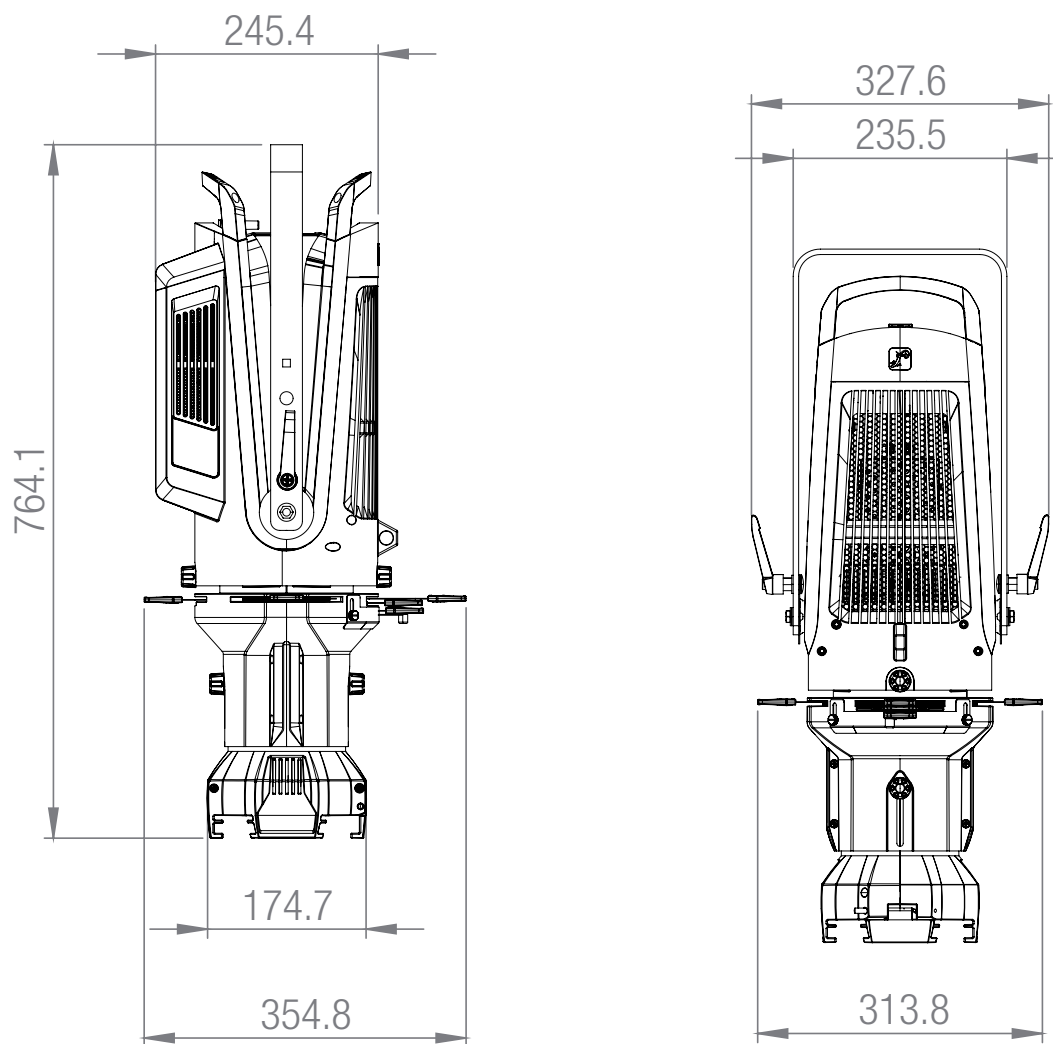

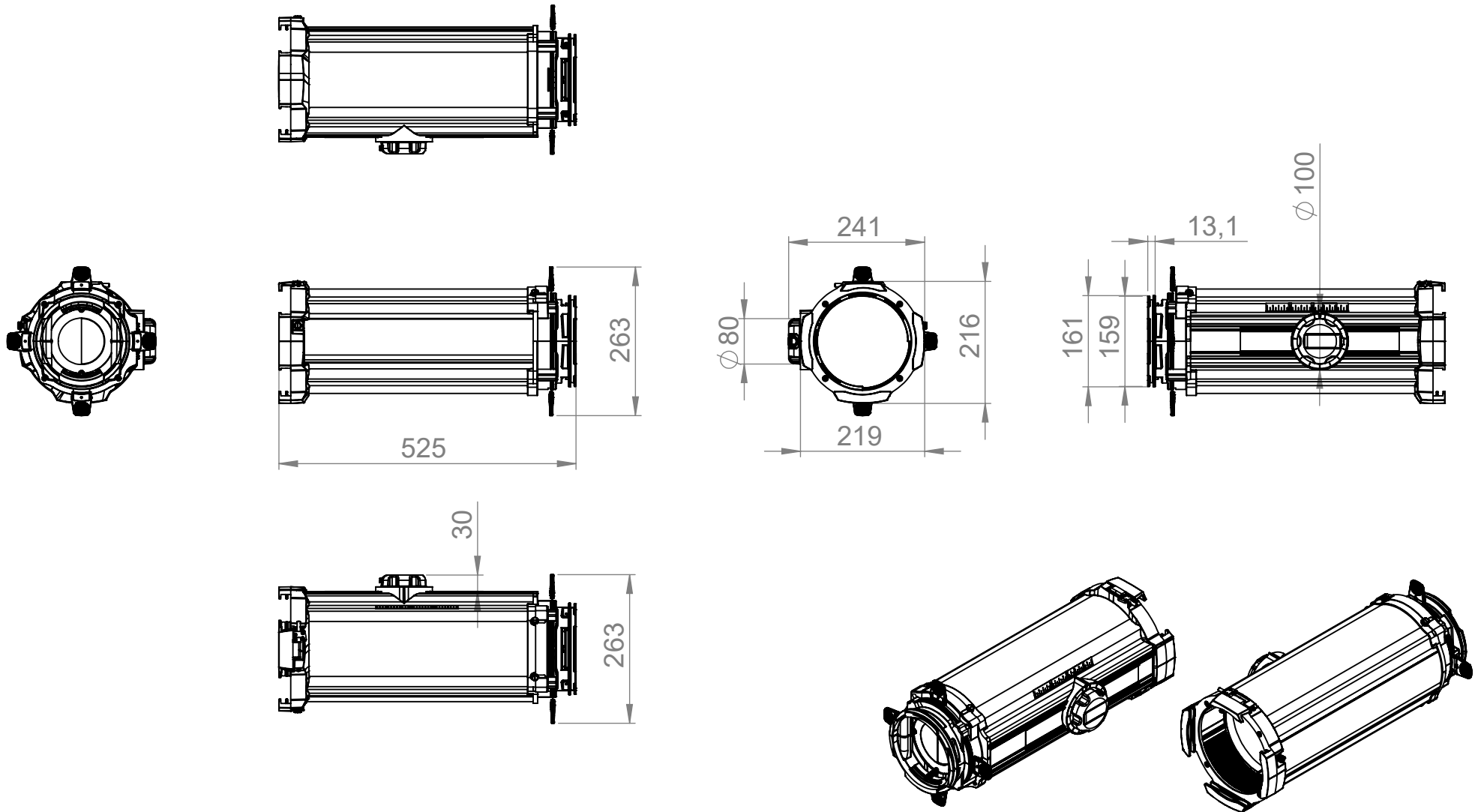

## 15°-30° Zoom Lens for P2 D/FC/T

Art No. CLP21530ZLENS

Scale: 1:10



Cameo® is a registered brand of the Adam Hall Group.  
 Adam-Hall-Str. 1 · 61267 Neu-Anspach · Germany  
 DESIGNED AND ENGINEERED IN GERMANY. Assembled in PRC

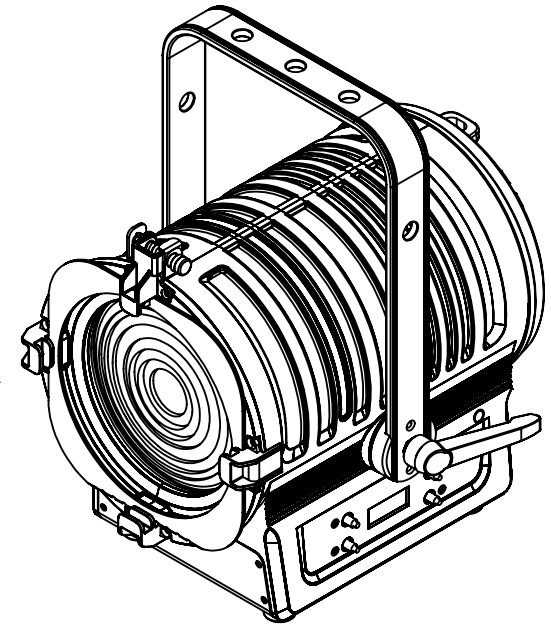
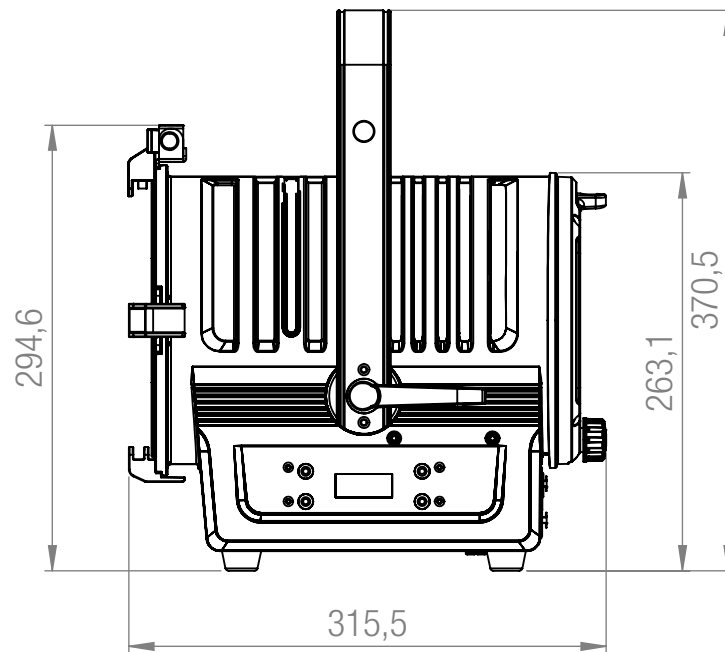
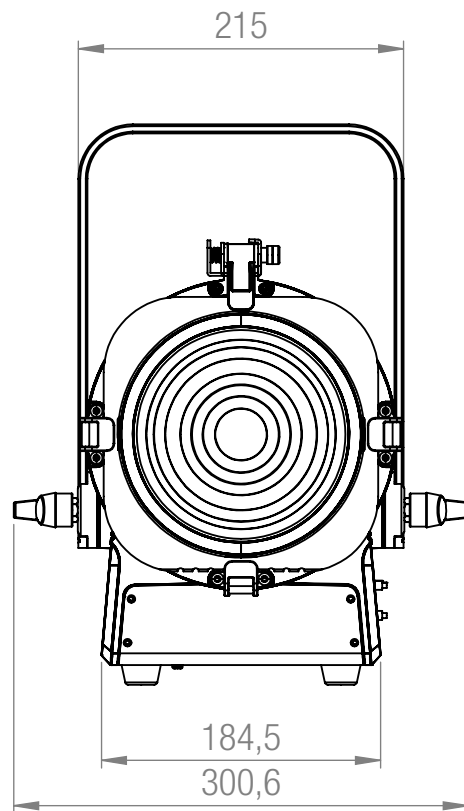

## THEATER SPOT 200 FC

Art No. CLTS200FC

Scale 1:5  
08.07.2019  
V1



Cameo® is a registered brand of the Adam Hall Group  
Adam Hall GmbH | Adam-Hall-Str. 1 | 61267 Neu-Anspach | Germany  
Phone: +49 6081 9419-0 | adamhall.com

Adam Hall übernimmt keine Gewähr oder Haftung für die Richtigkeit, Genauigkeit und Vollständigkeit dieser Zeichnung | Adam Hall accepts no responsibility for the correctness, accuracy and completeness for this illustration

# AZOR® S2

COMPACT SPOT MOVING HEAD



## FEATURES

- ▶ Compact spot moving head
- ▶ 300 W LED illuminant with 13,000 lm luminous flux
- ▶ Zoom range: 5° - 50°
- ▶ CMY colour mixing
- ▶ Additional colour wheel with 8 dichroic colour filters
- ▶ Rotating gobo wheel with 8 indexable/rotatable, exchangeable glass gobos + open
- ▶ Static gobo wheel with 11 gobos + open
- ▶ Selectable PWM frequencies up to 25 kHz for flicker-free operation
- ▶ Neutrik True1-compatible inputs/outputs
- ▶ OLED display with 4 buttons



## DESCRIPTION

Every year, countless artists, bands, actors and presenters stand on small to medium-sized stages and need light! For all these events, Cameo has developed the AZOR® S2. The compact spot moving head is the ideal partner for lighting designers and event service providers who are looking for a powerful and versatile LED show light that does not lack professional features despite its compact size.

The AZOR® S2 is based on a 300 W LED light source with 13,000 lumens of luminous flux and a wide zoom range of 5°-50° for precise adjustment of the light beam on any stage. The integrated rotating CMY colour mixing system is complemented by an additional colour wheel with 8 dichroic filters to perform lightning-fast colour changes and split colours in conjunction with the 630° pan and 270° tilt movement.

The AZOR® S2 is even more flexible thanks to the two gobo wheels with 8 rotating or 11 static gobos (each plus open). Additional effect options are created by the different prisms, both of which can be rotated and indexed.

Thanks to the adjustable PWM frequency (650 Hz - 25 kHz), the AZOR® S2 is also suitable for use in TV and broadcast applications as well as wherever a camera transmits the action and is dependent on flicker-free LEDs in the picture.

The compact spot moving head can be controlled via DMX512, RDM or wirelessly via W-DMX using the optional Cameo iDMX adapter. On the spotlight itself, buttons and an OLED display provide a convenient basic setup.



# AZOR<sup>®</sup> S2

## COMPACT SPOT MOVING HEAD



### PHOTOMETRICAL DATA

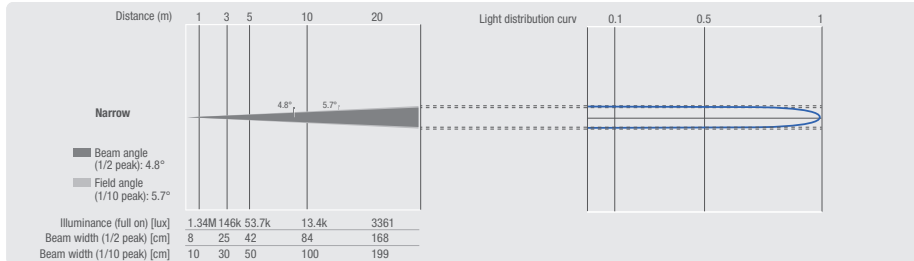

	Luminous flux	Chromaticity coordinates	CCT	R <sub>a</sub>
Full on	13000 lm	x 0.312 y 0.331	6500	69
High CRI	7400 lm	x 0.324 y 0.327	5900	86

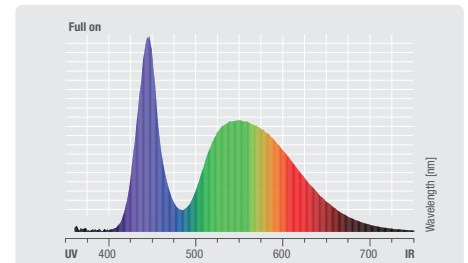
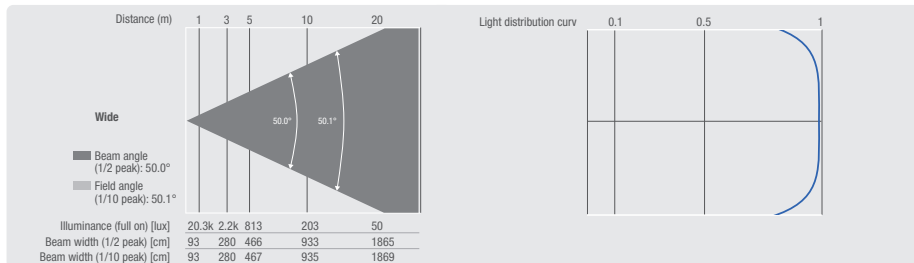

### SPECIFICATIONS

Product type	LED Moving Lights
Type	Spot
Colour spectrum	Cold white
Number of LEDs	1
Color temperature	6800 K
LED type	300 W
Colour mixing system	CMY
Refresh rate	650 - 25000 Hz
Dispersion	5° - 50°
Number of colours	8 + open and stepless colour wheel positioning
Number of gobos	11 fixed + 8 rotatable & inzable + open
DMX input	5-Pol XLR
DMX output	5-Pol XLR
Protocols	W-DMX (via iDMX Stick + Link)
Control	DMX512, iDMX Stick compatible, RDM
DMX mode	21-channel basic, 24-channel standard, 28-channel extended
DMX Functions	CMY, Colour wheel, Device Settings, Dimmer, Dimmer Fine, Focus, Focus Fine, Frost, Gobo Wheel 1, Gobo wheel 1 rotation, Gobo wheel 1 rotation fine, Gobo Wheel 2, Iris, Pan/Tilt, Pan/Tilt fine, Prism 1/2, Prism Selection, Strobe, Zoom, Zoom Fine
PAN movement	540°, 630°

TILT movement	270°
Standalone modes	Master / Slave mode, User Preset 1-4
Controls	Down, Enter, Mode, Up
Indicators	Battery supply for mains-independent system settings (automatically rechargeable battery), OLED Display
Operating voltage	100 V AC - 240 V AC, 50 - 60 Hz
Power consumption	470 W
Fuse	T4AL 250 V
Power connector	TRUE1 compatible input and output (max. output current 12A)
Max. output current	9 A
Housing material	ABS plastic, Metal
Cabinet colour	Black
Protection class IP	IP20
Cooling	Temperature-controlled fan
Luminous flux	13000 lm
Maximum Ambient Temperature	0 - 40 °C
Accessories (included)	2 x Omega mounting, Power cord
<b>Dimensions without mounting bracket</b>	
Width	372 mm
Height	601 mm
Depth	238 mm
Weight	19.7 kg

Features and specifications subject to change without notice.

[adamhall.com](http://adamhall.com)

# AZOR<sup>®</sup> S2

COMPACT SPOT MOVING HEAD



## DIMENSIONS (mm)

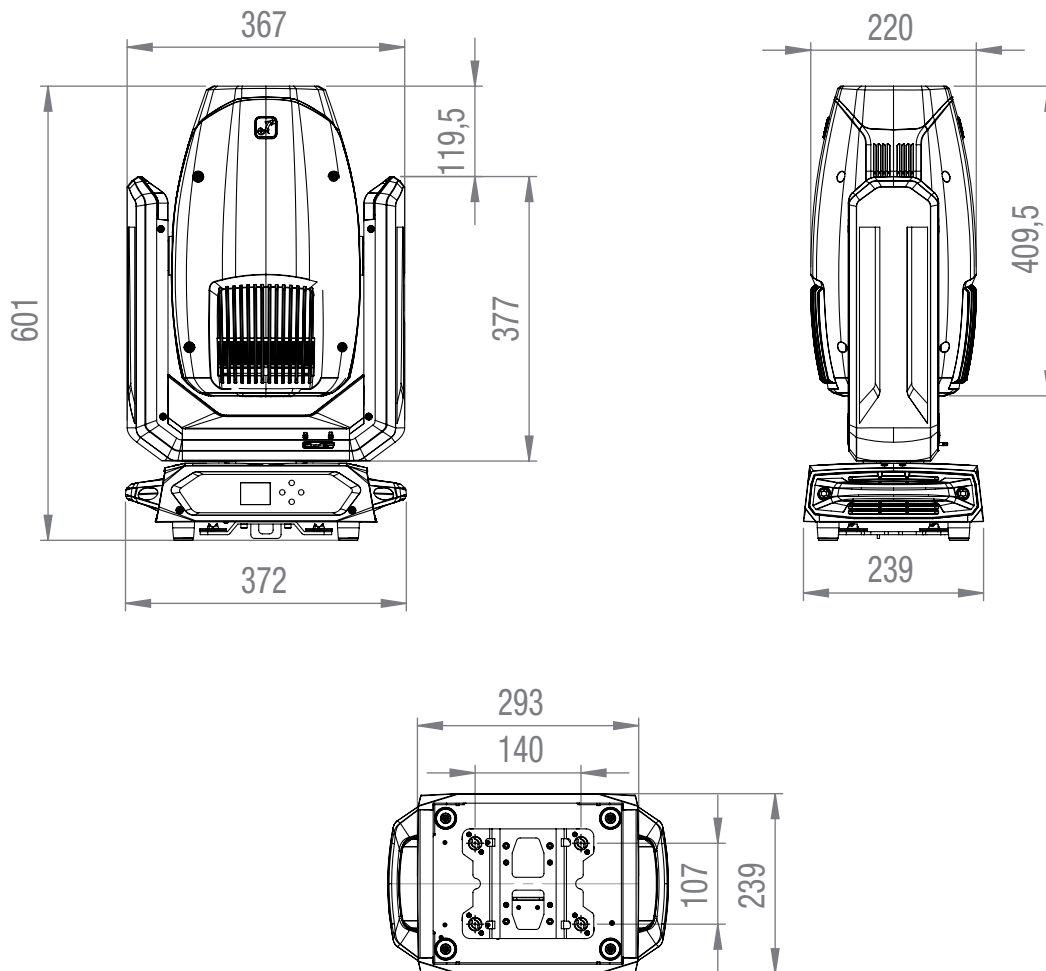

# COLORdash PAR H18X

## FEATURES

- Rugged RGBWA-UV LED wash for events
- Adjustable PWM (Pulse Width Modulation) to avoid flickering on camera
- RDM (Remote Device Management) for added flexibility
- Selectable, smooth dimming curves for eliminate flicker and choppiness in fades
- Easy to read OLED display with password protection and touchscreen interface
- Advanced optics provide exceptional color mixing and high efficiency
- Double-bracketed yoke with omega bracket doubles as floor stand



## SPECIFICATIONS

### OPTICAL

- Light Source: 18 LEDs (HEX-color RGBWAUV) 150 W, (550 mA), 50,000 hours life expectancy.
- Color Temperature (range): 2800 to 10,000K
- Color Temperature (at full): 9507K
- Beam Angle: 23.6°
- Field Angle: 38.6°
- Lumens: 5,736
- Illuminance: 1,207 lux @ 5 m
- Selectable PWM: 600 Hz, 1200 Hz, 2000 Hz, 4000 Hz, 6000 Hz, 25,000 Hz

### DYNAMIC EFFECTS

- Dimmer: Electronic
- Shutter/Strobe: Electronic
- Strobe Rate: 0 to 20 Hz
- Standalone Color Mixing: Yes
- Color Temperature Presets: Yes
- Dim Modes: 4
- Built-in Automated Programs: Yes

### CONSTRUCTION / PHYSICAL

- Dimensions: 12.45 x 4.38 x 8.68 in (316.4 x 111.5 x 220.7 mm)
- Weight: 10.4 lb (4.7 kg)
- Exterior Color: Black
- Housing Material: Aluminum die-cast
- Accessory Holder/Gel Frame Size: 9.25 in (235 mm)

### CONNECTIONS

- Power Connection: Edison (local) plug to Seetronic Powerkon IP65
- Power Input: Seetronic Powerkon IP65
- Power Output: Seetronic Powerkon IP65
- Data Connectors: 3- and 5-pin XLR
- Cable Length (power): 5 ft (1.5 m)

### CONTROL

- Control Protocol: DMX, RDM
- DMX Channels: 6, 8, 9, 13 or 14

- Modes/Personalities: 3 personalities (6ch, 8ch, 9ch, 13ch, 14ch)

## **ELECTRICAL**

- Input Voltage: 100 to 240 VAC, 50/60 Hz (auto-ranging)
- Power Linking: 9 units @ 120 V; 15 units @ 208 V; 17 units @ 230 V
- Power and Current: 155 W, 1.305 A @ 120 V, 60 Hz
- Power and Current: 153 W, 0.773 A @ 208 V, 60 Hz
- Power and Current: 152 W, 0.704 A @ 230 V, 50 Hz

## **CERTIFICATIONS / QUALIFICATIONS**

- CE, MET, FCC, UKCA
- IP Rating: IP20, dry location
- Temperature (Ambient): -4 °F to 113 °F (-20 °C to 45 °C)

## **WHAT'S INCLUDED**

- COLORdash PAR H18X
- Seetronic Powerkon IP65 power cord
- Gel frame holder
- Omega bracket
- Quick Reference Guide or User Manual

## **OPTIONAL ACCESSORIES**

- Professional Clamps: CTC-50HC, CTC-50HCN
- Neutrik® powerCON® cables
- 3- or 5-pin DMX Cables
- Barndoor

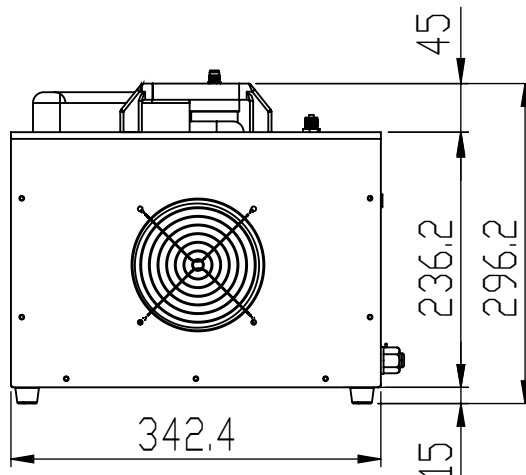
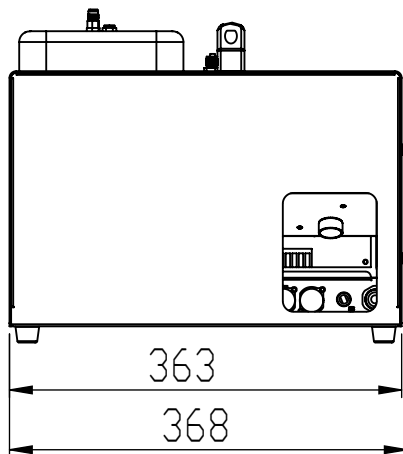
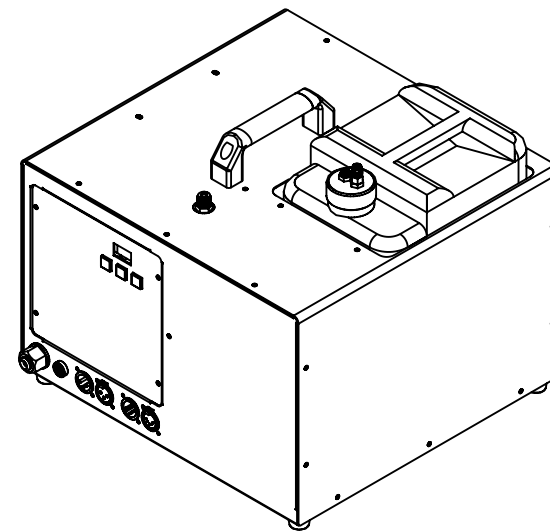
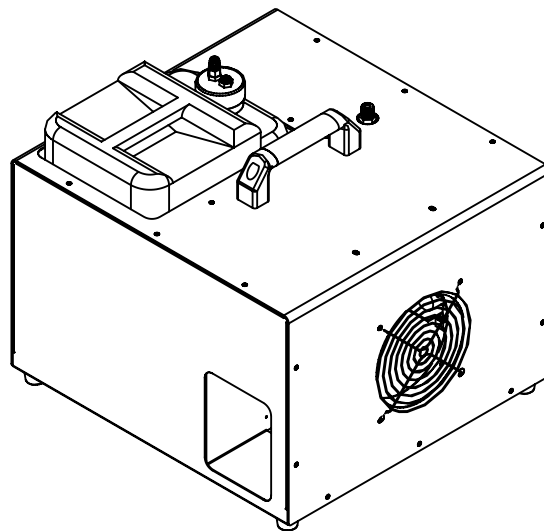
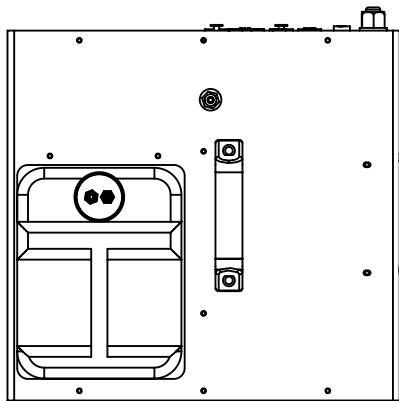

# CLIH1400PRO INSTANT HAZER 1400 PRO



Adam Hall GmbH - Daimlerstraße 9 - D-61267 Neu-Anspach - Germany

Telefon +49 (0) 6081 / 94 19-0 - Fax +49 (0) 6081 / 94 19-1000 - [www.adamhall.com](http://www.adamhall.com)

## AC Relay Accessory

MODEL PS-REL (FOR USE WITH PS-8R, PS-PRO, POWERPORT AND MINIPOINTS)

## Instruction Sheet

### About the PS-REL

The PS-REL AC Relay Accessory is designed primarily for use with the PS-8R 15 amp Power Sequencer, the PS-PRO 20 amp Power Sequencer, the PowerPort 20 amp Remote AC Controller, the MiniPort-30 Power Relay (30 amps), MiniPort-20 Power Relay (rated 20 amps), and the MiniPort-15 Power Relay (rated 15 amps).

The PS-REL is simply a small box containing a relay. It functions as a sensor which can close a switch in response to the presence of AC power.

The PS-REL is needed whenever a PS-8R, PS-PRO, PowerPort or MiniPort (or linked chain of PowerPorts or MiniPorts) must be turned on in response to energizing a switched outlet. This occurs frequently in "home theater" installations when a switched outlet on a preamp or receiver, often activated by a wireless remote device, is to be used to power up a large amount of equipment. It allows multiple 15-amp and 20-amp circuits to be controlled from one device.

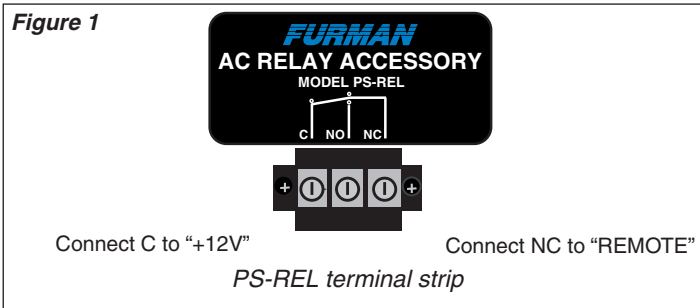

The PS-REL has a two-prong AC plug on a 6-foot cord to activate the relay, and three terminals that connect to the relay contacts (Fig. 1). There is a common contact labeled (C), a normally open contact (NO), and a normally closed contact (NC). It should be noted that when connecting the PS-REL to any Furman sequenced power product that (C) should be connected to the (+12V) terminal, and that (NC) should be connected to the (REM) terminal.

When the relay opens, the device will turn on. Two wires should be connected to the +12V and REM IN screw terminals of the PS-8R, PS-PRO, PowerPort, or MiniPorts. The PS-REL's AC cord should be plugged into the outlet to be sensed.

The PS-REL AC Relay Accessory may also be used: (1) To allow a PS-8R or PS-PRO to be hooked up to another PS-8R or PS-PRO to provide six separate delayed turn on/turn off groups, by having the relay sense the presence of power at the Delay 3 outlet, (2) To turn on a single PowerPort or a chain of PowerPorts linked together; (3) To turn on a MiniPort or a chain of MiniPorts linked together.

When AC power appears at the sensed outlet, the PS-8R, PS-PRO, PowerPort (or linked chain of PowerPorts), or MiniPort (or linked chain of MiniPorts) will begin its turn-on sequence.

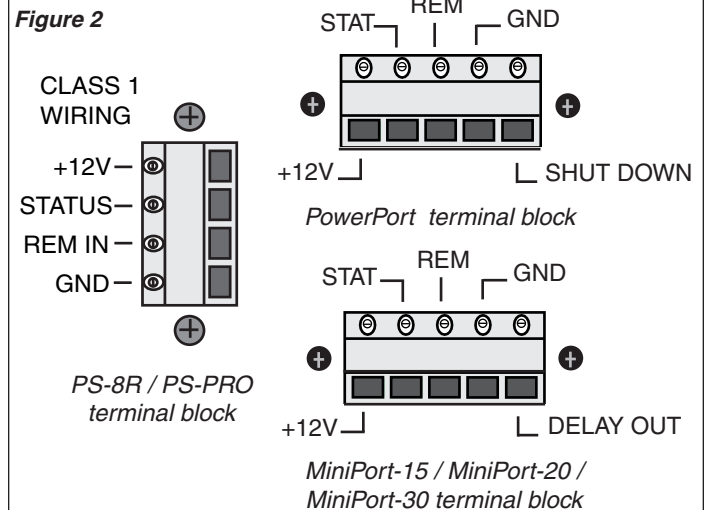

### Limited Warranty

The Furman PS-REL is warranted against failures due to defective parts or faulty workmanship for a period of three years after delivery to the original owner. During this period, Furman will make any necessary repairs without charge for parts or labor. Shipping charges to the factory or repair station must be prepaid by the owner; return shipping charges (via UPS Ground) will be paid by Furman.

This warranty applies only to the original owner and is not transferable. Also, it does not apply to repairs done other than by the Furman factory or Authorized Repair Stations.

This warranty may be cancelled by Furman at its sole discretion if the PS-REL unit has been subjected to physical abuse or has been modified in any way without written authorization from Furman. Furman's liability under this warranty is limited to repair or replacement of the defective unit.

Furman will not be responsible for incidental or consequential damage resulting from the use or misuse of its products. Some states do not allow the exclusion of incidental or consequential damages, so the above limitations may not apply to you. This warranty gives you specific legal rights, and you may also have other rights which vary from state to state.

Warranty claims should be accompanied by a copy of the original purchase invoice showing the purchase date (if a Warranty Registration Card was mailed in at the time of purchase, this is not necessary). Before returning any equipment for repair, please read the important information on service, which follows.

### Service

Before returning any equipment for repair, please be sure that it is adequately packed and cushioned against damage in shipment, and that it is insured. We suggest that you save the original packaging and use it to ship the product for servicing. Also, please enclose a note giving your name, address, phone number and a description of the problem.

NOTE: All equipment being returned for repair must have a Return Authorization (R/A) Number. To get an R/A Number, please call the Furman Service Department, (707) 763-1010, ext. 121, between 8 am and 5 pm U.S. Pacific Time. Please display your R/A Number prominently on the front of all packages.

Contact us for More Information

We'll send you our full-line color catalog and a detailed data sheet on any Furman product. And be sure to visit our website at <http://www.furmansound.com>

# CN-1800S & CN-2400S

## Contractor Series SmartSequencers



Furman's SmartSequencers combines AC power distribution, protection, filtration, and sequential system power on/off in a 1RU, 120VAC, rack-mount unit.

### Features

- SmartSequencing technology allows large and complex A/V systems to be safely powered on and off with a simple press of a button or turn of a key, even by non-technical personnel.
- Multiple units may be daisy chained at runs of over 1,000' between units with bi-directional communications between units for sequencing on and off large and/or complex systems.
- RS-232 compatibility and command set provide integration with control systems, optional RS-232-to-Ethernet adaptor allows for control, programming, & monitoring from any Web-enabled device via Telnet, direct HTTP connection, or Panamax/Furman's BlueBOLT® platform.
- Series Multi-Stage Protection (SMP) ensures zero downtime for mission-critical installations by safely absorbing, clamping and dissipating transient surges and spikes without damage to internal circuitry or connected equipment.
- Extreme Voltage Shutdown (EVS) safeguards from catastrophic under-voltage (under 80V sustained) or over-voltage (over 145V sustained) conditions. Circuit may be set to auto-reset when voltage returns to normal or manual reset after an event is detected.
- Linear Filtering Technology (LiFT) ensures maximum performance from connected equipment by reducing AC noise evenly across the audio & video bandwidth.
- Security covers and sequence on/off keyswitch prevent unauthorized personnel from running/shutting down system or tampering with DIP switches.
- Fire alarm shut off.
- Available with 15 amp capacity (CN-1800S) or 20 amp capacity (CN-2400S).
- 15 Year Limited Product Warranty. See warranty policy documentation for terms and conditions.



### Front Panel

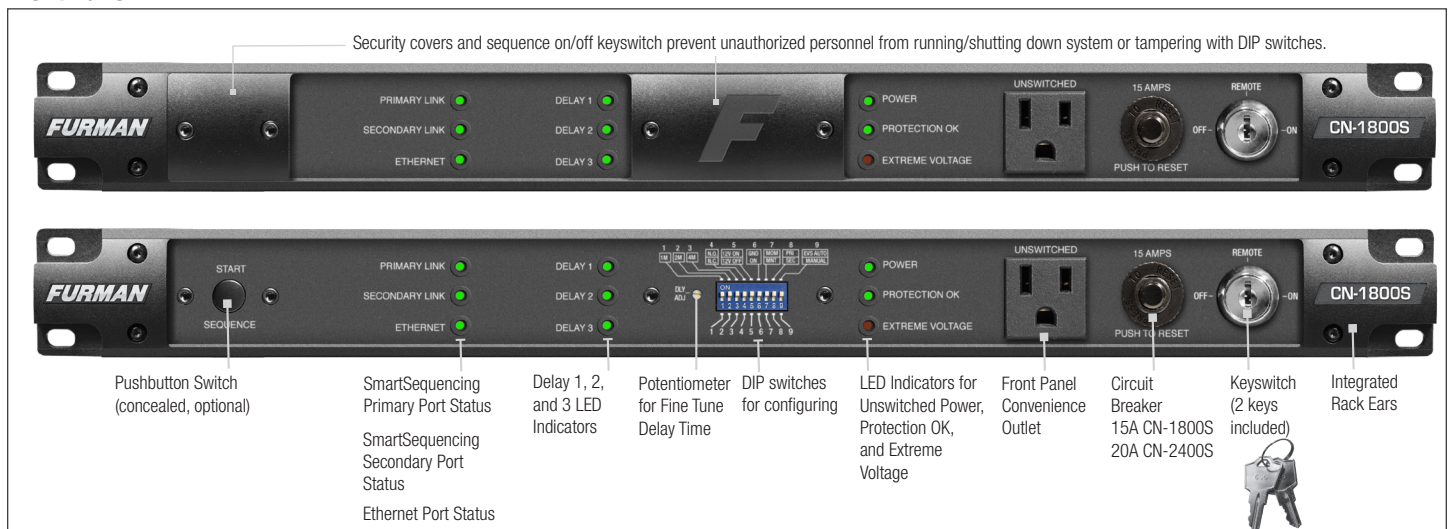

# CN-1800S & CN-2400S Contractor Series SmartSequencers

## Rear Panel

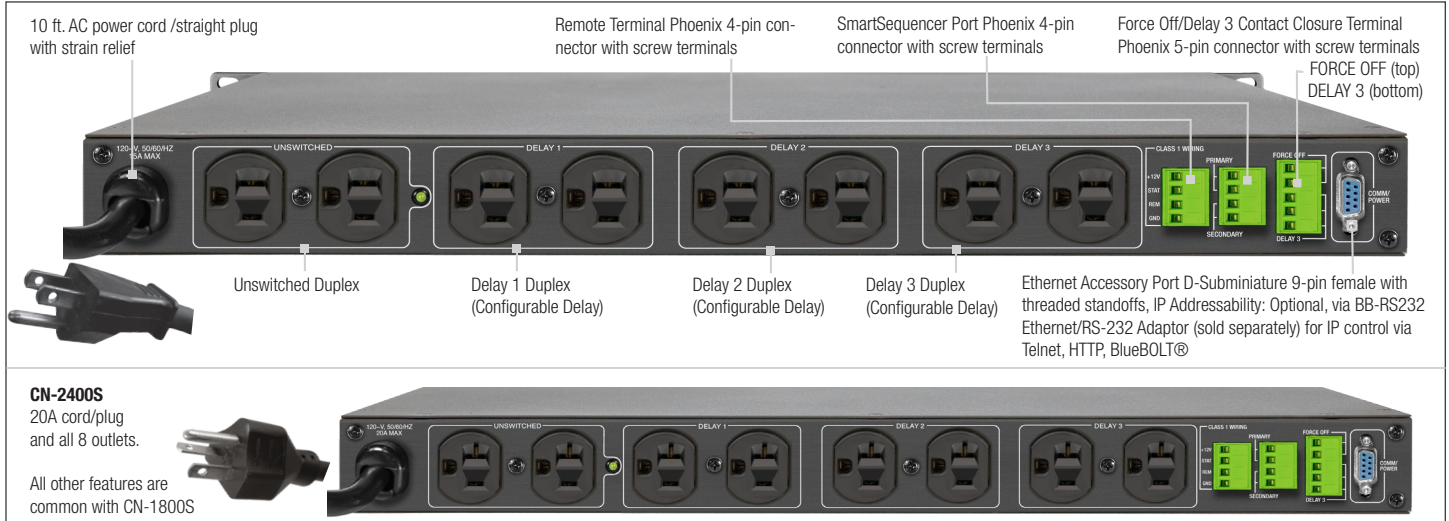

## Specifications

### AC Voltage Input Range

90-139VAC, 50/60Hz

### Maximum AC Current Rating

CN-1800S: 15 amps (Thermal breaker)  
CN-2400S: 20 amps (Thermal breaker)

### AC Cord:

CN-1800S: 3/14AWG, 10 feet, black, fixed, NEMA 5-15P plug  
CN-2400S: 3/12 AWG, 10 feet, black, fixed, NEMA 5-20P plug

### AC Receptacles:

Convenience Outlet (Front Panel) 1 Unswitched NEMA 5-15R  
CN-1800S Rear Panel Outlets: 2 Unswitched NEMA 5 15R's (1 duplex),  
6 Sequenced NEMA 5-15R's (3 duplexes each controlled by separate relay)  
CN-2400S Rear Panel Outlets: 2 Unswitched NEMA 5 20R's (1 duplex),  
6 Sequenced NEMA 5-20R's (3 duplexes each controlled by separate relay)

### Surge/Under-Overvoltage Protection:

AC Surge Protection: SMP  
Spike Protection Mode: Line to neutral, zero ground leakage  
Spike Clamping Voltage: 188VAC peak @ 6,000 volts/3,000 amps  
Response Time: 1 nanosecond  
Maximum Surge Current: 6,500 Amps  
AC Undervoltage Protection: EVS, 77VAC+/- 3VAC  
AC Overvoltage Protection: EVS, 145VAC+/- 5VAC  
AC Overvoltage Reset Modes: Manual and Auto-reset (configurable)

### AC Filtering:

LI FT  
Noise Attenuation: Linear, 10dB @10KHz, 40dB@100KHz, 50dB@500KHz

### Operating Temperature Range:

5C (40F) to 40C (105F) degrees

### Humidity Range:

<90% rH (Relative Humidity)

### User Interface:

Keyswitch: Front panel, 3-position keyswitch (On, Off, Remote)  
Keys: Included, 1 pair  
Pushbutton Switch: Front panel, hidden by security cover  
Circuit Breaker: Front panel, pushbutton, 15A (CN-1800S), 20A (CN-2400S) Thermal Breaker  
Front panel diagnostic indicators: Primary link, Secondary link, Ethernet, Remote off, Delay 1, Delay 2, Delay 3, Power, Protection OK, Extreme Voltage  
Front Panel DIP Switches: Front panel, hidden by security cover, 1 Minute Delay, 2 Minute Delay, 4 Minute Delay,  
Force Off NO/NC, 12V Mode On/Off GND Mode On, Momentary/Maintained, Primary/Secondary, EVS Reset Auto/Manual  
Potentiometer: Front panel, hidden by security cover, fine tune delay adjust

### Control/Status/Triggering (Rear Panel):

Remote Terminal: +5-30VDC In, 12VDC (12mA) Out  
SmartSequencing: Phoenix 4-Pin Connector, Screw Terminals, Primary & Secondary Links (Current Loop - 1000' nominal)  
Remote Terminal: Phoenix 4-Pin Connector With Screw Terminals; +12V, STAT, REM, GND (Class 2 Wiring)  
Force Off/Delay 3 Terminal: Phoenix 5-Pin Connector With Screw Terminals, FORCE OFF, DELAY 3 (Class 2 Wiring)  
RS-232 Compatible: Yes, DB-9 Connector  
IP Addressability: Optional, via BB-RS232 Ethernet/RS-232 Adaptor (sold separately) for IP control via Telnet, HTTP, BlueBOLT®  
Voltmeter: Available with RS-232/Ethernet option, +/- 2VAC accuracy  
Ammeter: Available with RS-232/Ethernet option, +/-1A accuracy

### Power Consumption (No Load): 10 Watts

### Safety Agency: NRTL-C

### RoHS Compliant: Yes



Specifications subject to change due to product upgrades and improvements.

## Dimensions and Weight

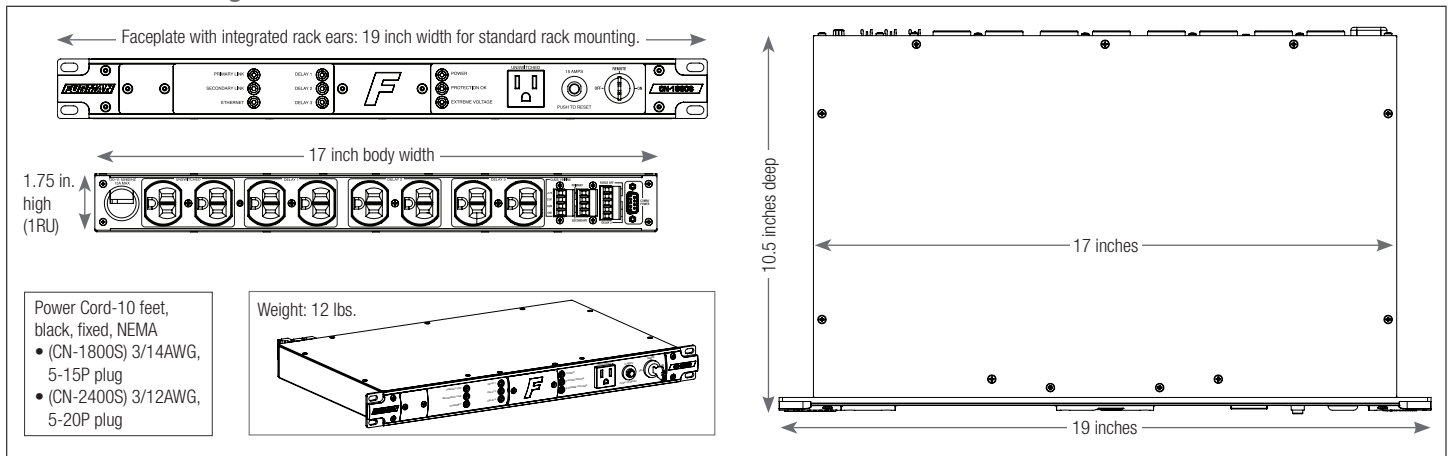



# CN-15MP & CN-20MP

Contractor Series MiniPorts



**CN-15MP**  
(shown without Phoenix-type connectors and security cover)



**CN-20MP**  
(shown with Phoenix-type connectors and security cover)

## Features

- Provides AC control for equipment located away from system racks with primary power conditioners/sequencers (i.e. powered speakers).
- Sequencing of duplex initiated remotely by standard analog triggering (remote terminal) or digital link (SmartSequencing from CN-1800S or CN-2400S).
- SmartSequencing Technology allows multiple units to be daisy chained at runs of over 1,000' between units with bi-directional communications between units for sequencing on and off large and/or complex systems.
- IP Control (Telnet or cloud-based BlueBOLT) via SmartSequencing (when connected to CN-1800S/ CN-2400S with BB-RS232 Adaptor).
- Remote terminal supports connections to legacy Furman (non-Contractor Series) and third party power sequencers for maximum installation flexibility.
- DIP switches and potentiometer allows customization of settings such as sequencing delays, 12V on/off, and more.
- Extreme Voltage Shutdown (EVS) safeguards from catastrophic under-voltage (under 80V sustained) or over-voltage (over 145V sustained) conditions. Circuit may be set to auto-reset when voltage returns to normal or manual reset after an event is detected.
- Security covers prevent unauthorized personnel from tampering with DIP switches.
- Fire alarm shut off.
- Available with 15 amp capacity (**CN-15MP**) or 20 amp capacity (**CN-20MP**).
- Safety agency listed (CSA).
- 15 Year Limited Product Warranty. See warranty policy documentation for terms and conditions.



- Potentiometer for Fine Tune Delay Time
- DIP switches for configuring settings
- Bypass switch overrides relay for troubleshooting or in event of control system failure

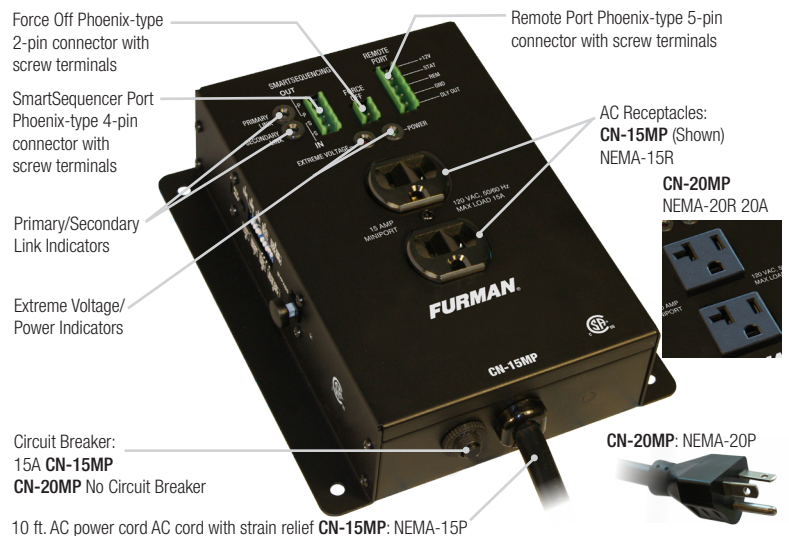

## Specifications

### AC Voltage Input Range

90-139VAC, 50/60Hz

### Maximum AC Current Rating

**CN-15MP:** 15 Amps (Thermal breaker)

**CN-20MP:** 20 Amps

### AC Cord:

**CN-15MP:** 3/14AWG, 10 feet, black, fixed, NEMA 5-15P plug

**CN-20MP:** 3/12 AWG, 10 feet, black, fixed, NEMA 5-20P plug

### AC Receptacles:

**CN-15MP:** 2 NEMA 5-15R's (1 duplex)

**CN-20MP:** 2 NEMA 5-20R's (1 duplex)

### Under-Overvoltage Protection:

AC Undervoltage Protection: EVS, 77VAC+/-3VAC

AC Overvoltage Protection: EVS, 140VAC+/-5VAC

EVS Enable/Disable (configurable)

### Operating Temperature Range:

5C (40F) to 40C (105F) degrees

### Humidity Range:

<90% rH (Relative Humidity)

### User Interface:

Circuit Breaker: Pushbutton, 15A (**CN-15MP**),

20A (**CN-20MP**) No Breaker

Front panel diagnostic indicators (LED): Power, Extreme Voltage, Primary Link, Secondary Link

### User Interface (continued):

Side Panel DIP Switches: Side panel, hidden by security cover, 1 Minute Delay, 2 Minute Delay, 4 Minute Delay, Force Off NO/NC, 12V Mode On/Off GND Mode On, Momentary/Maintained, Primary/Secondary, EVS Reset Auto/Manual  
 Potentiometer: Side panel, hidden by security cover, fine tune delay adjust

### Control/Status/Triggering (Top Panel):

Remote Terminal: +5-30VDC In, 12VDC (12mA) Out

SmartSequencing: Phoenix 4-Pin Connector, Screw Terminals, Primary & Secondary Links (Current Loop - 1000' nominal)

Remote Terminal: Phoenix 5-Pin Connector With Screw Terminals;

+12V, STAT, REM, GND, DLY OUT(Class 2 Wiring)

Force Off: Phoenix-type 2-Pin Connector With Screw Terminals,

FORCE OFF: (Class 2 Wiring)

IP Addressability: Optional, via CN-1800S or CN-2400S with BB-RS232

Ethernet/RS-232

Adaptor (sold separately) for IP control via Telnet, HTTP, BlueBOLT®

Voltmeter: Available via SmartSequencing communication, +/- 2VAC accuracy

Ammeter: Available via SmartSequencing communication, +/-1A accuracy

### Power Consumption (No Load): 10 Watts

### Safety Agency: CSA

### RoHS Compliant: Yes



Specifications subject to change due to product upgrades and improvements.

## Dimensions and Weight

Common FRONT dimensions for both **CN-15MP** and **CN-20MP**

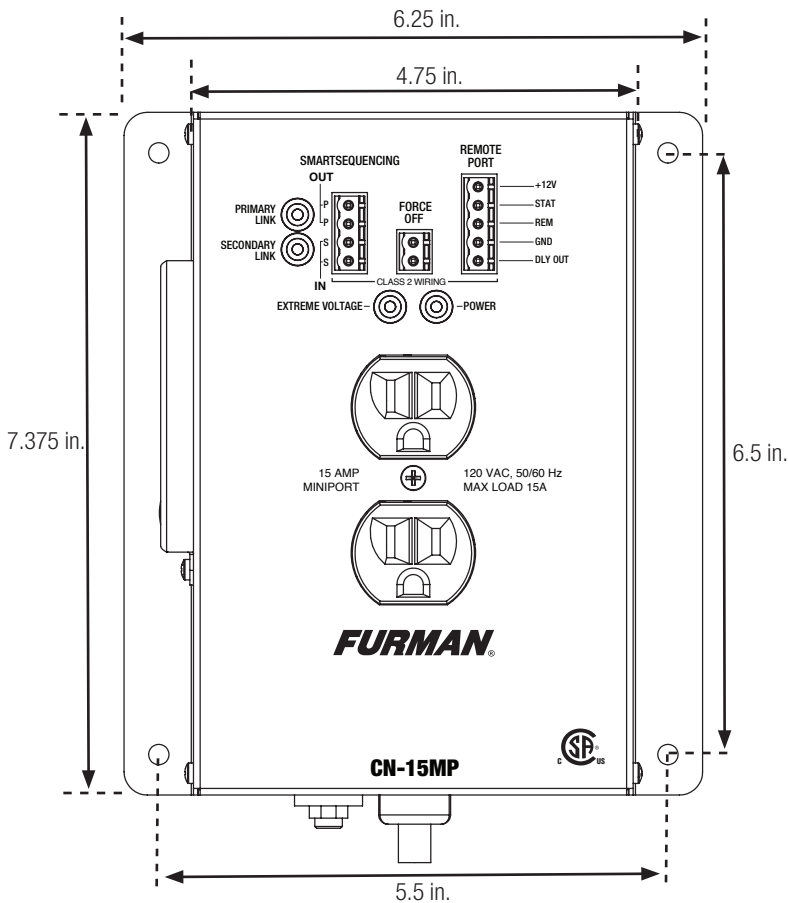

Unit Weight: 3.75 lbs. (both models)

SIDE **CN-15MP**

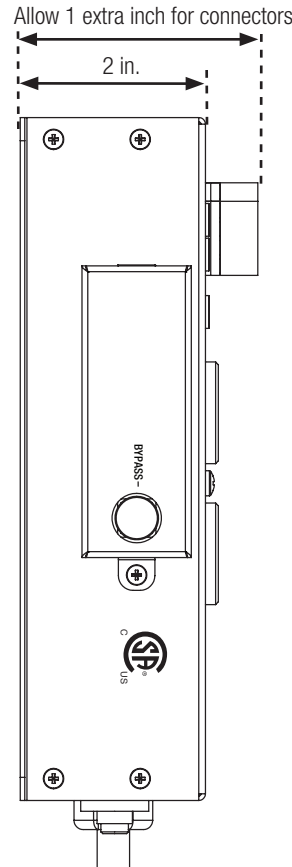

Power Cord-10 feet, black, fixed, NEMA  
 • (CN-15MP) 3/14AWG, 5-15P plug

SIDE **CN-20MP**

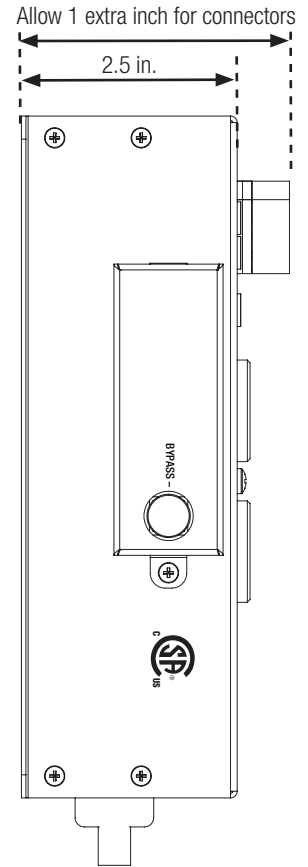

Power Cord-10 feet, black, fixed, NEMA  
 • (CN-20MP) 3/12AWG, 5-20P plug

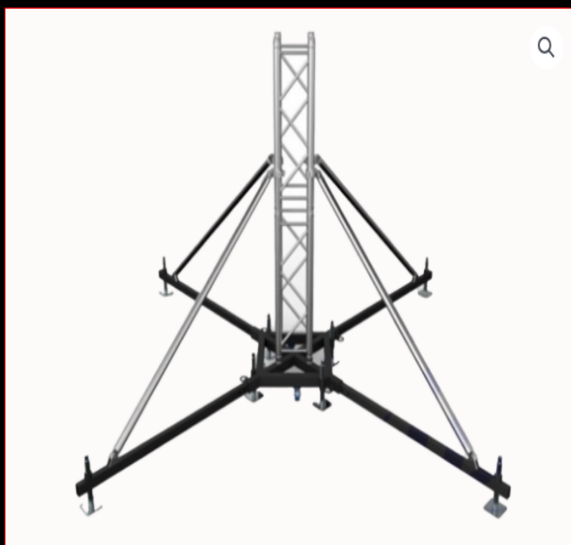

# Truss Ground Support System

SKU: N/A

Categories: G-Truss, Spigot Truss

Tag: G-Truss

The Truss Ground Support System is a heavy duty, full package rigging system that is perfect for flying medium to heavy truss setups. The package comes with everything you need (except the hoist) for 1 complete leg setup. Typically you would use a system like this for building a Truss goal post, or a roofing system. Whether it's for Outdoor or Indoor use, this system makes it convenient to elevate a truss that has heavy loads on it and stabilizing it for your setup.

**Color Options:** Silver or Black (Powder Coated)

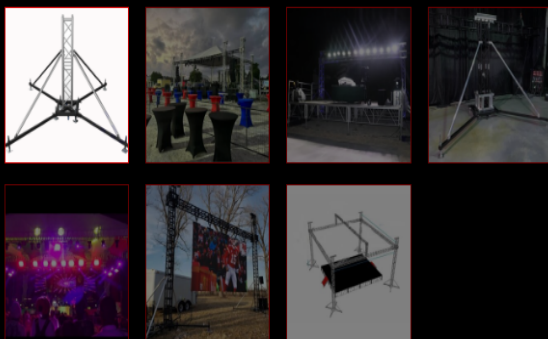

Description

Additional information

Load Chart

Technical Data

Reviews (0)

## Package Includes:

- (1) Steel Base
- (4) Outrigger Legs
- (1) Elevator Block
- (1) Top Section for Hoist
- (1) Hinge Truss 1m

## Color Options:

- Silver or black



# AUDIO TECHNICAL SPECIFICATIONS



# GTX 10

## TWO-WAY LINE ARRAY MODULE



**Description** The GTX 10 is a 2-way line array module for medium to large-scale, high-demanding touring and install applications, indoors and outdoors. Equipped with three best-in-class transducers, it offers excellent reproduction quality and optimized directivity. Up to 24 GTX 10 modules can be suspended on a single fly-bar.

- Features**
- › 143 dB max SPL
  - › 1 x 4" titanium dome, neo compression driver
  - › 2 x 10" neo woofers, 3" v.c.
  - › 110° x 15° 4PATH waveguide
  - › Designed to operate with XPS 16K amplifier (up to 6 modules per amp unit)
  - › Durable and lightweight cabinet construction, polyurea coating
  - › Heavy duty, powder coated, custom perforated front grille
  - › 3 x P-COM 8 pole bayonet connectors (Gold coated, CA-COM compatible, IP 68)

**Part Number** 13000796 GTX 10 Black EAN 8024530021153



# GTX 10

## TWO-WAY LINE ARRAY MODULE

<b>Acoustical specifications</b>	Frequency Response (-10dB)	42 Hz ÷ 20000 Hz
	Max SPL @ 1m	143 dB
	Horizontal coverage angle	110°
	Vertical coverage angle	15°
<b>Power section</b>	Amplification	Bi-Amp
	Nominal Impedance LF	8 ohm
	Nominal Impedance HF	8 ohm
<b>Transducers</b>	Compression Driver	1 x 1.4" neo, 4.0" v.c
	Woofer	2 x 10" neo, 3.0" v.c
<b>Input/Output section</b>	Input connectors	P-COM 8POLE
	Output connectors	P-COM 8POLE
<b>Standard compliance</b>	Safety agency	CE compliant
<b>Physical specifications</b>	Cabinet/Case Material	Birch plywood
	Hardware	Array fittings
	Handles	1 x side, 2 rear
	Grille	Steel with clothing
	Color	Black
<b>Size</b>	Height	337 mm / 13.27 inches
	Width	750 mm / 29.53 inches
	Depth	483.5 mm / 19.04 inches
	Weight	31.5 kg / 69.45 lbs

Line Art 2D

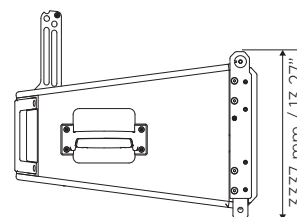
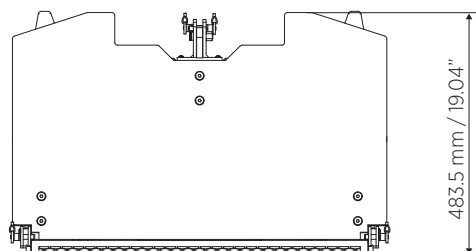
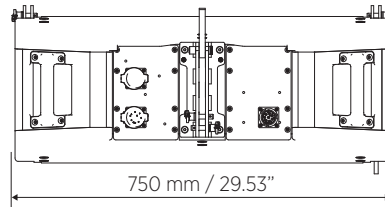
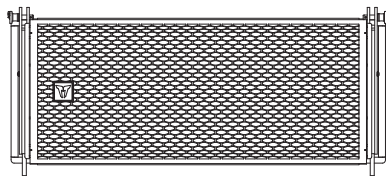



# S 29

## HIGH-POWER BASS REFLEX SUBWOOFER

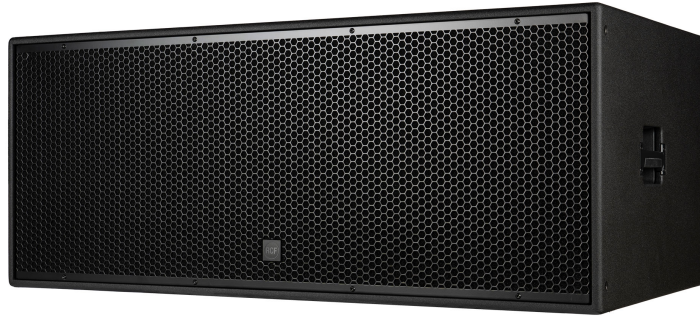

### Description

S 29 is a high-power double 19" subwoofer suitable for RCF Installed Sound systems. The bass-reflex design ensures an efficient acoustic response down to 25 Hz. The high-quality plywood cabinet is finished with a black, heavy-duty polyurea coating and protected by a powder-coated metal grille. The recessed input panel features two Speakon NL4 connectors, allowing a quick and safe connection. A M20 pole mount adaptor on top and handles on both sides are provided. Both models can be ground-stacked and are cardioid-arrayable for improved rear rejection.

### Features

- › Up to 3000 W power handling
- › 143 dB max SPL
- › 25 ÷ 200 Hz frequency range
- › 2x19" HyperVented Neodymium Woofer with 4" v.c.
- › High-quality polyurea-coated multi-ply cabinet
- › Steel front grille with clothing
- › M20 standard pole mount in top section of cabinet
- › Speakon NL4 connectors

### Part Number

13100097 S 29

EAN 8024530021757





# S 29

## HIGH-POWER BASS REFLEX SUBWOOFER

Line Art 2D

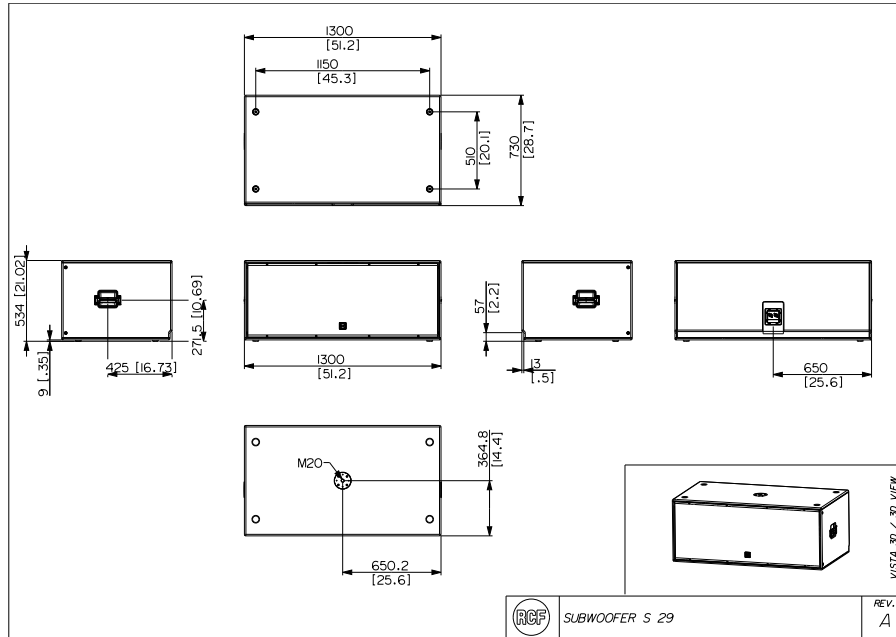

### TECHNICAL SPECIFICATIONS

<b>Acoustical specifications</b>	Frequency Response (-10dB)	25 Hz ÷ 200 Hz
	Max SPL @ 1m	143 dB
<b>Power section</b>	Amplification	Full Range
	Nominal Impedance	4 ohm
	Power Handling	3000 W
	Peak Power Handling	12000 W PEAK
<b>Transducers</b>	Woofers	2 x 19" neo, 4.0" v.c
<b>Input/Output section</b>	Input connectors	Speakon® NL4
	Output connectors	Speakon® NL4
<b>Standard compliance</b>	Safety agency	CE compliant
<b>Physical specifications</b>	Cabinet/Case Material	Plywood
	Handles	2 side
	Pole mount/Cap	Yes
	Grille	Steel with clothing
<b>Size</b>	Height	534 mm / 21.02 inches
	Width	1300 mm / 51.18 inches
	Depth	730 mm / 28.74 inches
	Weight	85 kg / 187.39 lbs



# FL-B HDL 6

FLY BAR



### Description

Flybar for HDL 6-A; HDL 12-AS; HDL 26-A; HDL 35-AS + 1x Pickup Tab with Shackle + Stacking Bar + Pole Mount + M20 Adapter. Pins included.

### Standard compliance

Safety agency

CE compliant

### Size

Weight

7.48 kg / 16.49 lbs

### Physical specifications

Color

Black, White

### Line Art 2D

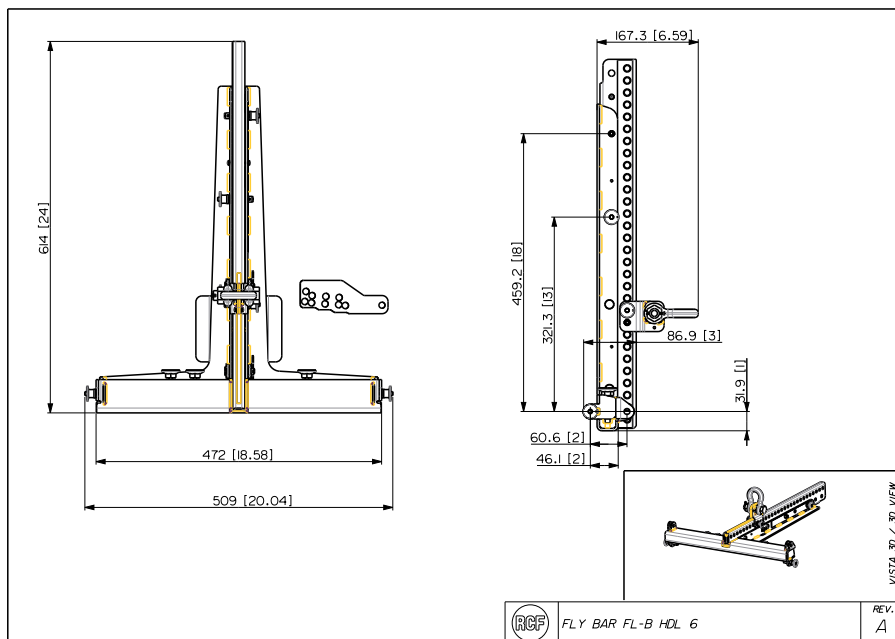

### Part Number

13360360 FL-B HDL 6  
13360373 FL-B HDL 6 W

Black  
White

EAN 8024530014209  
EAN 8024530014377

### Technical Specifications

Products are continually improved. All specifications are therefore subject to change without notice.



# XPS 16KD

## DANTE-EQUIPPED 4-CHANNEL DSP POWER AMPLIFIER



### Description

XPS 16KD is a four-channel power amplifier with advanced processing and advanced routing with Dante, digital and analog I/O for both touring and install use. With 4x4000 W Class D continuous power at 2.7 ohms, 40-bit floating-point processing at 96 kHz, and 32-bit internal routing, XPS 16K packs extreme power density in a 2U chassis.

Designed for both touring and installed sound systems, XPS is intended for use with high-performance speakers and provides ready-to-use configurations and presets. It can also be used in linear mode with advanced tuning capabilities.

Each output features: 4000 ms output delay (1372 m / 4501 ft), EQ Filters, Crossovers, FIR Filters, Multiband Compressor, RMS Limiter, and Thermal limiter.

XPS delivers rider-friendly premium sound with full RNet remote management, large touch interface onboard, exceptional signal/noise ratio, ultra-low distortion, and extreme dynamic range.

### Features

- › 16000 W Total Continuous Power
- › 40-bit Floating-point DSP and 32-bit routing up to 96 kHz
- › Dante Audio Network
- › FIRPHASE, Bass Motion Control, Bass Shaper
- › RNet Networked Management
- › Touch 4.3" Color TFT Interface
- › Full On-board Processing with Delay, EQ, Comp/Limiter
- › On-board Speaker Presets Library
- › Class-D Modules with SMPS and Advanced PFC

### Part Number

12100064	XPS 16KD	EU	90-240 V	Black - RAL 9005	EAN 8024530020125
12100075	XPS 16KD	US	90-240 V	Black - RAL 9005	EAN 8024530020392
12100077	XPS 16KD	UK	90-240 V	Black - RAL 9005	EAN 8024530020859



# XPS 16KD

DANTE-EQUIPPED 4-CHANNEL DSP POWER AMPLIFIER

Line Art 2D

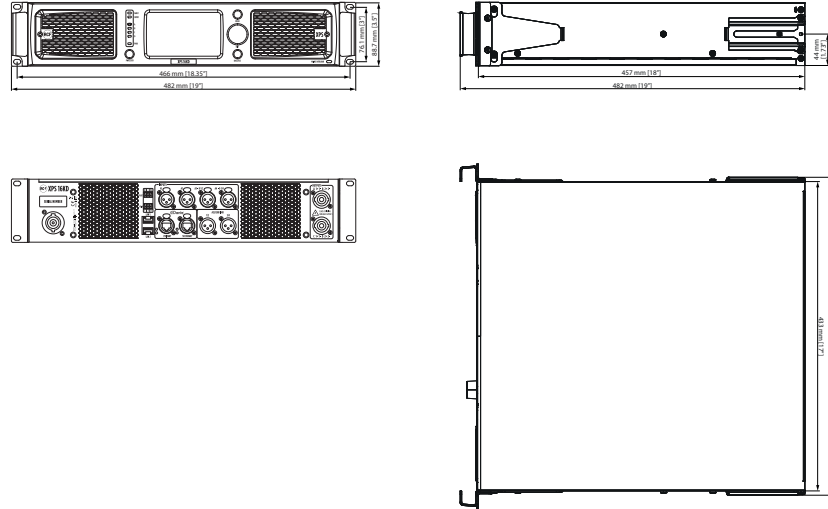

## TECHNICAL SPECIFICATIONS

### Amplifier specifications

Amplifier Class	D
Output Power (EIAJ 8:32 all channels driven)	4 x 4000 W @ 2.7 ohm 4 x 2600 W @ 4 ohm 4 x 1400 W @ 8 ohm
Frequency Response (-3dB)	20 Hz ÷ 23000 Hz
SNR Analog inputs (unweighted)	>111 dB
SNR Digital inputs (unweighted)	>115 dB
Crosstalk	<70 dB
Distortion (THD+N) (20 Hz ÷ 20000 Hz, 1000 W @ 4 ohm)	<0.2 %
Gain (linear mode @ 0 dB)	32 dB
Damping factor (@ 8 ohm, 20 Hz ÷ 1500 Hz)	>95
Max burst length (@ 50 Hz, CF = 7 dB, 4 ohm, 1% THD+N)	200 ms

### Input section

Total number of inputs	16
Line inputs	4
Line connectors	XLR
Digital inputs	12
Digital connectors	Ethercon, XLR
Digital type	AES/EBU, DANTE
General Purpose Inputs (GPI)	2
Programmable GPI	Yes
Photo-coupled GPI	2

### Output section

Signal output number	4
Signal output connectors	XLR
Power output connectors	Speakon
General Purpose Outputs (GPO)	3
Programmable GPO	Yes



# XPS 16KD

## DANTE-EQUIPPED 4-CHANNEL DSP POWER AMPLIFIER

<b>Processing</b>	DSP EQ Filters Advanced algorithms  Compressors Delay Tone controls High-pass filter Crossover Automatic Gain Control (ACG)	Yes Yes FiRPHASE technology   BASS shaper   air compensation   mid-low correction   driver excursion control   dynamic PEQ   multi-band compressor   pilot tone detection   backup recovery strategy   impedance load measurement Yes Yes Yes 10 Hz ÷ 1000 Hz 2500 ÷ 3500 Hz Yes
<b>Configuration and control</b>	Configuration Network RCF speakers presets Priority RDNet	Front panel touch screen, PC Software Gigabit ethernet Yes Yes Yes
<b>Protections</b>	Cooling Short circuit Thermal DC Fuses VHF (Very High Frequencies)	Forced Yes Yes Yes Yes Yes
<b>Operating conditions</b>	Temperature range - Continuous operation Temperature range - Reduced output power Fan noise idle Fan noise max	-5°C ÷ +40°C / +23°F ÷ +104°F -5°C to +50°C / +23°F to +122°F <35 dBA <64 dBA
<b>Power requirement</b>	Operating voltage Nominal current AC @ 100-120 V Nominal current AC @ 220-240 V Stand by power consumption Idle power consumption Power consumption Main fuse Fuses Model	90-240 V- 50/60Hz 30 A 16 A 20 W 90 W 5800 W Internal F 315 mA H 100 V
<b>Standard compliance</b>	Safety agency	CE compliant, UL 62368-1, 3rd Ed. CSA C22.2 No. 62368-1:19, 3rd Ed.
<b>Physical specifications</b>	Cabinet/Case Material Handles Color Rack mounting	Metal 2 metal handles for rack mount Black - RAL 9005 19", 2U
<b>Size</b>	Height Width Depth Weight	88.7 mm / 3.49 inches 482 mm / 18.98 inches 482.4 mm / 18.99 inches 15 kg / 33.07 lbs

# HD96-24-CC-IP



Live Digital Console Control Centre with 144 Input Channels, 123 Mix Buses, 96 kHz Sample Rate and 21" Touch Screen

### Product Features

[Show more](#) ▾

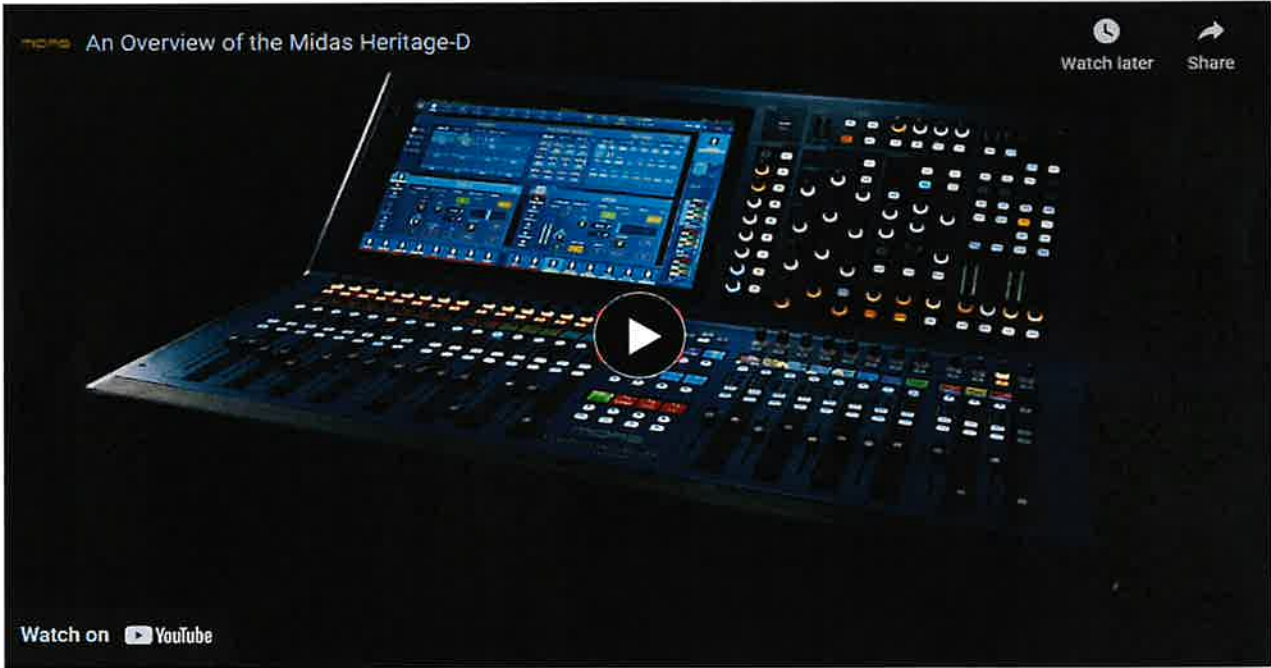

### Heritage History

The Heritage 3000 (H3K) was first introduced in 1999. Its famous purple colour and features made it so distinctly Midas. It soon established itself as the world wide industry standard for live sound applications. The H3K proved to be a huge winner from day one.

The striking colour scheme wasn't the only thing that made waves within the industry. With a new pre-amp design bettering that of the iconic XL4, large channel and aux counts plus the flexible aux switching system, it's no wonder the H3K appeared on everyone's spec as the console of choice.

Living up to the reputation of the H3K is undeniably a hard task; the H3K set a new standard in live mixing.

Naming the Heritage D after such an iconic mixing console was indeed a bold move. However, this product is bold and innovative, and it's



a bold move. However, this product is bold and visionary whilst keeping the legendary sound quality and raising the bar on what a digital mixing console can achieve.

Building on the prolific history of the H3K and PRO Series consoles, the new Heritage D now reinvents the workflow of the sound engineer. Finally, a Midas you can touch. Featuring a powerful 21" HD touch screen and formidable ultramodern Graphic User Interface (GUI) control all at your fingertips. Heritage D is a vision of the future with thought provoking new features such as Channel AI (yes, Artificial Intelligence).

This platform is designed for the future and will continue to grow and develop over many years with an impressive Midas team that are eager to improve and constantly add new features. Your investment in the Heritage D is safe.



## The Graviton Mk 2 Processing Engine

At the heart of every mixing console is the most important part – Audio. Overlooked by other manufacturers, we have always put sound at the top of our priority list.

It was hard, almost impossible, but we improved on the legendary Midas digital sound with our new 64-bit summing mix engine with increased dynamic range. Driving a Midas has never been easier.

The key to the Midas sound is in giving ultimate flexibility while still being delay compensated. Avoiding the dreaded comb filtering effect is so very important. Many other consoles simply ignore this crucial part of the audio signal path.



## Flexi-Aux

The Flexi-Aux system gives the ability to send aux to aux for group or stem style mixing. Now you can smash a whole drum kit with parallel compression and feed it to an artists in ear mix.

[Show more](#) ▾

Specification

[Show less](#) ▾

## Processing

Input processing channels	144 flexi channels
Output processing channels	96 flexi aux outputs, 24 matrices, stereo bus, mono bus
Point-to-point routing matrix	622 x 652
Signal processing	64-bit floating point
D/A converter	24-bit, 96 kHz and 128 times oversampling
A/D converter	24-bit, 96 kHz and 128 times oversampling
Sampling frequency	96 kHz
I/O latency (surface input to output)	1.34 ms
Input audio processing	<ul style="list-style-type: none"> <li>Dual-slope high and low-pass filters</li> <li>True phase filter control</li> <li>4-band parametric EQ with 3 shelf modes</li> <li>4-mode creative input compressors</li> <li>Input gates or ducker</li> <li>Insert point on/off with processing order change</li> <li>Direct output with adjustable level and processing pick of point</li> <li>Delay-compensated aux return mode on inputs</li> <li>5 x tap-off points per send</li> </ul>
Output audio processing	<ul style="list-style-type: none"> <li>Output 4-band parametric EQ with shelving/HP/LP options</li> <li>4-mode creative output dynamics</li> <li>Insert point on/off with processing order change</li> <li>Direct input with adjustable level and processing tap-off point</li> </ul>
Mixing control assistance	<ul style="list-style-type: none"> <li>12 x talk groups</li> <li>12 x mute groups</li> <li>24 x surface POPulation groups</li> <li>24 x VCA associated population groups</li> <li>Scene snapshot automation</li> </ul>
<b>Connectors</b>	
Midas microphone preamplifier	8 x XLR balanced
Balanced outputs	8 x XLR balanced
Talkback connector	1 x XLR balanced
Talk connector	1 x XLR balanced
Headphones connector	5 x 1/8" TRS (stereo)



Headphone connector	2 x ¼" HS (stereo)
Digital AES3 input / output (XLR)	2 / 2
AES50 ports (Klark Teknik SuperMAC, 100 Mbit/s)	4
Snake (copper)	2 x HyperMac (192 channels of bi-directional digital audio) on Ethercon XLR
Snake (fibre)	2 x HyperMac (192 channels of bi-directional digital audio) on Opticon XLR
CM1 expansion slots	2 x slots (CM1 module for AES50, DANTE, MADI and USB)
Ultranet	2 x Ultranet ports (up to 16 digital outputs per port)
Word clock IN	BNC, accepts TTL level, 96 kHz square wave, impedance 75 Ohms
Word clock OUT	BNC, provides a TTL level, 96 kHz square wave
AES3 sync IN	1 x 3-pin XLR
AES3 sync OUT	1 x 3-pin XLR
External (Ethernet) connector	Ethercon XLR
Monitor output	2 x HDMI (1920 x 1080p 59.94Hz/60Hz 16:9 & 720 x 480p 59.94Hz/60Hz 16:9 supported)
USB 3.0 type A hub	4 x 5 V = 900 mA
USB 3.0 type A (fader port expansion)	4 x 5 V = 900 mA
USB 2.0 type A (front surface data)	1 x 5 V = 500 mA
Diagnostics Port	Serial port
MIDI	In, Out and Thru 5-pin MIDI DIN sockets
Lamp	2 x 12 V DC 5 W 4-pin
IEC mains socket with power switch	2

### Input / Output Characteristics

Surface input impedance	10 kΩ
Non-clip maximum input level	+24 dBu
Analogue stepped gain	-2.5 dB to +45 dB plus -40 dB to +20 dB continuous digital trim
Phantom power (switchable per input)	+48 V

Talk mic impedance	5 k $\Omega$
Talk mic gain	+15 dB to +60 dB
Talk mic max level	+6 dB
Talkback impedance	20 k $\Omega$
Talkback gain	$\infty$ 0 to + 10 dB
Talkback max level	+21 dBu
Surface output impedance	50 $\Omega$
Surface output gain	0 dB
Surface output max level	+21 dBu
Dynamic range	106 dB, 22 Hz to 22 kHz, unweighted
Maximum voltage gain	100 dB inputs to subgroups and masters , 106 dB inputs to aux and matrix
Crosstalk at 1 kHz	-100 dB physically adjacent input channels
Crosstalk at 10 kHz	-90 dB physically adjacent input channels
Fader / pan cut off at 1 kHz	-100 dB
Fader / pan cut off at 10 kHz	-100 dB
Headphones output impedance	10 $\Omega$
Headphones maximum output level	+21 dBu

## Displays

Display screen	21" LCD high brightness 1920 x 1080 px, captive touchscreen, up to 10 simultaneous touches
LCD info displays	41 x full colour LCD info displays, 24 mm x 24 mm (size), 240 x 240 px
Input meters (quantity 30)	12 segment -35 dBu to +20 dBu
Output meters (quantity 7)	20 segment -36 dBu to +21 dBu
Channel comp meters (quantity 28)	5 segment -24 dBu to -1 dBu



**Products**

Community

Support

About

Downloads

Buy

Comp meter (quantity 1)

12 segment -23 dBu to -1 dBu

1000 1000 1000 1000

1000 1000 1000 1000

Gate meter (quantity 1)

12 segment -34 dBu to -1 dBu

## Controls

100 mm motorized faders

8 + 8 + 8 + 4

Touch-sensitive rotary controls

66

Custom controls

Fully assignable rotary controls

28 + 8

Fully assignable backlit buttons

28 + 8 + 12

Headphone controls

A and B, min to max

Talk

Talk gain min to max

# Quick Start Guide

EN

ES

FR

DE

PT

IT

NL

SE

PL

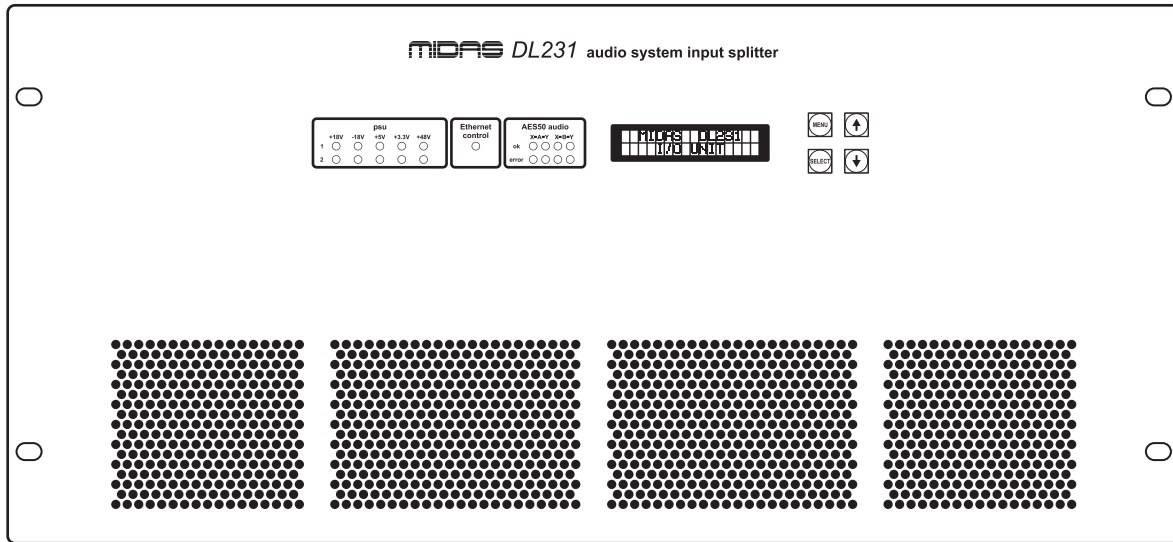

## DL231

24 Input, 24 Output Active Microphone Splitter with  
2 Independent Midas Microphone Preamplifiers per Input

# 1. Introduction

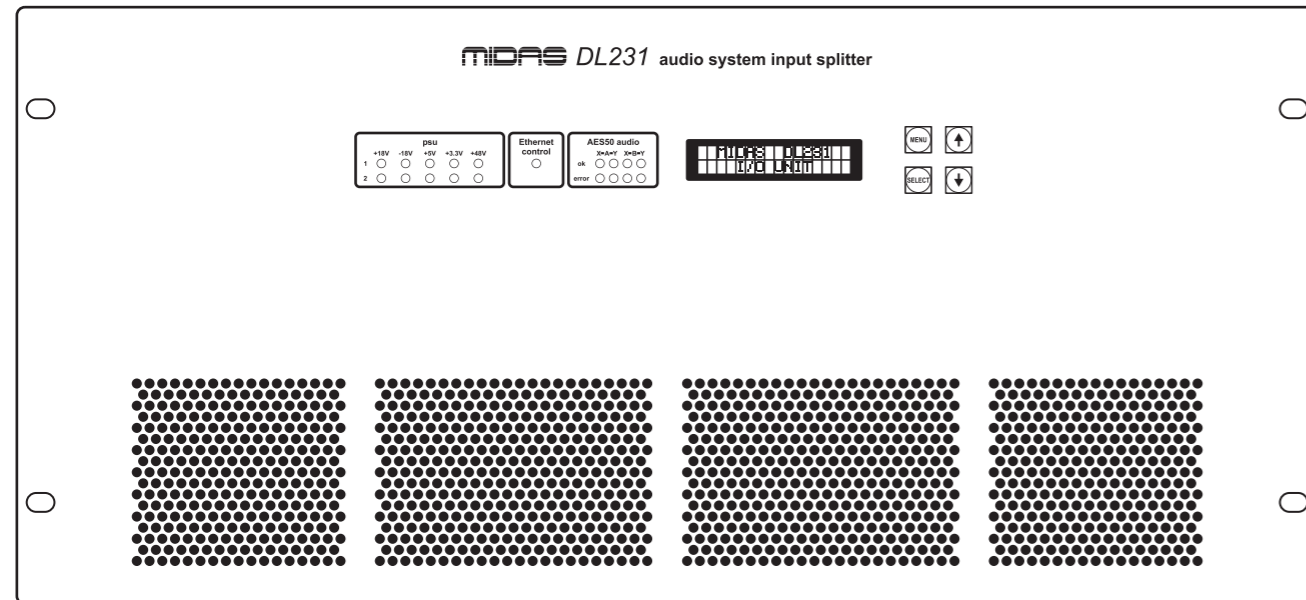

The DL231 - front panel

## Welcome!

Thank you for purchasing the DL231 Audio System I/O unit.

The Midas DL231 Audio System I/O unit is housed in a rugged 19" 2U rack-mount chassis with cosmetic trim, suitable for use and storage in a road flight case.

All user interface controls and feedback are located on the front panel. User interface controls are laid out for ease of operation with consideration for the amount of user feedback required. All switches are high quality momentary type with integral blue LED illumination and printed switch caps.

All primary connectors are on the rear of the unit. All inputs and outputs are on balanced XLR connectors. All analogue audio inputs and outputs are tolerant of 48 V connection and short circuit protected. The DL231 uses Neutrik XLR connections.

The DL231 I/O unit is a mixed technology product combining analogue and digital circuitry. These circuit types are combined on the input and output cards using multi-layer horizontal PCBs. Extreme care has been taken when planning and executing the PCB layout to maintain good grounding and analogue/digital separation.

The DL231 unit uses proven technology from the DL251 I/O unit from the current Midas range. The analogue input and output cards are identical, and the CPU card is a modified version of the one used in the DL251.

The user interface software is based on the same menu system currently used on existing Midas I/O units and has provision for all of the functions these units can perform.

Equipped with 48 channels of Midas premium mic-pre amplifiers with 2.5 dB ultra precise gain steps, the DL231 unit is an ideal partner for all Midas digital consoles (especially the XL8, PRO3/6/9 and PRO X consoles), significantly increasing mixable mic inputs.

## Integration Within The Midas Product Range

Styled to match existing Midas console livery, Midas high performance I/O has never been easier or more cost effective.

### Features

- 2 award-winning Midas microphone preamplifiers per channel with switchable +48 V phantom power
- 2 dual redundant AES50 network ports with independent phase-locked loop synchronisation
- 24 electronically balanced output channels can be sourced from microphone preamplifiers or AES50 ports
- Remote operation up to 100 m via CAT5/5e cable
- 24 bit audio operation with 96 kHz sample rate
- All settings programmable from front panel controls or console
- PSU status indicator LEDs and configuration LCD display on front panel
- Features Neutrik EtherCON\* AES50 network ports
- Rugged 5U rackmount chassis for durability in portable applications
- Dual redundant auto-ranging universal switch-mode power supplies
- 3-Year Warranty Program\*\*
- Designed and engineered in England

\*All third-party trademarks are the property of their respective owners. Their use neither constitutes a claim of the trademark nor affiliation of the trademark owners with Music Tribe. Product names are mentioned solely as a reference for compatibility, effects and/or components.  
\*\*Warranty details can be found at [musictribe.com](http://musictribe.com).

### About this manual

This is the operation manual for the DL231 I/O unit. This manual is intended to help get your unit installed and in operation as quickly as possible by giving you unpacking, installation, connection, setting up and operating instructions. To help familiarise you with the DL231, there is a description of the front and rear panels, along with easy-to-follow user instructions.

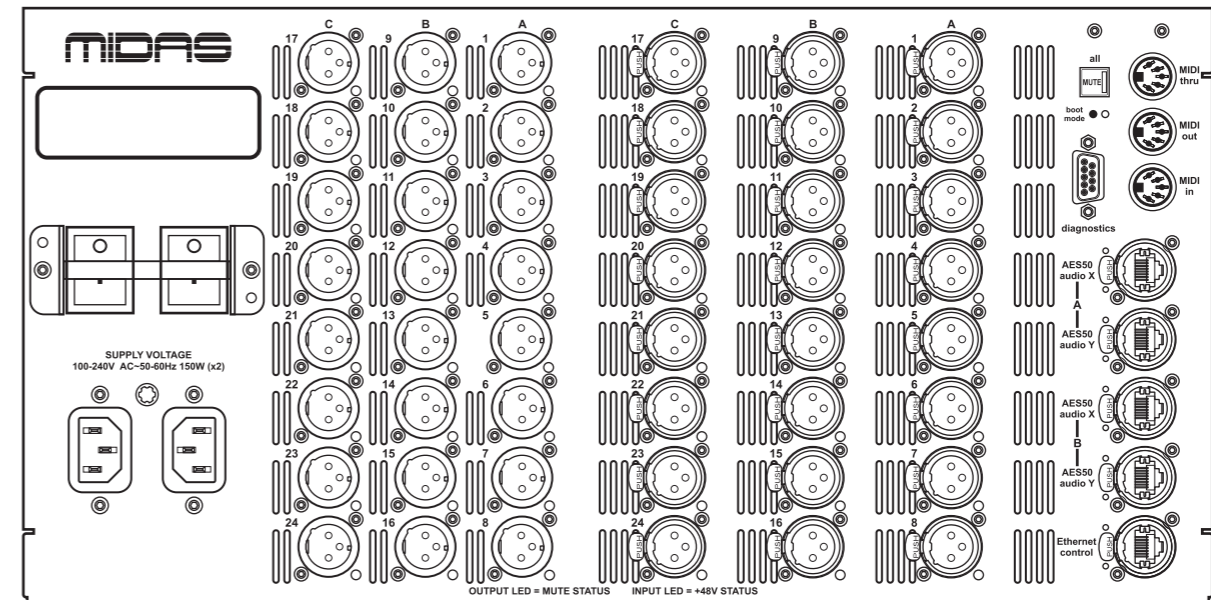

The DL231 - rear panel

# 2. Getting Started

This section shows you how to unpack, install, connect up, switch on and configure the DL231 I/O unit.



**This equipment is supplied by a mains voltage that can cause electric shock injury.**

**Before installing, setting up or operating this equipment, make sure that you have read and fully understand all of this section and the "Important safety instructions" at the front of this manual. Refer to additional safety information on the top cover of the unit.**

### Unpacking

Carefully unpack your DL231 I/O unit. Then, inspect the DL231 I/O unit carefully for any signs of damage that may have occurred during transit and notify the courier immediately if you discover any.

Check the contents of your DL231 I/O unit equipment package. If there are any parts missing, incorrect or faulty, please contact your local distributor or Midas at the address at the front of this manual.

Please retain the original packing in case you should need to return the equipment to the manufacturer or supplier, or transport or ship the unit later.

### Installation

Before installing and operating this equipment, make sure it is correctly connected to the protective earth conductor of the mains voltage supply socket outlet through each mains lead.

Ideally a cool area is preferred, away from power distribution equipment or other potential sources of interference.

Do not install the equipment in places of poor ventilation.

Do not install this equipment in a location subjected to excessive heat, dust or mechanical vibration. Allow for adequate ventilation around the equipment, making sure that its fans and vents are not obstructed. Whenever possible, keep the equipment out of direct sunlight.

Mount in rack only.

### Power

The internal power supplies are of the switch mode type that automatically senses the incoming mains voltage and will work where the nominal voltage is in the range 100 VAC to 240 VAC.

The correct leads for connection in the area to which the unit was shipped are supplied with the unit. The equipment should only be plugged into the mains outlets using the supplied leads.

Make sure the plug fitted on the supplied mains cable is securely fitted to the mains IEC connector on the unit. When fitting or removing a plug, always hold the plug itself and never use the cable, as this may damage it. Never insert or remove an electric plug with wet hands.

### Handling the equipment

When lifting or moving the equipment, always take its size and weight into consideration.

Completely isolate the equipment electrically and disconnect all cables from the equipment before moving it.

Do not insert your fingers or hands in any gaps or openings on the equipment, for example, vents.

### Electric fields

In accordance with Part 15 of the FCC Rules & Regulations, "... changes or modifications not expressly approved by the party responsible for compliance could void the user's authority to operate the equipment."

Should this product be used in an electromagnetic field that is amplitude modulated by an audio frequency signal (20 Hz to 20 kHz), the signal to noise ratio may be degraded. Degradation of up to 60 dB at a frequency corresponding to the modulation signal may be experienced under extreme conditions (3 V/m, 90% modulation).

### Connecting up

The DL231 I/O unit uses the following leads and connectors:

#### Primary Analogue Inputs:

Mic/Line Inputs - Balanced XLR connectors - 10K load

#### Primary Analogue Outputs:

Main Outputs - Balanced XLR connectors - 50R Source

#### AES50 Connections:

Neutrik EtherCON with status indication

#### Ethernet Control Connection:

Neutrik EtherCON with status indication

#### Diagnostics Connection:

9 W Female 'D' type connector

#### Power Connections:

IEC mains inlet - 100-240 V AC~50-60 Hz

For further information about the connectors used in conjunction with the DL231 I/O unit, see Section 5. Connectors.

## 3. Front Panel

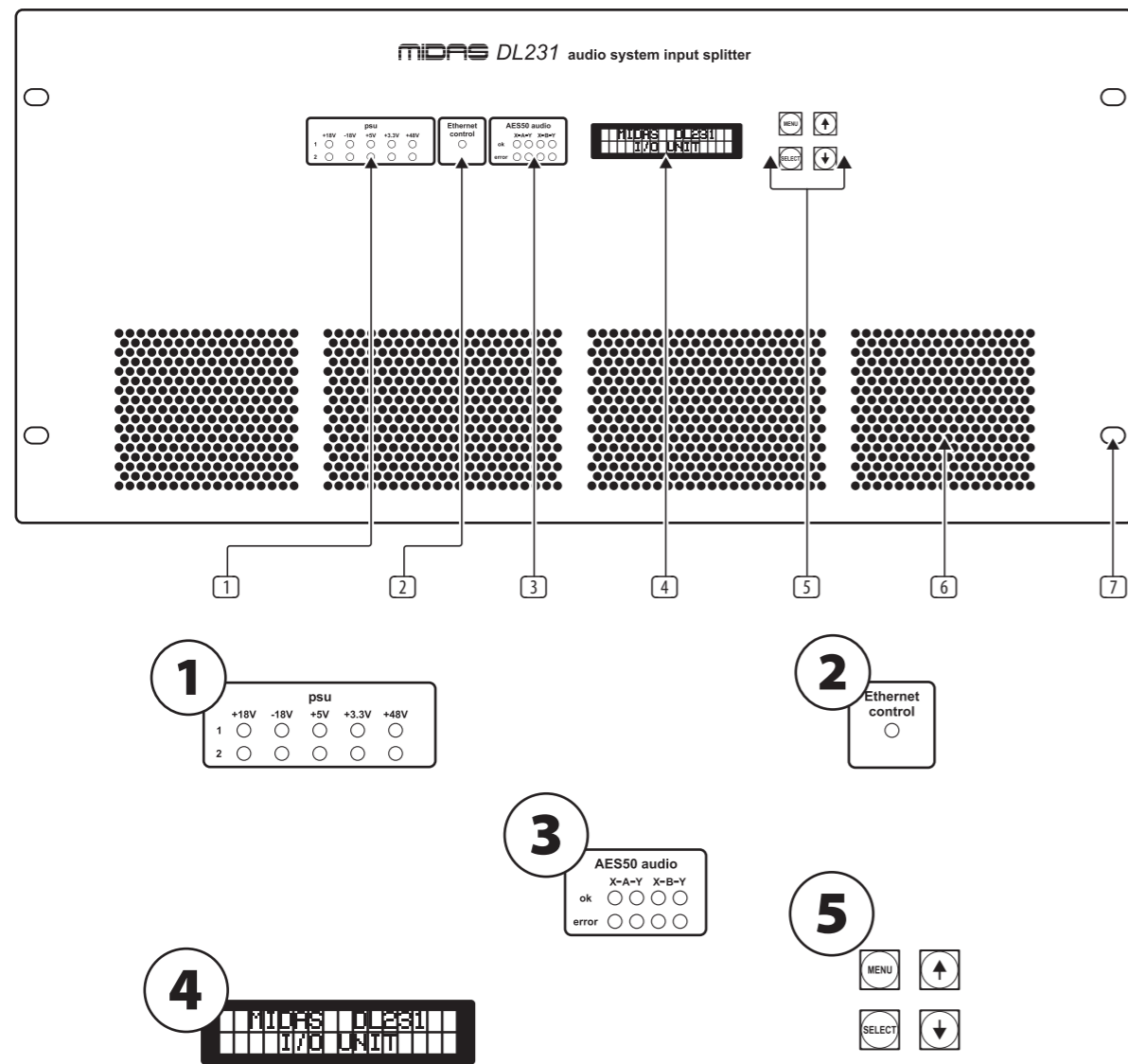

- 1 The **psu** panel monitors the two voltage supplies. There are five yellow LEDs per voltage supply, and each LED represents a voltage rail. An LED will illuminate when its respective voltage rail is active.
- 2 The **Ethernet control** panel has a single green LED, which has three states of illumination: flashing = active; on = connected; and off = not connected.
- 3 The **AES50 audio** panel shows the health status of the communications of the AES50 connections. If the green **ok** LED is illuminated, communication is good. However, if the red **error** LED is illuminated, there is a problem on that connection.
- 4 **LCD Display** - 2 x 16 character blue backlit liquid crystal display.
- 5 **Configuration Control** - 'Menu', 'Select', 'Up' and 'Down' buttons for configuring menu items.
- 6 There are four air intakes for fan cooling. **Do not obstruct.**
- 7 There are four cut-outs for rack mounting fixings.

## 4. Rear Panel

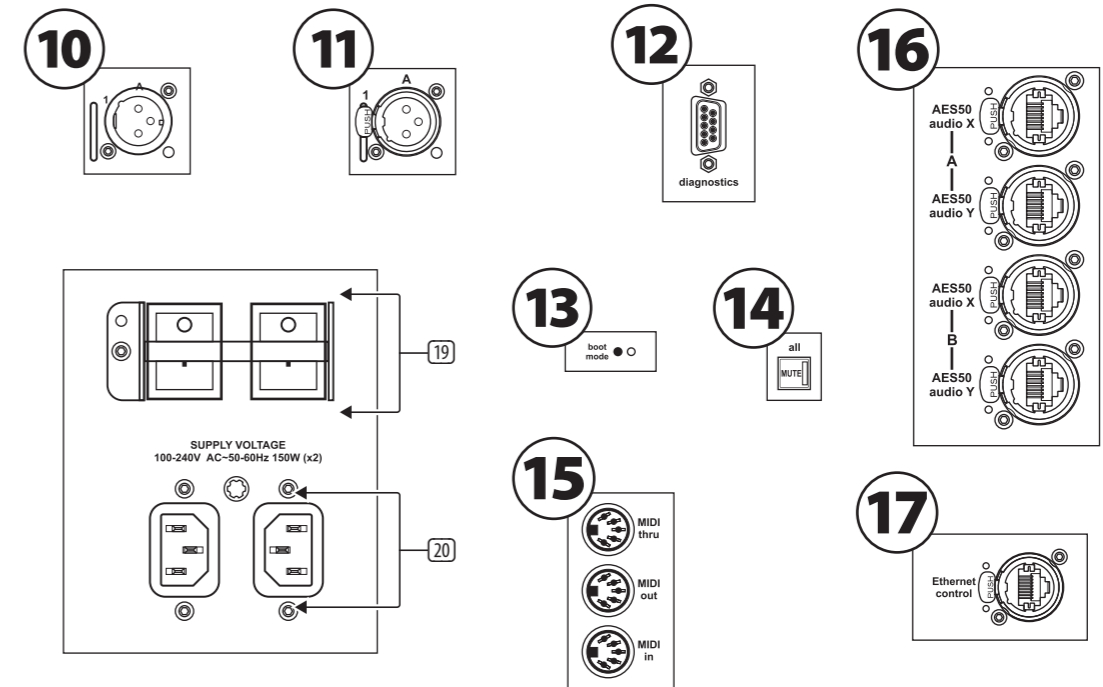
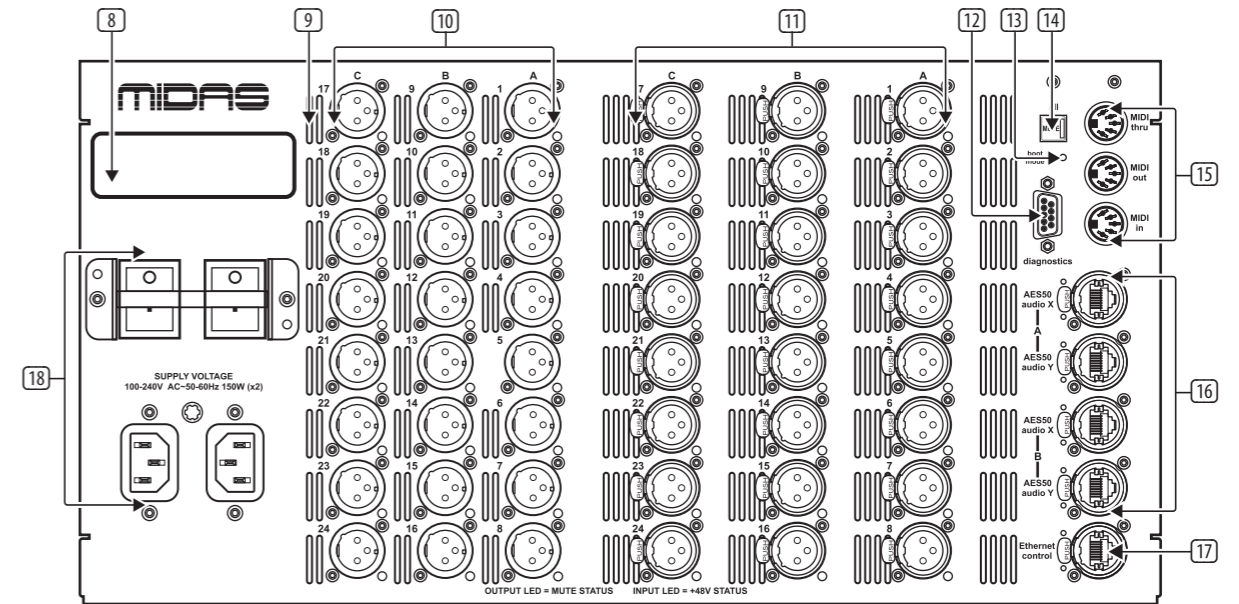

- 8 Unit serial number label.
- 9 Ventilation grills, which provide an air outtake for fan cooling of the inside of the unit.
- 10 Male XLR chassis connectors, which provide outputs for line equipment. Each socket has a red LED that illuminates when mute is on for that output.
- 11 Female XLR chassis connectors, which provide inputs for mic/line equipment. Each socket has a red LED that illuminates when +48 V phantom power is on for that input.
- 12 The **diagnostics** connector is a 9-way D-type connector for connecting a laptop/PC by service personnel for diagnostics purposes. **This is not an operator function and is only to be used by service personnel.**
- 13 The **boot mode** switch selects between normal operation and a service personnel-only configuration boot mode. It has an adjacent red LED, which illuminates to show when the unit is in service only configuration mode.
- 14 The **MUTE** button mutes all the outputs simultaneously when held down for longer than one second. It has an integral LED that illuminates when mute is active.
- 15 There are three MIDI (musical instrument digital interface) sockets — **MIDI in**, **MIDI out** and **MIDI thru** — for connection of a MIDI device, such as a synthesiser. The **MIDI in** socket receives MIDI data, and the **MIDI thru** socket gives out the same MIDI data that is received by the **MIDI in** socket. The **MIDI out** socket gives out MIDI data generated by the attached Midas Digital Console.

16 Four **AES50 audio** EtherCON sockets provide connection to the console and pass audio and control data in both directions. Each socket has a pair of red and green LEDs, which indicate the following:

- Green pulsating and red extinguished = valid audio and valid control data; active link.
- Green constantly illuminated and red extinguished = valid audio and valid control data; standby link.
- Green extinguished and red illuminated = no audio; link has failed.

17 The **Ethernet control** EtherCON socket on the rear panel allows Ethernet control via Cat 5e cable up to 100 m long. This socket has a green LED that indicates the following:

- Green LED solid = connected but not active
- Green LED flashing = active
- Green LED extinguished = fault or no connection

### Mains power



**Each mains inlet should be sourced from its own separate wall-mounted mains outlet socket. Otherwise, both mains sources must be suitably distributed so as to meet local safety regulations.**

The mains is supplied to the DL231 via dual redundant mains inlets.

- 18 Dual redundant power supplies.
- 19 Mains on/off isolator switch.
- 20 Mains IEC socket.

## 5. Connectors

To ensure the correct and reliable operation of the equipment, only high quality balanced, screened, twisted pair audio cable should be used. XLR connector shells should be of metal construction so that they provide a screen when connected to the console/snake and, where appropriate, they should have Pin 1 connected to the cable screen.

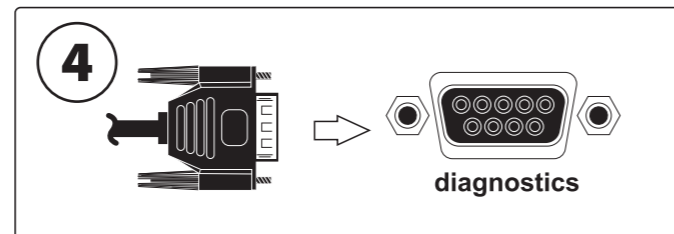
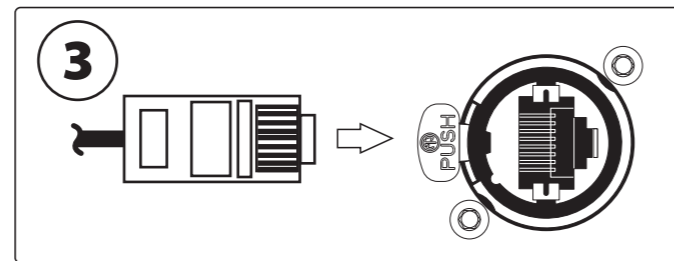
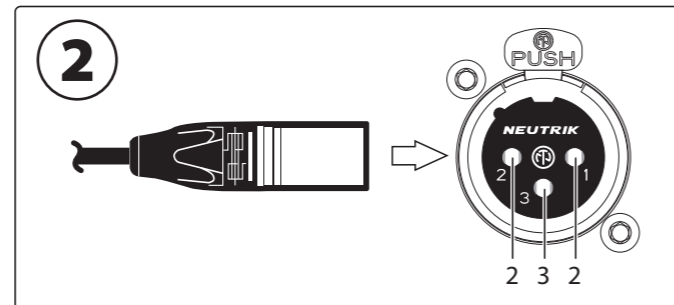
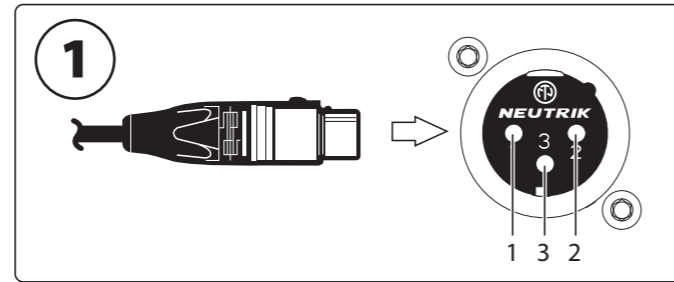

- 1 **Line output audio connector.** Female XLR plug and male XLR chassis connector with the following pinouts: 1 = ground; 2 = hot; and 3 = cold.
- 2 **Mic/line input audio connector.** Male XLR plug and female XLR chassis connector with the following pinouts: 1 = ground; 2 = hot; and 3 = cold.
- 3 **Ethernet socket.** RJ45 plug and EtherCON socket.
- 4 **Diagnostics.** 9-way, D-type plug and socket.

## 6. Operation

### Programming Mode

This chapter describes the programming mode of the DL231 I/O Unit.

### Menu navigation

The four programming buttons in the control panel have the following functions.

Navigation buttons	Usage
	Moves up or down a menu level, or exits programming mode, depending on the current menu level.
	Selects the current option.
	Scrolls through the current level of menus/options.
	Scrolls through the current level of menus/options in the opposite direction to the up arrow button.

The menu flowcharts on pages 17 through 21 give an overview of all the menus and their options, and shows you how to navigate your way around them. In the diagram the menus are shown on the left, and each subsequent lower level is to the right.

### To enter/exit programming mode

To enter programming mode, press the **MENU** button and hold down for approximately two seconds; the default display will change to the top-level "Select Menu:" display (see "Menus" on this page).

To exit programming mode from any menu display screen, press **MENU** repeatedly until you reach the default screen. The unit will exit programming mode automatically after about 20 seconds of inactivity if none of the programming buttons are pressed within that time.

### To select a menu

In programming mode, scroll to the menu you want by using the up/down arrow buttons, then press **SELECT**.

### Menus

The eight menus in programming mode are as follows:

1. **MicSplit ID** – for setting up the unit's network ID (see "MicSplit ID Menu" below).
2. **AES50 Sync** – for selecting the method for synchronizing the AES50 (see "AES50 Sync Menu" below).
3. **Output Source** – for setting up the output signal routing from the unit's analogue or AES50 digital inputs.
4. **48 V Control** – for controlling the source of 48 V phantom power.
5. **Sample Rate** – allows you to set the unit's sample rate (48k or 96k sample rates).
6. **AES50 Status** – lets you view/clear the AES50 values.
7. **S/W Version** – for viewing the unit's software version number.
8. **Reset All** – lets you reset all settings to default.

In programming mode the four programming buttons in the control panel are used to navigate and select options from a number of menus, which let you set up the unit and view information.

EN

ES

FR

DE

PT

IT

NL

SE

PL

## 7. Technical Specifications

This section contains the technical specifications for the DL231 I/O unit.

Due to our policy of continual improvement, Midas reserves the right to alter the function or specification at any time without notice.

### General Statistics

XLR Connections	
DL231	
1 x 5U rack I/O box houses:	24 x (XLR) mic/line inputs (48 mic/line amps) 24 x (XLR) line outputs
Resilience	
Dual redundant network cables and dual redundant PSUs	

### General Specifications

Sampling frequency	48 kHz/96 kHz
Dynamic range @ 1 kHz	22 Hz to 22 kHz (at unity gain): > 107 dB
Maximum gain	45 dB
Crosstalk @ 1 kHz	-90 dB physically adjacent input channels
Crosstalk @ 10k Hz	-90 dB physically adjacent input channels
Dimensions	5U x 410 mm deep
Net weight	15 kg
Shipping weight	18 kg
Power requirements	100 V to 240 V AC $\pm$ 10%, 50 to 60 Hz
Power consumption	<150 W
Operating temperature range	+5° C to +40° C
Storage temperature range	-20° C to +60° C

### Audio Performance Specifications

Frequency response				
Input	Output	Gain	20 Hz	20 kHz
DL231 I/O Box	DL231 I/O Box	0 dB	+0 dB to -1 dB	+0 dB to -1 dB
DL231 I/O Box	DL231 I/O Box	45 dB	+0 dB to -1 dB	+0 dB to -1 dB
Gain error at 1 kHz				
Input	Output	Gain	Max.	Min.
DL231 I/O Box	DL231 I/O Box	0 dB	+1 dB	-1 dB
DL231 I/O Box	DL231 I/O Box	45 dB	+1 dB	-1 dB
Input CMRR Typical				
Input	Output	Gain	100 Hz	1 kHz
DL231 I/O Box	DL231 I/O Box	0 dB	70 dB	70 dB
DL231 I/O Box	DL231 I/O Box	45 dB	90 dB	90 dB
Distortion at 0 dBu				
Input	Output	Gain	1 kHz	10 kHz
DL231 I/O Box	DL231 I/O Box	0 dB	0.01%	0.01%
DL231 I/O Box	DL231 I/O Box	45 dB	0.03%	0.03%
Distortion at +20 dBu				
Input	Output	Gain	1 kHz	10 kHz
DL231 I/O Box	DL231 I/O Box	0 dB	0.01%	0.01%
DL231 I/O Box	DL231 I/O Box	45 dB	0.03%	0.03%

#### Signal path noise 22 Hz to 22 kHz unweighted (inputs 150 $\Omega$ terminated)

Input	Output	Gain	Output noise	EIN
DL231 I/O Box	DL231 I/O Box	0 dB	-86 dBu	-86 dBu
DL231 I/O Box	DL231 I/O Box	45 dB	-81 dBu	-126 dBu

#### Dynamic range 22 Hz to 22 kHz unweighted

Input	Output	Gain	Maximum level	Dynamic range
DL231 I/O Box	DL231 I/O Box	0 dB	+21 dBu	107 dB
DL231 I/O Box	DL231 I/O Box	45 dB	+21 dBu	102 dB

### System Inputs and Outputs

#### I/O Box inputs

Connector	3-pin XLR balanced
A/D converter	24-bit, 96 kHz and 128 times oversampling

#### I/O Box outputs

Connector	3-pin XLR balanced
D/A converter	24-bit, 96 kHz and 128 times oversampling

#### MIDI

MIDI connector	In, out and through on 5-pin DIN (for use with Midas consoles only)
----------------	---

#### 48 kHz I/O digital system inputs and outputs

System connector A (X)	1 x AES50 (24 channels of bi-directional digital audio) on EtherCON XLR
Redundant connector A (Y)	1 x AES50 (24 channels of bi-directional digital audio) on EtherCON XLR providing redundant backup
System connector B (X)	1 x AES50 (24 channels of bi-directional digital audio) on EtherCON XLR
Redundant connector B (Y)	1 x AES50 (24 channels of bi-directional digital audio) on EtherCON XLR providing redundant backup

#### 96 kHz I/O digital system inputs and outputs

System connector A (X)	1 x AES50 (24 channels of bi-directional digital audio) on EtherCON XLR
Redundant connector A (Y)	1 x AES50 (24 channels of bi-directional digital audio) on EtherCON XLR providing redundant backup
System connector B (X)	1 x AES50 (24 channels of bi-directional digital audio) on EtherCON XLR
Redundant connector B (Y)	1 x AES50 (24 channels of bi-directional digital audio) on EtherCON XLR providing redundant backup

### Input and Output Characteristics

#### Analogue input characteristics

Input	Load Z	Gain	Max. level	Connector
DL231 I/O Box	10 k $\Omega$	-2.5 dB to +45 dB	+24 dBu	XLR

#### Analogue output characteristics

Output	Source Z	Gain	Max. level	Connector
DL231 I/O Box	50 $\Omega$	0 dB	+21 dBu	XLR

#### 48 kHz digital I/O characteristics

Type	AES50
Channels	24
Data length	24-bit
I/O	Bi-directional
Description notes	Conforms to AES50-2011
Connector	EtherCON XLR

#### 96 kHz digital I/O characteristics

Type	AES50
Channels	24
Data length	24-bit
I/O	Bi-directional
Description notes	Conforms to AES50-2011
Connector	EtherCON XLR



# Quick Start Guide

EN

ES

FR

DE

PT

IT

NL

SE

PL



## PRO SERIES DL155/DL154/DL153/DL152/DL151

Fixed Format I/O Unit

# PRO SERIES DL155/DL154/DL153/DL152/DL151 Controls

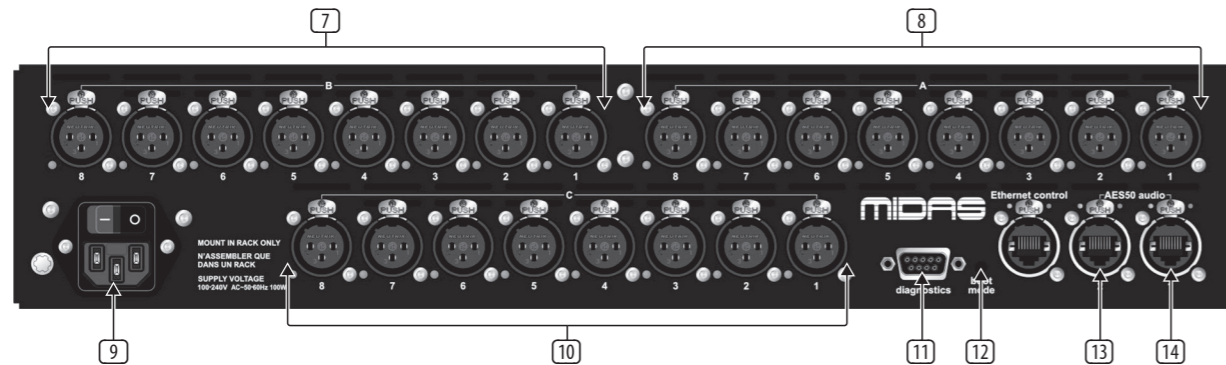

Applies to all DL15X models

## EN Controls

### FRONT PANEL

- 1 Ventilation Grill
- 2 PSU Status Indication - Power supply status LEDs for each power rail
- 3 Ethernet Control Status - Green status LED for the Ethernet control port
- 4 AES50 Status Indication - Green 'OK' and red 'ERROR' status LEDs for the AES50 ports
- 5 LCD - 2 x 16 character blue backlit liquid crystal display
- 6 Configuration Control - 'Menu', 'Select', 'Up' and 'Down' buttons for configuring menu items

### REAR PANEL

- 7 I/O Card 'A' - 8-channel I/O card position
- 8 I/O Card 'B' - 8-channel I/O card position
- 9 Mains Power Inlet - IEC inlet with integral mains switch
- 10 I/O Card 'C' - 8-channel I/O card position
- 11 Diagnostics port - 9W 'D' connector for diagnostics use
- 12 Activate Boot Mode
- 13 AES50 Ports - 2 x rugged Neutrik 'Ethercon' connectors with integral status LEDs
- 14 Ethernet Control Port - 1 x rugged Neutrik 'Ethercon' connector with integral status LEDs

## ES Controles

### PANEL FRONTAL

- 1 Rejilla de ventilación
- 2 Indicación de estado de la fuente de alimentación: LED de estado de la fuente de alimentación para cada riel de alimentación
- 3 Estado de control de Ethernet: LED de estado verde para el puerto de control de Ethernet
- 4 Indicación de estado AES50: LED de estado verde 'OK' y rojo 'ERROR' para los puertos AES50
- 5 LCD: pantalla de cristal líquido azul retroiluminada de 2 x 16 caracteres
- 6 Control de configuración: botones 'Menú', 'Seleccionar', 'Arriba' y 'Abajo' para configurar los elementos del menú

### PANEL TRASERO

- 7 Tarjeta de E/S 'A': posición de la tarjeta de E/S de 8 canales
- 8 Tarjeta de E/S 'B': posición de la tarjeta de E/S de 8 canales
- 9 Entrada de alimentación de red: entrada IEC con interruptor de red integrado
- 10 Tarjeta de E/S 'C': posición de la tarjeta de E/S de 8 canales
- 11 Puerto de diagnóstico: conector 'D' de 9 W para uso de diagnóstico
- 12 Activar el modo de arranque
- 13 Puertos AES50: 2 conectores robustos Neutrik 'Ethercon' con LED de estado integrados
- 14 Puerto de control Ethernet: 1 conector resistente Neutrik 'Ethercon' con LED de estado integrados

# Specifications

## External Connections

Primary Analogue Inputs	Mic / Line inputs - balanced XLR connectors - 10 k $\Omega$ load
Primary Analogue Outputs	Main Outputs - balanced XLR connectors - 50 $\Omega$ source
Primary Digital Inputs	XLR connectors - 110R
AES50 Connections	Neutrik Ethercon with status indication
Diagnostic Connection	9 W female 'D'-type connector
Power Connections	IEC mains inlet - 100-240 V AC~50-60 Hz $\pm$ 10%

## Audio Electronic Specifications

Maximum Input Level	Mic/Line (at unity gain)	+21 dBu
	Mic/Line (at -2.5 dB gain)	+24 dBu
CMR at 1 KHz (typical)	Mic (at unity gain)	> -70 dB
	Mic (at 40 dB gain)	> 90 dB
Noise	Mic EIN at 40 dB gain	-126 dBu
	Output noise at unity gain	-86 dBu
Frequency Response	20 Hz - 20 kHz	$\pm$ 0.5dB
Distortion at 1 kHz	Input to output (0 dB)	< 0.01%
Crosstalk at 1 kHz	Channel to channel	< -90 dB
Maximum Output Level	Line outputs (into 600R)	+21 dBu
Dynamic Range at 1 kHz	22 Hz - 22 kHz (at unity gain)	> 107 dB unweighted (20 Hz - 20 kHz)

## Power Requirements

Voltage	100 V AC to 240 V AC $\pm$ 10%
Frequency	50 Hz to 60 Hz
Consumption	<150 W

## Physical

Height	Approx 88.1 mm (2U)
Width	Approx 482.6 mm (19.0")
Depth	Approx 380 mm (15.0")
Net Weight	Approx 6.5 kg
Shipping Weight	Approx 8.5 kg
Operating temperature range	+5°C to 45°C
Storage temperature range	-20°C to +60°C

## Digital Inputs

Connector	AES3 (two channels of digital audio) on 3-pin XLR
Sample rates	Accepts any frequency between 32 k to 96 k
Bypass	Sample rate converter can be bypassed

## Digital Outputs

Connector	AES3 (two channels of digital audio) on 3-pin XLR
Sample rates	48 k, 96 k or auto tracking to inputs
Bypass	Sample rate converter can be bypassed
Word length	16-, 20- or 24-bit

# Quick Start Guide

EN

ES

FR

DE

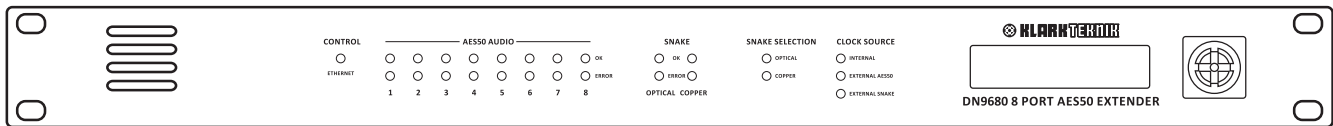

PT

IT

## DN9680

8 Port AES50 Extender and Multiplexer with up to 1000 Metre Range

NL

SE

PL

# DN9680 – Controls

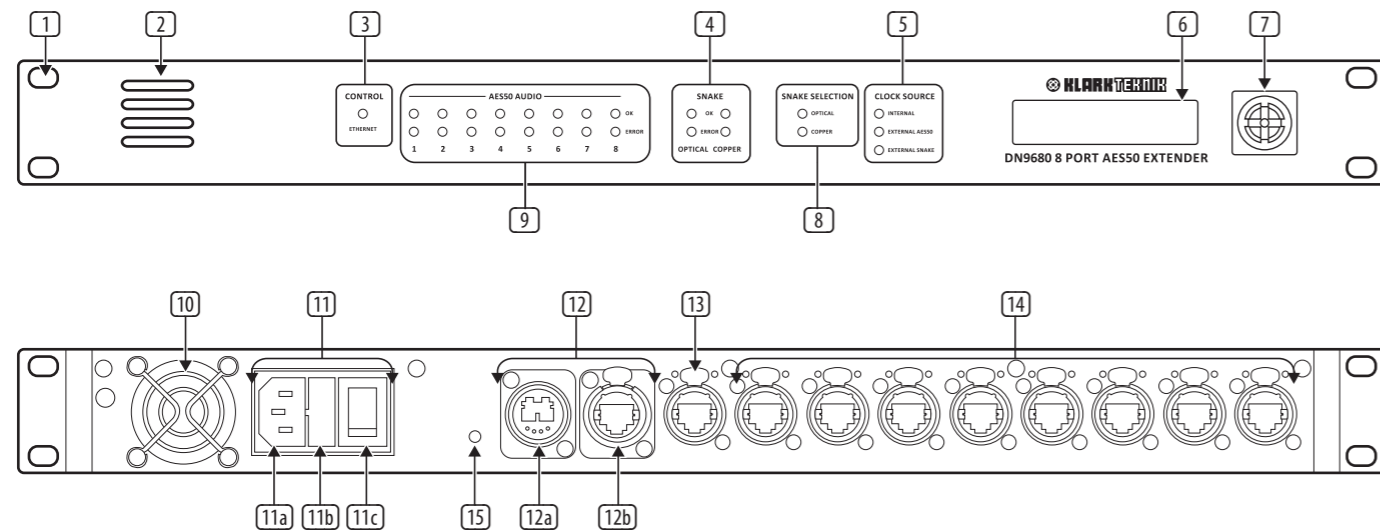

## EN Controls

### FRONT PANEL

- 1 Four holes for rack mounting.
- 2 Ventilation grill. **Do not obstruct.**
- 3 Ethernet control status LED. Shows the current activity on the **ETHERNET CONTROL** port, where: off = not connected; on = connected; and flashing = active communications.
- 4 Snake status LEDs. Show the status of the connected snake, where **OK** pulsates when the link is synchronised between router and end point, and **ERROR** illuminates to show no communications or a fault.
- 5 Shows the currently selected clock source, where: **INTERNAL** = the DN9680's internally generated clock is used; **EXTERNAL AES50** = the DN9680 automatically searches the AES50 ports for the first valid clock; and **EXTERNAL SNAKE** = the clock on the snake connection is used.
- 6 LCD display, which has 32 characters in a 16 x 2 configuration.
- 7 Backlit KLARK TEKNIK roundel, which illuminates light blue to show that the unit is powered up.

- 8 Shows the currently selected snake type.
- 9 AES50 audio status LEDs show the status of each AES50 port, where **OK** pulsates to show good communication and **ERROR** illuminates to show a communication error.

### REAR PANEL

- 10 Ventilation grill. **Do not obstruct.**
- 11 Mains power inlet. This is a switch mode power supply that has a mains IEC socket (11a), power on/off switch (11c) and a fuse drawer (11b) that houses an easily replaceable mains fuse.
- 12 Snake connectors for connecting the two DN9680s together via a single optical (12a) or Cat 5/5e (12b) snake.
- 13 Ethernet control port for connecting a PC/Mac for configuring the unit.
- 14 Eight AES50 connectors.
- 15 Reset button for resetting the unit to its factory default condition.

## ES Controles

### PANEL FRONTAL

- 1 Cuatro aperturas para montaje en bastidor.
- 2 Rejilla de ventilación. **¡No obstruir!**
- 3 LED de estado del control Ethernet. Indica la actividad presente en la toma **ETHERNET CONTROL**, donde: apagado = no conectado; encendido = conectado; e intermitente = comunicaciones activas.
- 4 LED de estado del snake. Indican el estado del cable snake que se tiene conectado: **OK** con iluminación pulsante para indicar que la conexión entre el enrutador y el punto final está sincronizada, y **ERROR** encendido para indicar que no hay comunicación o un fallo.
- 5 Indica el reloj que hay seleccionado actualmente, donde: **INTERNO** = uso del reloj interno del DN9680; **AES50 EXTERNO** = el DN9680 comprueba automáticamente las tomas AES50 para buscar el primer reloj válido; y **SNAKE EXTERNO** = uso del reloj en la conexión del snake.
- 6 Monitor LCD, de 32 caracteres en una configuración 16 x 2.
- 7 Icono KLARK TEKNIK retroiluminado; iluminación de color azul para indicar que la unidad está encendida.

- 8 Indica el tipo de snake actualmente seleccionado.
- 9 LED de estado de audio AES50; indican el estado de cada toma AES50: **OK** con iluminación pulsante (intensidad luminosa continuamente variable) para indicar buena comunicación, y **ERROR** encendido para indicar un error de comunicación.

### PANEL POSTERIOR

- 10 Rejilla de ventilación. **¡No obstruir!**
- 11 Toma de alimentación principal. Es una fuente de alimentación conmutada con una toma de alimentación tipo IEC (11a), un interruptor de alimentación (11c) y un portafusible (11b) con un fusible principal que puede cambiarse con facilidad.
- 12 Conectores de snake para conectar los dos DN9680 entre ellos con un snake óptico (12a) o Cat 5/5e (12b).
- 13 Toma de control Ethernet para conexión a PC / Mac para la configuración de la unidad.
- 14 Ocho conectores AES50.
- 15 Botón de rearme para restaurar la unidad a su estado predeterminado de fábrica.

# EN Specifications

## DN9680 General Specifications

Dimensions	1U high (44.5 mm (1.75")), 482.0 mm (19") wide, 410.0 mm (16.1") deep
Net weight	4.9 kg
Shipping weight	6.9 kg
Power consumption	50 W
Power requirement	110-240 V~, 50-60 Hz
Operating temperature range	+5°C to 45°C
Storage temperature range	-20°C to +60°C

## Inputs and Outputs

Audio	8 x AES50 etherCON ports with integral status LEDs
Snake (options)	1 x copper snake (cable can be up to 100 m long)
	1 x optical snake (cable can be up to 1000 m long)
Unit configuration port	1 x Ethernet control port for RJ45 connector
Mains power inlet	3-pin IEC connector



# NX 12-SMA

ACTIVE COAXIAL STAGE MONITOR



## Description

The NX 12-SMA is equipped with new high power 700 W digital amplifier and a newly designed 12" coaxial neodymium transducer that guarantees outstanding audio quality and definition as well as an extremely lightweight of the final system. The NX 12-SMA can be also used as a portable PA system, thanks to the rugged powder coated steel pole mount installed on the side. In order to control the response of the speaker in such different applications, RCF has incorporated two special Equalization Modes: - Floor, for stage monitoring; - Free Field, for the use of the speakers as a stand-alone PA system. Cabinet is made in Baltic Birch plywood, finished with an extremely resistant paint for an extensive use on the road. An ergonomic side handle, integrated with the input panel, is provided for an easier transport of the speaker.

## Features

- › 1400 Watt Peak, 700 Watt RMS digital bi-amplification
- › 129 dB max spl
- › 60° x 60° constant directivity horn
- › 12" High power neodymium woofer, 2.5" voice coil
- › 1.7" kapton dome, 1" exit, neodymium high frequency driver
- › DSP processing, floor - free field equalization, soft limiter and protection
- › Combo xlr/jack input, xlr signal output

## Part Number

13000235 NX 12-SMA  
13000236 NX 12-SMA

220-240 V  
115 V

Black  
Black

EAN 8024530008840  
EAN 8024530008857



# NX 12-SMA

## ACTIVE COAXIAL STAGE MONITOR

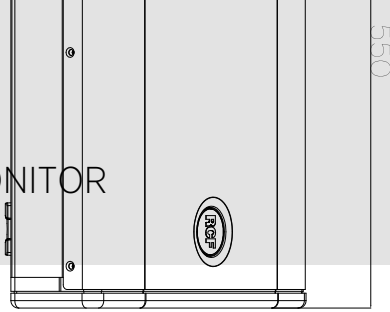

Line Art 2D

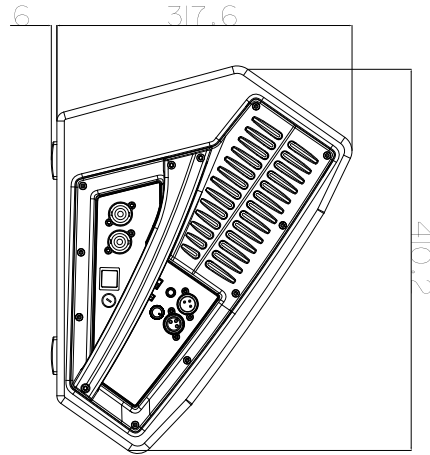

### TECHNICAL SPECIFICATIONS

<b>Acoustical specifications</b>	Frequency Response	50 Hz ÷ 20000 Hz
	Max SPL @ 1m	129 dB
	Horizontal coverage angle	60°
	Vertical coverage angle	60°
<b>Transducers</b>	Compression Driver	Coaxial 1.0" neo, 1.75" v.c
	Woofer	1 x 12" neo, 2.5" v.c
<b>Input/Output section</b>	Input signal	bal/unbal
	Input connectors	XLR, Jack
	Output connectors	XLR
	Input sensitivity	+4 dBu
<b>Processor section</b>	Protections	RMS, HF
	Limiter	Soft Limiter
	Controls	Freefield, floor
<b>Power section</b>	Total Power	1400 W Peak, 700 W RMS
	High frequencies	400 W Peak, 200 W RMS
	Low frequencies	1000 W Peak, 500 W RMS
	Cooling	Convection
	Connections	Powercon IN/OUT
<b>Standard compliance</b>	Safety agency	CE compliant
<b>Physical specifications</b>	Cabinet/Case Material	Baltic birch plywood
	Handles	1 on side
	Pole mount/Cap	Yes
	Grille	Steel
	Color	Black
<b>Size</b>	Height	324 mm / 12.76 inches
	Width	550 mm / 21.65 inches
	Depth	417 mm / 16.42 inches
	Weight	16.6 kg / 36.6 lbs





# NX 12-SMA

ACTIVE COAXIAL STAGE MONITOR

	<b>ACCESSORIES</b>		
<b>Cables</b>	AC XLR 3M3F	13360102	8024530006402
<b>Protections</b>	CVR NX12-SMA	13360168	8024530011680
<b>Rigging / Mounting</b>	AC PMX	13360232	8024530010058
	AC PRO-FS	13360109	8024530006471
	AC PRO-PM	13360110	8024530006488
	PM-KIT M20	13360067	8024530014599



# ~~ULX-D Dual and Quad~~

## Wireless Microphone System

User guide for Shure ULXD Dual and Quad wireless system. Includes setup instructions, specifications, and troubleshooting  
Version: 7.2 (2024-D)

# ULX-D ~~Dual~~ and Quad Wireless Microphone System

## Quickstart Instructions

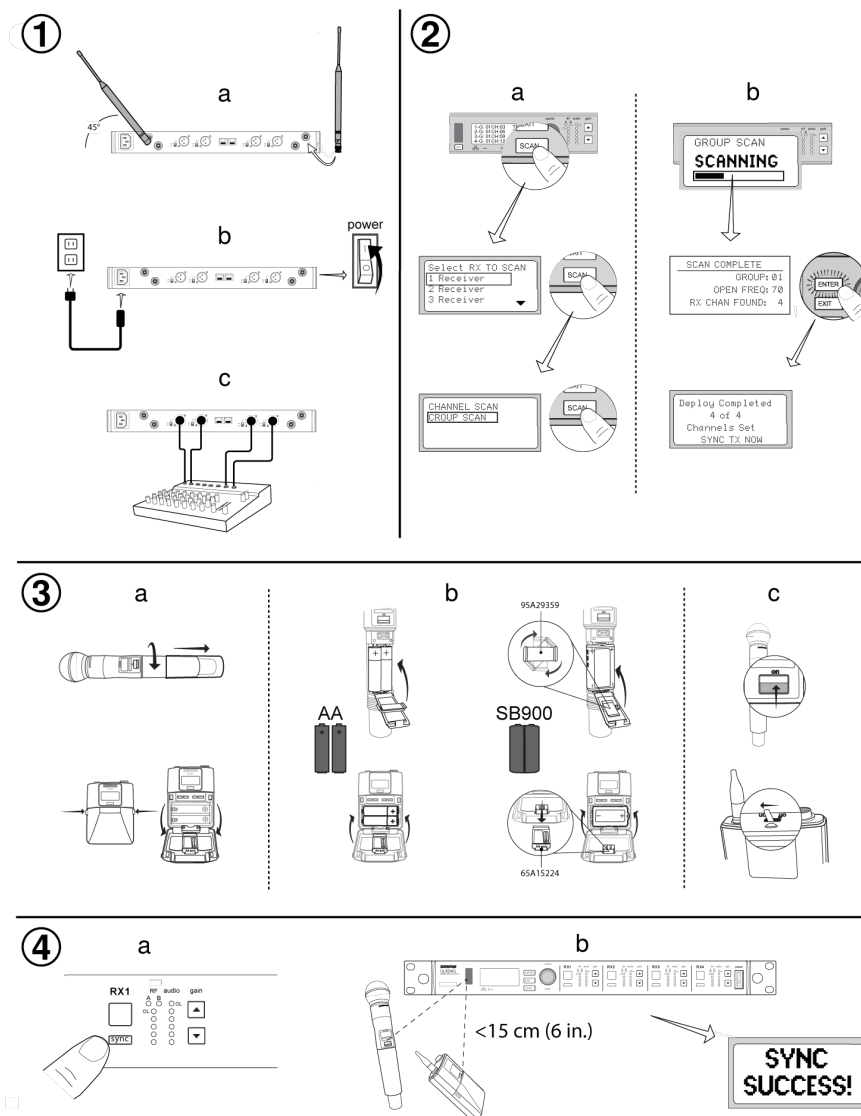

## General Description

Shure ULX-D™ Digital Wireless offers uncompromising 24-bit audio quality and RF performance, with intelligent, encryption-enabled hardware, flexible receiver options, and advanced rechargeability options for professional sound reinforcement.

A breakthrough in wireless audio quality, Shure digital processing enables ULX-D to deliver the purest reproduction of source material ever available in a wireless system, with a wide selection of trusted Shure microphones to choose from. Extended 20 Hz – 20 kHz frequency range and flat response captures every detail with clarity, presence, and incredibly accurate low end and transient response. With greater than 120 dB, ULX-D delivers wide dynamic range for excellent signal-to-noise performance. Optimized for any input source, ULX-D eliminates the need for transmitter gain adjustments.

ULX-D sets a new and unprecedented standard for spectral efficiency and signal stability. The intermodulation performance of ULX-D is an incredible advancement in wireless performance, enabling a dramatic increase in the number of simultaneous active transmitters on one TV channel. Rock-solid RF signal with zero audio artifacts extends over the entire range. For applications where secure wireless transmission is required, ULX-D offers Advanced Encryption Standard (AES) 256-bit encrypted signal for unbreakable privacy.

For scalability and modular flexibility, ULX-D receivers come in single, dual, and even quad channel versions. The dual and quad channel receivers offer conveniences such as RF cascade, internal power supply, bodypack frequency diversity, audio output channel summing, and Dante™ digital networking for multi-channel audio over Ethernet. All receivers offer High-Density mode for applications where high channel counts are needed, greatly increasing the amount of simultaneous channels possible over one frequency band.

Advanced Lithium-ion rechargeability provides extended transmitter battery life over alkaline batteries, battery life metering in hours and minutes accurate to within 15 minutes, and detailed tracking of battery health status.

Generations ahead of any other available system in its class, ULX-D brings a new level of performance to professional sound reinforcement.

## Dual and Quad Receiver Models

The ULXD4 receiver is available in dual channel and quad channel models. Both models share the same feature set and functionality, but differ in the number of channels available and the number of audio outputs.

The descriptions and procedures in this guide are applicable to either the dual or the quad receiver.

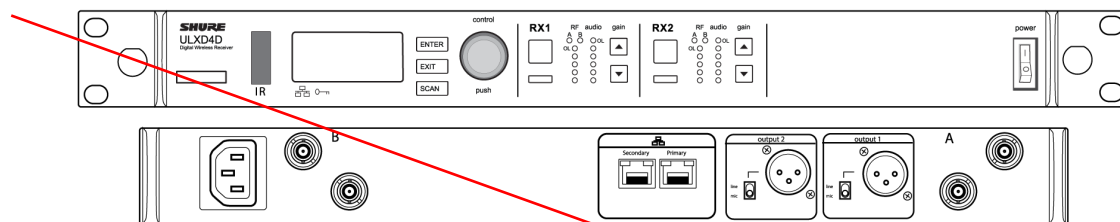

**ULXD4D Dual Receiver**

*Supports 2 channels of wireless audio.*

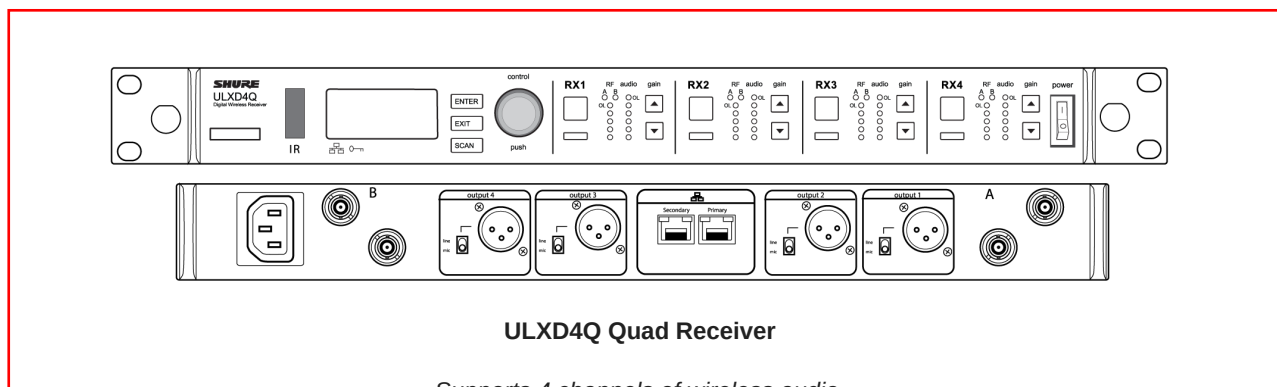

**ULXD4Q Quad Receiver**

*Supports 4 channels of wireless audio.*

Accessory	Part number
Y-Cable for bodypack transmitters	AXT652
Antenna Distribution System	UA845SWB
Passive Antenna/Splitter Combiner Kit (recommended for 2 receivers)	UA221
In-Line Antenna Amplifier, 470-698MHz	UA830USTV
UHF Antenna Power Distribution Amplifier (recommended for 3 or more receivers)	UA844SWB
In-Line Power Supply	UABIAST
Front Mount Antenna Kit (Includes 2 Cables And 2 Bulk-head)	UA600
1/2 Wave Antenna Remote Mount Kit	UA505
Active Directional Antenna 470-900MHZ	UA874WB
Passive Directional Antenna 470-952 MHz. Includes 10 foot BNC to BNC cable.	PA805SWB
2 ft. BNC-BNC Coaxial Cable	UA802
6 foot (1.8m) BNC to BNC Coaxial Cable for Remote Antenna Mounting for ULX Wireless System	UA806
25 ft. BNC-BNC Coaxial Cable	UA825
50 ft. BNC-BNC Coaxial Cable	UA850
100 ft. BNC-BNC Coaxial Cable	UA8100

## Specifications

### ULX-D System Specifications

#### RF Carrier Frequency Range

470–932 MHz, varies by region (See Frequency Range and Output Power table)

#### Working Range

100 m ( 330 ft)

Note: Actual range depends on RF signal absorption, reflection and interference. Note: Actual range depends on RF signal absorption, reflection and interference.

#### RF Tuning Step Size

25 kHz, varies by region

**Image Rejection**

&gt;70 dB, typical

**RF Sensitivity**-98 dBm at  $10^{-5}$  BER**Latency**

&lt;2.9 ms

**Audio Dynamic Range***A-weighted, typical, System Gain @ +10*

<b>XLR Analog Output</b>	>120 dB
<b>Dante Digital Output</b>	130 dB

**Total Harmonic Distortion***-12 dBFS input, System Gain @ +10*

&lt;0.1%

**System Audio Polarity**

Positive pressure on microphone diaphragm produces positive voltage on pin 2 (with respect to pin 3 of XLR output) and the tip of the 6.35 mm (1/4-inch) output.

**Operating Temperature Range**

-18°C (0°F) to 50°C (122°F)

Note: Battery characteristics may limit this range.

**Storage Temperature Range**

-29°C (-20°F) to 74°C (165°F)

Note: Battery characteristics may limit this range.

~~ULXD4D~~ & **ULXD4Q****ULXD4D****Weight**

3.36 kg (7.4 lbs), without antennas

**Power Requirement**

100 to 240 V AC, 50-60 Hz, 0.26 A max.

**ULXD4Q****Weight**

3.45 kg (7.6 lbs), without antennas

**Power Requirement**

100 to 240 V AC, 50-60 Hz, 0.32 A max.

## ULXD4D & ULXD4Q

### Dimensions

44 x 482 x 274 mmH x W x D

### Housing

steel; Extruded Aluminum

## Audio Output

### Gain Adjustment Range

-18 to +42 dB in 1 dB steps (plus Mute setting)

### Configuration

<b>XLR</b>	balanced (1=ground, 2=audio +, 3=audio -)
------------	---

### Impedance

100  $\Omega$

### Full Scale Output

<b>LINE setting</b>	+18 dBV
<b>MIC setting</b>	-12 dBV

### Mic/Line Switch

30 dB pad

### Phantom Power Protection

Yes

## Cascade Output

### Connector Type

BNC

Note: For connection of one additional receiver in the same band

### Configuration

Unbalanced, passive

### Impedance

50  $\Omega$

### Insertion Loss

0 dB

## Networking

### Network Interface

Dual Port Ethernet 10/100 Mbps, 1Gbps, Dante Digital Audio

### Network Addressing Capability

DHCP or Manual IP address

### Maximum Cable Length

100 m (328 ft)

## RF Input

### Spurious Rejection

>80 dB, typical

### Connector Type

BNC

### Impedance

50  $\Omega$

### Bias Voltage

12 to 13 V DC, 150 mA maximum, per antenna

switchable on-off

## ULXD1

### Mic Offset Range

0 to 21 dB (in 3 dB steps)

### Audio Frequency Response

20 – 20 kHz ( $\pm 1$  dB)

### Battery Type

Shure SB900B Rechargeable Li-Ion or LR6 AA batteries 1.5 V

### Battery Runtime

@ 10 mW

<b>Shure SB900B</b>	>8 hours
<b>alkaline</b>	9 hours

See Battery Runtime Chart

### Dimensions

86 mm x 66 mm x 23 mm (3.4 in. x 2.6 in. x 0.9 in.) H x W x D

### Weight

142 g (5.0 oz.), without batteries

### Housing

Cast aluminum



## Audio Input

### Connector

4-Pin male mini connector (TA4M), See drawing for details

### Configuration

Unbalanced

### Impedance

1 M $\Omega$ , See drawing for details

### Maximum Input Level

1 kHz at 1% THD

<b>Pad Off</b>	8.5 dBV ( 7.5 Vpp)
<b>Pad On</b>	20.5 dBV ( 30 Vpp)

### Preamplifier Equivalent Input Noise (EIN)

System Gain Setting  $\geq$  +20-120 dBV, A-weighted, typical

## RF Output

### Connector

SMA

### Antenna Type

1/4 wave

### Impedance

50  $\Omega$

### Occupied Bandwidth

<200 kHz

### Modulation Type

Shure proprietary digital

### Power

1 mW, 10 mW, 20 mW

See Frequency Range and Output Power table, varies by region

## ULXD2

### Mic Offset Range

0 to 21 dB (in 3 dB steps)

### Audio Frequency Response

Note: Dependent on microphone type

### Battery Type

Shure SB900B Rechargeable Li-Ion or LR6 AA batteries 1.5 V

### Battery Runtime

@ 10 mW

<b>Shure SB900B</b>	>8 hours
<b>alkaline</b>	9 hours

See Battery Runtime Chart

### Dimensions

<b>VHF V50 and V51</b>	278 mm x 51 mm (10.9 in. x 2.0 in.) L x Dia.
<b>Other frequency bands</b>	256 mm x 51 mm (10.1 in. x 2.0 in.) L x Dia.

### Weight

<b>VHF V50 and V51</b>	348 g (12.3 oz.), without batteries
<b>Other frequency bands</b>	340 g (12.0 oz.), without batteries

### Housing

Machined aluminum

## Audio Input

### Configuration

Unbalanced

### Maximum Input Level

1 kHz at 1% THD 145 dB SPL (SM58), typical

Note: Dependent on microphone type

## RF Output

### Antenna Type

Integrated Single Band Helical

### Occupied Bandwidth

<200 kHz

### Modulation Type

Shure proprietary digital

### Power

1 mW, 10 mW, 20 mW

See Frequency Range and Output Power table, varies by region

## Tables and Diagrams

### TA4M Connector

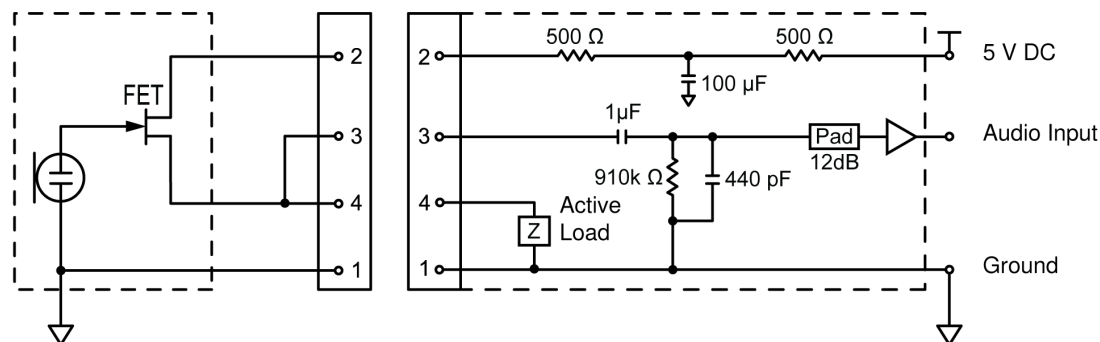



## LEMO Connector

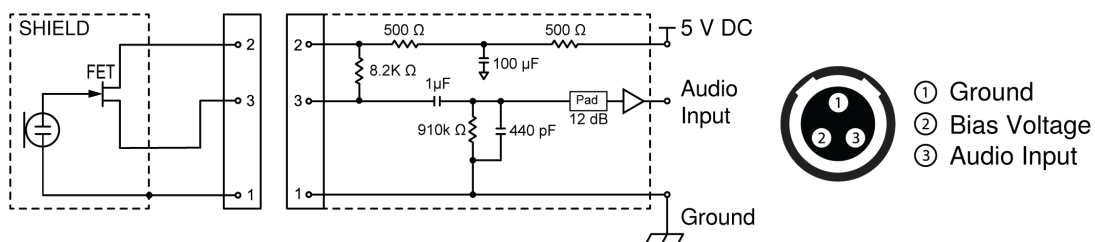

## XLR to 1/4 Output

Use the following wiring diagram to convert the XLR output to a 1/4 output.

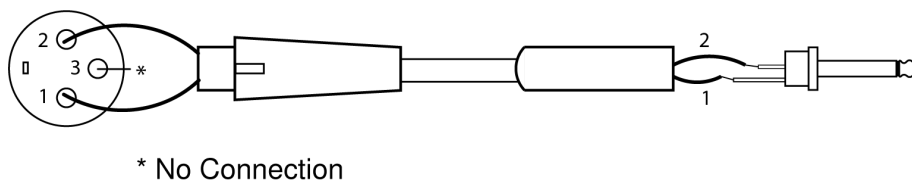

## Batteries

### ULXD Battery Life

MHz	hours			
	SB900B		alkaline	
	1/10 mW	20 mW	1/10 mW	20 mW
470 to 810	>8:30	>5:40	>8	>5:30
902 to 928	>7:30	>4:40	>7	>4
174 to 216	>8:30	>6:35	8	>5
1240 to 1800	>8	>6:05	>6	>4:30

**Note:** The SB900B Shure rechargeable battery uses SBC200, SBC800 and SBC220 chargers.

The values in this table are typical of fresh, high quality batteries. Battery runtime varies depending on the manufacturer and age of the battery.

## Frequency Range and Transmitter Output Power

Band	Frequency Range ( MHz )	Power ( mW RMS )* (Lo/Nm/Hi)
G50	470 to 534	1/10/20
G51	470 to 534	1/10/20
G52	479 to 534	1/10
G53	470 to 510	1/10/20
G62	510 to 530	1/10/20
H50	534 to 598	1/10/20
H51	534 to 598	1/10/20
H52	534 to 565	1/10
J50	572 to 636	1/10/20
J50A $\Delta$	572 to 608	1/10/20
J51	572 to 636	1/10/20
K51	606 to 670	1/10
L50	632 to 696	1/10/20
L51	632 to 696	1/10/20
L53	632 to 714	1/10/20
M19	694 to 703	1/10/20
P51	710 to 782	1/10/20
R51	800 to 810	1/10/20
JB (Tx only)	806 to 810	1/10
AB (Rx and Tx)	770 to 810	A Band (770-805): 1/10/20
		B Band (806-809): 1/10
Q12	748 to 758	1/10/20
Q51	794 to 806	10
V50	174 to 216	1/10/20
V51	174 to 216	1/10/20
V52	174 to 210	10
X50	925 to 932	1/10

Band	Frequency Range ( MHz )	Power ( mW RMS )* (Lo/Nm/Hi)
X51	925 to 937.5	10
X52	902 to 928	0.25/10/20
X53	902 to 907.500, 915 to 928	0.25/10/20
X54	915 to 928	0.25/10/20
Z16	1240 to 1260	1/10/20
Z17	1492 to 1525	1/10/20
Z18	1785 to 1805	1/10/20
Z19	1785 to 1800	1/10/20
Z20	1790 to 1805	1/10/20

△ Output power limited to 10 mW above 608 MHz.

**Note:** Frequency bands might not be available for sale or authorized for use in all countries or regions.

\* Power delivered to the antenna port

For the band Z17 (1492-1525 MHz), it must be used indoors only.

For the Band Z19 (1785-1800MHz) used in Australia, per Radio Communications Low Interference Potential Devices Class License 2015; item 30 note C: the system must be operated within the range of 1790-1800MHz when used outdoors.

#### 低功率射頻器材技術規範

取得審驗證明之低功率射頻器材，非經核准，公司、商號或使用者均不得擅自變更頻率、加大功率或變更原設計之特性及功能。低功率射頻器材之使用不得影響飛航安全及干擾合法通信；經發現有干擾現象時，應立即停用，並改善至無干擾時方得繼續使用。前述合法通信，指依電信管理法規定作業之無線電通信。低功率射頻器材須忍受合法通信或工業、科學及醫療用電波輻射性電機設備之干擾。

เครื่องโทรคมนาคมและอุปกรณ์นี้มีความสอดคล้องตามมาตรฐานหรือข้อกำหนดทางเทคนิคของ กสทช.

## IMPORTANT SAFETY INSTRUCTIONS

1. READ these instructions.
2. KEEP these instructions.
3. HEED all warnings.
4. FOLLOW all instructions.
5. DO NOT use this apparatus near water.
6. CLEAN ONLY with dry cloth.
7. DO NOT block any ventilation openings. Allow sufficient distances for adequate ventilation and install in accordance with the manufacturer's instructions.



## ULXD2/SM58

### Digital Handheld Transmitter with SM58 Capsule

SKU: ULXD2/SM58-G50

★★★★★ 0.0 | No Reviews | [Write the First Review](#)

Frequency Band:

- G50**
- H50
- J50A
- V50
- X52

[Find my frequency](#)

#### Overview



#### Details



- AES 256-bit encryption for applications for which secure transmission is needed
- Proprietary Shure Gain Ranging optimizes the system's dynamic range for any input source, eliminating the need for transmitter gain adjustments
- Optional Shure SB900B lithium-ion rechargeable battery pack provides over 12 hours of battery life, precision metering in hours and minutes, and zero memory effect
- External charging contacts for docked charging (with the SBC200 Dual Docking Charger)
- Transmitter Mute Mode repurposes the On/Off switch into a mute switch, enabling audio muting while preserving RF channel presence
- Backlit LCD with easy to navigate menu and controls
- Rugged metal construction
- Frequency and power lockout

The ULXD2/SM58 Handheld Wireless Microphone Transmitter works with ULX-D Wireless Systems.

Note: When purchasing separate wireless components, please match their frequency bands to ensure proper system operation.



# UA844plus SWB

## Antenna Distribution System

The Shure UA844SWB antenna distribution system user guide.  
Version: 4.1 (2023-C)

---

# Table of Contents

<b>UA844plus SWB Antenna Distribution System</b>	<b>3</b>	<b>Accessories</b>	<b>6</b>
<b>General Description</b>	<b>3</b>	System Components	6
Model Variations	3	Optional Accessories	6
<b>Front and Rear Panels</b>	<b>3</b>	<b>Specifications</b>	<b>6</b>
<b>Connecting Multiple UA844 Systems</b>	<b>5</b>	<b>Certifications</b>	<b>8</b>
		<b>Important Product Information</b>	<b>8</b>
		LICENSING INFORMATION	8



# UA844plus SWB Antenna Distribution System

## General Description

The Shure Model UA844+ is an antenna distribution system that allows for the expansion of wireless microphone systems by splitting one pair of antennas to multiple receivers. It also amplifies RF signals to compensate for insertion loss that results from splitting signal power to multiple outputs. A single UA844+ system can support up to five wireless receivers. A maximum of five UA844+ systems may be used in a two-tiered configuration.

## Model Variations

### UA844+ Model Variations

<b>UA844+V</b>	174-216 MHz
<b>UA844+SWB</b>	470-960 MHz
<b>UA844+Z16</b>	1240-1260 MHz
<b>UA844+Z17</b>	1492-1525 MHz
<b>UA844+Z18</b>	1785-1805 MHz

**Note:** Some units include a power switch on the front panel to meet regional regulations.

## Front and Rear Panels

- ① Antenna A Connector
- ② Power Indicator
- ③ Power Switch (country dependent)
- ④ Antenna B Connector
- ⑤ 15 V dc (2.54 A) power input
- ⑥ Power Output for receivers. Do not connect to additional distribution systems
- ⑦ RF Input Antenna B
- ⑧ Cascade (2)
- ⑨ RF Output B
- ⑩ RF Output A
- ⑪ RF Input Antenna A



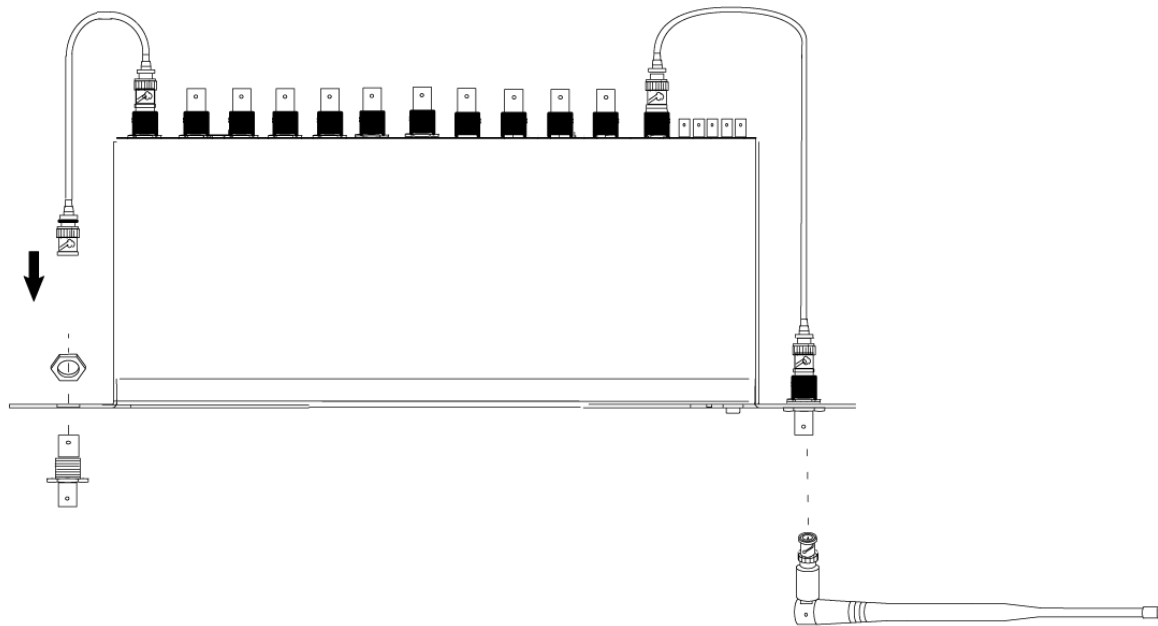

## Installation and Cable Connections



# Connecting Multiple UA844 Systems

1. Connect the Cascade outputs of the primary UA844 to the A and B antenna inputs of the secondary UA844.
2. For additional systems, connect remaining A and B RF outputs on the primary UA844 to the A and B antenna inputs of the secondary UA844s.
3. Connect any available A and B RF outputs on the primary and secondary UA844 units to the antenna inputs of the wireless receivers.

## Accessories

### System Components

- Front-mounting antenna hardware
- Rack-mounting hardware
- External power supply
- (2) 6 ft. BNC cables
- (4) Non-locking DC power cords (QLXD4, SLX4, BLX4R)
- (10) 22 in. BNC cables\*
- (4) Locking DC power cords\*\* (ULXD4)

\*Model UA844+/LC substitutes (2) 22 in. BNC cables.

\*\*Not included with Model UA844+/LC

### Optional Accessories

<b>1/2 Wave Omnidirectional Receiver Antenna for improved wireless signal reception</b>	UA8
<b>In-Line RF Amplifier compensates for signal loss over extended cable runs</b>	UA834
<b>UA874 Active Directional Antenna for improved wireless signal reception with greater rejection of unwanted signals</b>	UA874
<b>1/2 Wave Antenna Remote Mount Kit</b>	UA505
<b>Antenna Rack Panel with Cables and BNC Adapters</b>	UA440

**Note:** Be sure to select antennas and accessories that are compatible with the operating frequency range of your wireless system. Contact Shure or your local retailer for help with selecting the right wireless accessories.

### Selecting Antenna Cables

Use 50 ohm low-loss coaxial cable, such as RG-8U. Shure offers pre-terminated antenna cables ranging from 6 to 100 feet.

**NOTE:** When ordering cables from Shure, select the low-loss "Z" models (available for longer cables) when using frequency bands above 1000 MHz.

## Specifications

### Power Requirements

14 to 18 V DC

## DC Output

14 to 18 V DC (x4)

## Output Current

*Combined total from all DC outputs*

2.5 A, maximum

## Operating Temperature Range

-18°C (0°F) to 63°C (145°F)

## Dimensions

45 x 483 x 172 mm (H x W x D)

## Net Weight

1.62 kg (3.6 lbs)

## RF Input

### Connector Type

BNC

### RF Frequency Range

*model dependent*

174 to 1805 MHz

### Bias Voltage

15 V DC (150 mA, maximum) (x2)

### Impedance

50  $\Omega$

## RF Output

### RF Frequency Range

*model dependent*

174 to 1805 MHz

### Output Intercept Point

21 dBm, typical

### Connector Type

BNC

### Impedance

50  $\Omega$

### Output Connector Isolation

30 dB, typical

## Gain

*Input to any output port (Unused ports terminated in 50  $\Omega$ )*

-1 to +1 dB

---

## Certifications

The CE Declaration of Conformity can be obtained from Shure Incorporated or any of its European representatives. For contact information please visit [www.shure.com](http://www.shure.com)

The CE Declaration of Conformity can be obtained from: [www.shure.com/europe/compliance](http://www.shure.com/europe/compliance)

Authorized European representative:

Shure Europe GmbH

Global Compliance

Jakob-Dieffenbacher-Str. 12

75031 Eppingen, Germany

Phone: +49-7262-92 49 0

Email: [info@shure.de](mailto:info@shure.de)

[www.shure.com](http://www.shure.com)

---

## Important Product Information

### LICENSING INFORMATION

Licensing: A ministerial license to operate this equipment may be required in certain areas. Consult your national authority for possible requirements. Changes or modifications not expressly approved by Shure Incorporated could void your authority to operate the equipment. Licensing of Shure wireless microphone equipment is the user's responsibility, and licensability depends on the user's classification and application, and on the selected frequency. Shure strongly urges the user to contact the appropriate telecommunications authority concerning proper licensing, and before choosing and ordering frequencies.

**NOTE:** This Radio equipment is intended for use in musical professional entertainment and similar applications. This Radio apparatus may be capable of operating on some frequencies not authorized in your region. Please contact your national authority to obtain information on authorized frequencies and RF power levels for wireless microphone products.

---

## PA805SWB -- Passive Directional Antenna

---

### General Description

## SHURE PA805 DIRECTIONAL ANTENNA

The Shure PA805 is a directional antenna for increased range and reduced interference as compared to omnidirectional 1/2-wave antennas.

The PA805 can be mounted on a microphone stand or mounted to a wall using the integral swivel adapter bracket.

**NOTE:** Using too many transmission antennas in one installation can reduce performance. To combine PSM antennas, use a PA821 Antenna Combiner.

---

### Installation Instructions

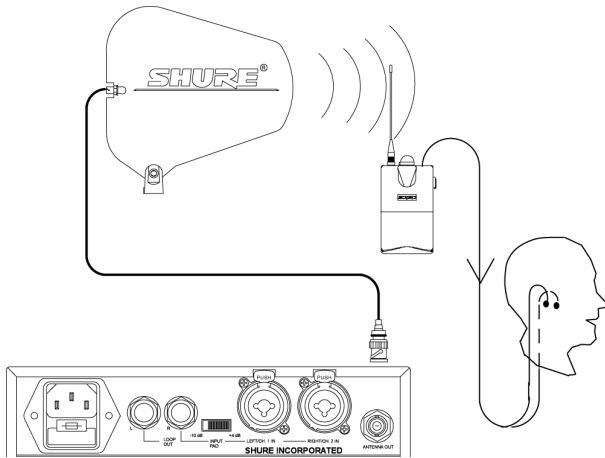

1. Determine the length of cable required to connect the PA805 Antenna to the Wireless Transmitter or Antenna Combiner. Use only as long a cable as necessary, because there is more power loss with longer cables. Always use low-loss 50 ohm cable, such as RG-8X or equivalent. Shure UA825 7.6 m (25 ft.) or UA850 15.2 m (50 ft.) cables are recommended.
2. Connect one end of the antenna cable to the PA805. Then mount the antenna so that it points toward the intended coverage area.
3. Connect the other end of the antenna cable to the ANTENNA OUT of the Wireless Transmitter or Antenna Combiner.  
Always perform a "walk around" test to verify coverage before using a wireless system during a speech or performance. Experiment with antenna placement to find the optimum location for the PA805.

## Cable Selection

Cable	Length	Type	Loss at 650 MHz
PA725	3.0 m (10 ft)	RG-58/U	1.4 dB
UA825	7.6 m (25 ft)	RG-8/X	2.8 dB
UA850	15.2 m (50 ft)	RG-8/X	5.6 dB

For additional technical assistance, call the Shure Customer Service Department.

## Specifications

### Antenna Gain

PA805X	6dBi typical
PA805SWB	6.5dBi typical
3 dB Beam Width	100 degrees

### Radiation Pattern

Directional; Cardioid

### Connector

50 W, Female, BNC-type

### Swivel Adapter

Positive-action, break resistant, adjustable from 0 to 90 degrees, with standard 5/8 in. -27 thread

### Frequency Range



<b>Model</b>	<b>RF Frequency Range (MHz)</b>	<b>Dimensions (with mounting accessories)</b>	<b>Net Weight (without cable)</b>
PA805SWB	470-952	334 mm H 378 mm W 27.9 mm D (13.15 in. H 14.88 in. W 1.10 in. D)	11.3 oz (319 grams) with mounting accessories
PA805X	944-952	226 mm H 234 mm W 27.9 mm D (8.90 in. H 9.21 in. W 1.10 in. D)	8 oz. (227 grams)

## Optional Accessories

25 ft. BNC-BNC Coaxial Cable	UA825
50 ft. BNC-BNC Coaxial Cable	UA850
PSM Antenna Combiner	PA821



# SM57

## Instrument Microphone

Manual for the Shure SM57 unidirectional dynamic microphone  
Version: 3.3 (2024-F)

---

# Table of Contents

<b>SM57 Instrument Microphone</b>	<b>3</b>	<b>SM57 Specifications</b>	<b>4</b>
		Diagrams	5
<b>General Description</b>	<b>3</b>	<b>Accessories</b>	<b>6</b>
<b>Placement</b>	<b>3</b>	Furnished Accessories	7
General Rules for Use	3	Optional Accessories	7
Avoiding Pickup of Unwanted Sound Sources	4	Replacement Parts	8
Proximity Effect	4	<b>Certifications</b>	<b>8</b>

# SM57

## Instrument Microphone

### General Description

The Shure SM57 unidirectional dynamic microphone is exceptional for musical instrument pickup or for vocals. With its bright, clean sound and carefully contoured presence rise, the SM57 is ideal for live sound reinforcement and recording. It has an extremely effective cardioid pickup pattern which isolates the main sound source while minimizing background noise. In the studio, it is excellent for recording drums, guitar, and woodwinds. For musical instruments or vocals, the SM57 is a consistent choice of professional performers.

### Placement

#### General Rules for Use

- Aim the microphone toward the desired sound source (such as the talker, singer, or instrument) and away from unwanted sources.
- Place the microphone as close as practical to the desired sound source.
- Work close to the microphone for extra bass response.
- Use only one microphone to pick up a single sound source.
- Use the fewest number of microphones as practical.
- Keep the distance between microphones at least three times the distance from each microphone to its source.
- Place microphones as far as possible from reflective surfaces.
- Add a windscreen when using the microphone outdoors.
- Avoid excessive handling to minimize pickup of mechanical noise and vibration.
- Do not cover any part of the microphone grille with your hand, as this will adversely affect microphone performance.

**Note:** The grille on top of the microphone should rotate freely. This is part of the design and does *not* mean the grille is broken. In certain applications (such as close-miking drums) an audible rattle might occur. A windscreen or a very small piece of foam wedged under the grille can eliminate this problem, but do not apply tape or otherwise cover or block the grille vents, as this disrupts the directionality of the microphone. Please visit the Shure website for more information.

The following table lists the most common applications and placement techniques. Keep in mind that microphone technique is largely a matter of personal taste; there is no one "correct" microphone position.

APPLICATION	SUGGESTED MICROPHONE PLACEMENT	TONE QUALITY
<b>Tom-Toms</b>	One mic on each tom, or between each pair of toms, 2.5 to 7.5 cm (1 to 3 in.) above drum heads. Aim each microphone at top drum heads. On double head toms, you can also remove bottom head and place a mic inside pointing up toward top drum head.	Medium attack; full, balanced sound.
<b>Snare Drum</b>	2.5 to 7.5 cm (1 to 3 in.) above rim of top head of drum. Aim mic at drum head. If desired, place a second mic just below rim of bottom head.	Most "snap" from drumstick. More "snare" sound.

APPLICATION	SUGGESTED MICROPHONE PLACEMENT	STONE QUALITY
<b>Guitar &amp; Bass Amplifiers</b>	2.5 cm (1 in.) from speaker, on-axis with center of speaker cone.	Sharp attack; emphasized bass.
	<b>2.5 cm (1 in.) from speaker, at edge of speaker cone.</b>	Sharp attack; higher frequency sound.
	<b>15 to 30 cm (6 to 12 in.) away from speaker and on-axis with speaker cone.</b>	Medium attack; full, balanced sound.
	<b>60 to 90 cm (2 to 3 ft.) back from speaker, on-axis with speaker cone.</b>	Softer attack; reduced bass.
<b>Vocals</b>	Lips less than 15 cm (6 in.) away or touching the windscreen, on axis to microphone.	Robust sound, emphasized bass, maximum isolation from other sources.

## Avoiding Pickup of Unwanted Sound Sources

Place the microphone so that unwanted sound sources, such as monitors and loudspeakers, are directly behind it. To minimize feedback and ensure optimum rejection of unwanted sound, always test microphone placement before a performance.

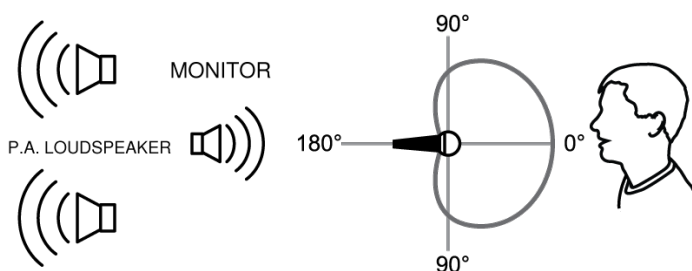

**Recommended Loudspeaker Locations for Cardioid Microphones**

## Proximity Effect

Unidirectional (cardioid) microphones progressively boost bass frequencies by 6 to 10 dB below 100 Hz when the microphone is at a distance of about 6 mm (1/4 in.) from the sound source. This phenomenon, known as proximity effect, can be used to create a warmer, more powerful sound. To prevent explosive low frequency sound during close-up use, the bass response gradually rolls off. This provides greater control and helps the user take advantage of proximity effect.

## SM57 Specifications

### Type

Dynamic (moving coil)

### Frequency Response

40 to 15,000 Hz

## Polar Pattern

Cardioid

## Output Impedance

310  $\Omega$

## Sensitivity

(@ 1 kHz, open circuit voltage)

-56.0 dBV/Pa[1] (1.6 mV)

## Polarity

Positive pressure on diaphragm produces positive voltage on pin 2 with respect to pin 3

## Net Weight

0.284 kg (0.625 lbs)

## Connector

Three-pin professional audio (XLR), male

## Housing

Dark gray, enamel-painted, die-cast steel with a polycarbonate grille and a stainless steel screen.

[1] 1 Pa=94 dB SPL

## Diagrams

### Typical Shure SM57 Frequency Response

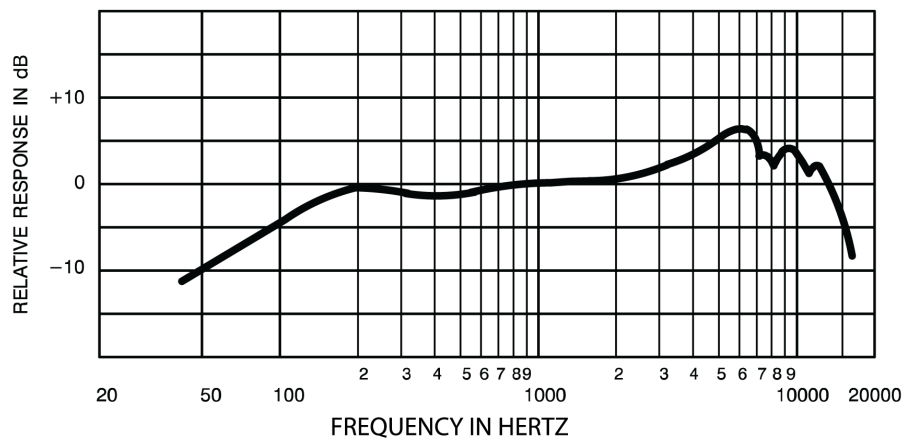

## Typical Shure SM57 Polar Patterns

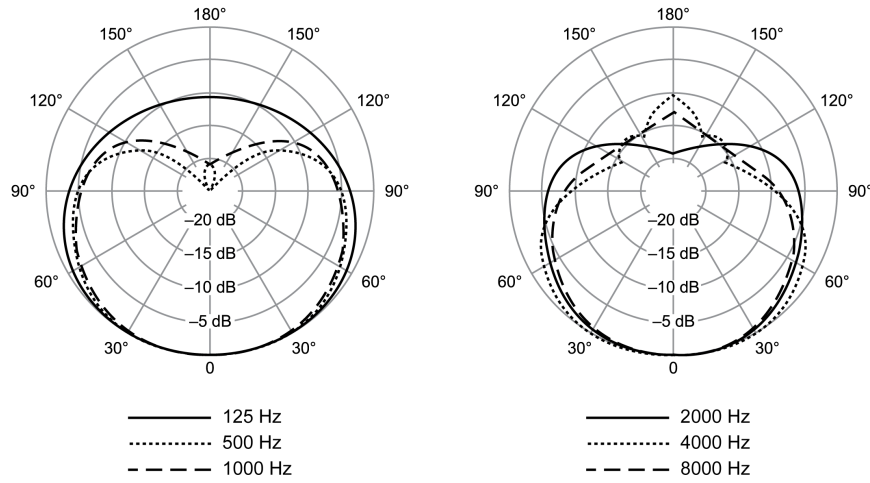

## SM57 Dimensions

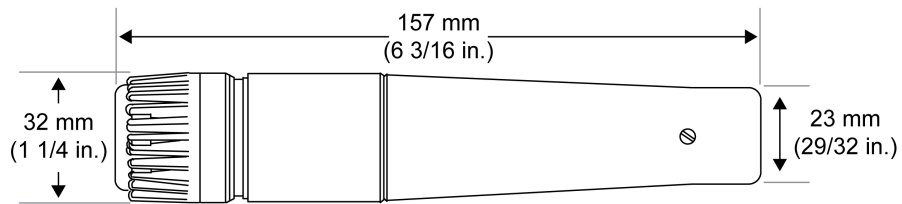

## Internal Connections

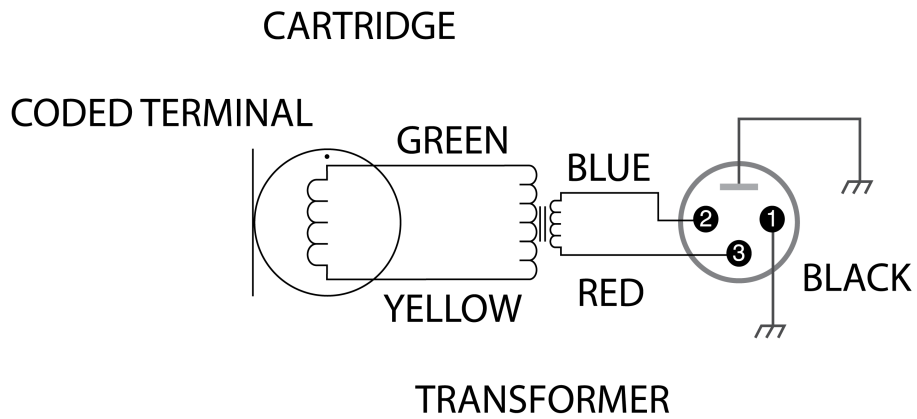

# Accessories

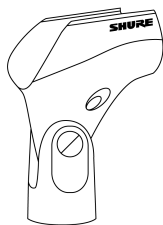

Microphone Clip



Zippered Carrying Bag

## Furnished Accessories

Microphone Clip for SM58, SM57, SM87A, BETA87A, BETA87C, PGA57, PGA58, PGA48, PGA81	A25D
Carrying/Storage Bag	95A2313

## Optional Accessories

Gray Locking Foam Windscreen for 545 Series, SM57	A2WS-GRA
Desk Stand	S37A
Shock Stopper <sup>®</sup> Isolation Mount	A55M
Over/Under Dual Mount for two microphones: SM57, BETA57A or 545 Series microphones	A26M
25 foot (7.5m) Triple-Flex <sup>®</sup> Microphone XLR Cable with Switchcraft connectors	C25E
25 foot (7.5m) Triple-Flex Microphone XLR Cable with chrome connectors	C25F



## Replacement Parts

<b>Grille for Shure SM57 and 545SD</b>	RK244G
<b>Cartridge for SM56 and SM57</b>	R57

---

## Certifications

This product meets the Essential Requirements of all relevant European directives and is eligible for CE marking.

The CE Declaration of Conformity can be obtained from: [www.shure.com/europe/compliance](http://www.shure.com/europe/compliance)

Authorized European representative:

Shure Europe GmbH

Global Compliance

Jakob-Dieffenbacher-Str. 12

75031 Eppingen, Germany

Phone: +49-7262-92 49 0

Email: [info@shure.de](mailto:info@shure.de)

[www.shure.com](http://www.shure.com)

### MODEL SM81 UNIDIRECTIONAL CONDENSER MICROPHONE



#### OVERVIEW

The Shure Model SM81 is a high-quality, unidirectional condenser microphone designed for studio recording, broadcasting, and sound reinforcement. Its wide frequency response, low noise characteristics, and low RF susceptibility have made it a standard for applications involving acoustic instruments, especially guitar, piano, and cymbals.

#### FEATURES

- 20 Hz to 20 kHz frequency response
- Flat response curve for accurate reproduction of sound sources
- Low noise and high output clipping level
- Low distortion over a wide range of load impedances
- Cardioid polar pattern, uniform with frequency and symmetric about axis, providing maximum rejection and minimum coloration of off-axis sounds

#### SPECIFICATIONS

##### Type

Condenser (electret bias)

##### Frequency Response

20 to 20,000 Hz

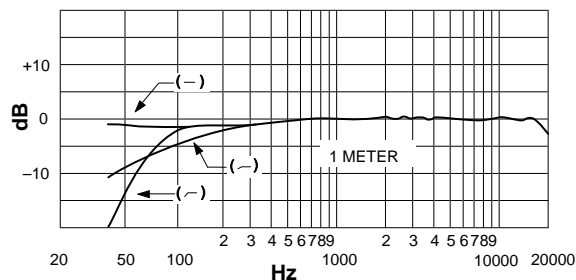

TYPICAL FREQUENCY RESPONSE

The SM81 is ruggedly constructed. It operates on phantom power and performs over a wide range of temperatures and humidity conditions. It is furnished with a swivel adapter, attenuator-switch lock, foam windscreen, and case for carrying and storage. Other accessories are available.

- Low RF susceptibility
- Selectable low-frequency response: flat, 6 or 18 dB/octave rolloff
- 0 dB/10 dB lockable attenuator switch
- Phantom powering (DIN 45 596 voltages of 12 to 48 Vdc)
- Rugged steel construction for durability
- Field-usable over wide range of temperature and humidity conditions

##### Polar Pattern

Cardioid (unidirectional) response—uniform with frequency, symmetrical about axis (see Figure NO TAG)

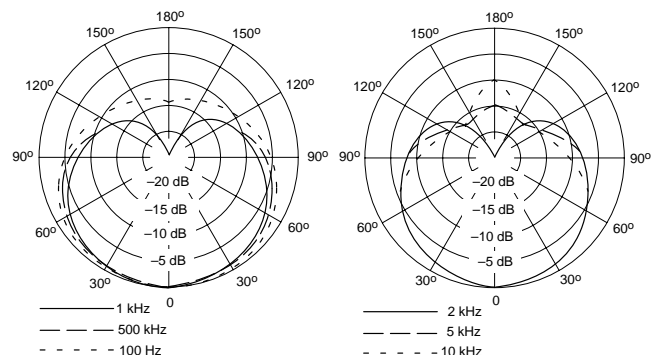

TYPICAL POLAR PATTERNS

**Output Impedance**

Rated at 150 ohms (85  $\Omega$  actual)  
 Recommended minimum load impedance: 800  $\Omega$  (May be used with loads as low as 150  $\Omega$  with reduced clipping level)

**Output Configuration and Connector**

Balanced, transformer-coupled output; male XLR connector

**Sensitivity (at 1,000 Hz)**

Open Circuit Voltage . . . . . -45 dBV/Pascal (5.6 mV)  
 (1 Pascal = 94 dB SPL)

**Clipping Level (at 1,000 Hz)**

800  $\Omega$  Load . . . . . -4 dBV (0.63 V)  
 150  $\Omega$  Load . . . . . -15 dBV (0.18 V)

**Total Harmonic Distortion**

Less than 0.5% (131 dB SPL at 250 Hz into 800  $\Omega$  load)

**Maximum SPL (at 1,000 Hz)**

800  $\Omega$  load . . . . . 136 dB (attenuator at 0)  
 146 dB (attenuator at -10)  
 150  $\Omega$  load . . . . . 128 dB (attenuator at 0)  
 138 dB (attenuator at -10)

**Hum Pickup**

-3 dB equivalent SPL in a 1 mOe field (60 Hz)

**Self-Noise** (equivalent sound pressure levels; measured with true rms voltmeter)

16 dB typical, A-weighted  
 19 dB typical, weighted per DIN 45 405

**Signal-to-Noise Ratio**

78 dB (IEC 651)\* at 94 dB SPL  
 \*S/N ratio is difference between microphone output at 94 dB SPL and microphone self-noise A-weighted.

**Overvoltage and Reverse Polarity Protection**

Max. external voltage applied to pins 2 and 3 with respect to pin 1 . . . . . + 52 Vdc

**FURNISHED ACCESSORIES**

Swivel Adapter . . . . . A57F  
 10 dB Attenuator Lock . . . . . 34A830

**REPLACEMENT PARTS**

Cartridge and Grille Assembly . . . . . R104

**OPTIONAL ACCESSORIES**

Pop-Filter Grille . . . . . A81G  
 Heavy-Duty Windscreen . . . . . A81WS  
 Tripod Microphone Stand (4.3 m [14 ft]) . . . . . S15A

Reverse polarity protection . . . . . 200 mA max.  
 (diode-clamped)

**Polarity**

Positive pressure on diaphragm produces positive voltage on pin 2 relative to pin 3

**Cartridge Capacitance**

54 pF

**Low Frequency Response Switch Positions**

Flat; -6 dB/octave below 100 Hz; -18 dB/octave below 80 Hz

**Attenuator Switch Positions (Lockable)**

0 or -10 dB

**Power**

Supply Voltage . . . 11 to 52 Vdc, positive, pins 2 and 3  
 Current Drain . . . . . 1.2 mA max.

**Environmental Conditions**

Temperature:  
 Storage . . . . . -29° to 74° C  
 (-20° to 165° F)  
 Operating . . . . . -6.7° to 49° C  
 (20° to 120° F)

Humidity:  
 Storage . . . . . 0-95% relative humidity at room temperature (72° to 80° F, 22° to 27° C)

**Case**

Steel construction with vinyl metallic paint finish and stainless steel screens

**Dimensions**

See Figure NO TAG

**Weight**

Net . . . . . 230 grams (8 oz)  
 Packaged . . . . . 740 grams (1 lb 10 oz)

Carrying/Storage Case . . . . . 65A1797  
 Windscreen . . . . . 49A111

Stereo Microphone Adapter . . . . . A27M  
 Cable (7.6m [25ft]) . . . . . C25F  
 Phantom Power Supply . . . . . PS1A

# Product Specifications

## Beta® 98A Miniature Cardioid Condenser Microphone

### Overview

The Shure Beta 98A miniature cardioid condenser microphones are precision-engineered for professional drum and instrument in live and studio applications. The Beta 98AD/C is designed for use with toms, snares and percussion instruments in both sound reinforcement and recording applications. A flexible gooseneck mount allows for accurate placement in any configuration, customization for specific applications. The Beta 98A/C features a highly compact design which provides a variety of placement options for acoustic or amplified instruments including drums, piano, reed, wind, and strings.

### Features

- Uniform cardioid polar pattern provides maximum gain-before-feedback and rejection of off-axis sound for smooth high-end response and control
- Frequency response tailored for drums and percussion applications with a wide dynamic range for use in high SPL environments
- Precision-engineered design for unobtrusive microphone footprint
- Beta 98A models ship with external in-line preamplifier for discrete cable placement
- Beta 98AD/C ships with A98D Drum mount featuring a flexible gooseneck for precise placement and secure attachment
- Beta 98A/C ships with RK282 shock mount swivel adapter for attachment to any standard microphone stand
- Each model furnished with snap-fit windscreens and zipper pouch

### Available Models

<b>BETA 98AD/C</b>	Miniature Cardioid Condenser Drum Microphone
<b>BETA 98A/C</b>	Miniature Cardioid Condenser Microphone

### Specifications

Cartridge Type	Electret Condenser
Frequency Response	20 to 20,000 Hz
Polar Pattern	Cardioid
Output Impedance	179 Ω
Sensitivity <i>(at 1 kHz, open circuit voltage)</i>	-48.0 dBV/Pa (4.0 mV)
Maximum SPL <i>(1 kHz at 1% THD, 1kΩ load)</i>	144 dB
Signal-to-Noise Ratio <i>(referenced at 94 dB SPL at 1 kHz)</i>	64 dB <i>S/N ratio is difference between 94 dB SPL and equivalent SPL of self noise, A-weighted</i>
Dynamic Range <i>(at 1 kHz, 1kΩ load)</i>	114 dB
Clipping Level <i>(1 kHz at 0.25% THD, 1kΩ load)</i>	1.0 dBV (1.26 V)
Self-Noise <i>(Typical, equivalent SPL, A-weighted)</i>	30 dB SPL
Polarity	Positive pressure on diaphragm produces positive voltage on pin 2 with respect to pin 3
Weight	Net: 12 g (0.6 oz.)
Connector	Three-pin professional audio (XLR), male, balanced
Power Requirements	11–52 VDC phantom power (IEC-61938), 3.6 mA



Beta 98AD/C



Beta 98A/C

### Accessories and Replacement Parts

<b>RPM626</b>	In-Line Preamplifier	<b>95A2314</b>	Carrying/Storage Bag
<b>A98D</b>	Beta 98 Drum Mount (98D/S)	<b>C98D</b>	4.6 m (15 ft.) Heavy-Duty Cable (BETA 98D/S)
<b>RK282</b>	Shock-Mount Swivel Adapter (98D/S)	<b>95A2398</b>	7.6 m (25 ft.) light-weight cable (BETA 98/S)
<b>RK183WS</b>	Snap-fit Windscreens		

### Polar Pattern

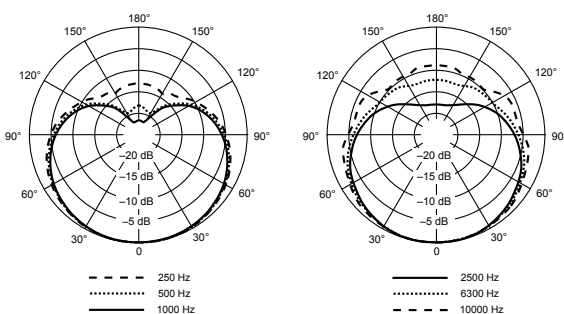

### Frequency Response

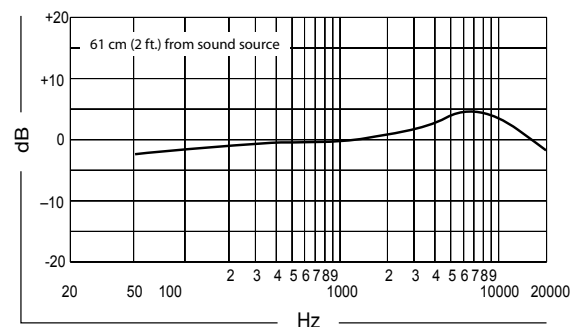

**SHURE**  
LEGENDARY  
PERFORMANCE™

www.shure.com

©2015 Shure Incorporated

# Product Specifications

## Beta® 52A Supercardioid Dynamic Kick Drum Microphone

### Overview

The Shure Beta 52A is a precision-engineered dynamic microphone with a tailored frequency response and integrated swivel-mount with XLR connector designed specifically for kick drums and other bass instruments. It provides superb attack and “punch,” and delivers studio quality sound even at extremely high sound pressure levels.

### Features

- Premier live performance microphone with Shure quality, ruggedness, and reliability
- Modified supercardioid pick-up pattern for maximum gain before feedback and superior rejection of off-axis sound
- Tailored frequency response specifically shaped for kick drums and bass instruments
- Neodymium magnet for greater sensitivity and higher output
- Advanced pneumatic shock mount system that minimizes transmission of mechanical noise and vibration
- Dent-resistant, steel mesh grille and enamel coated die-cast metal construction resist wear and abuse
- Studio quality performance, even at high SPL
- Built-in stand adapter with dynamic locking system and XLR connector simplifies setup and provides greater flexibility



Beta 52A

### Available Models

<b>BETA 52A</b>	Supercardioid Swivel-mount Dynamic Kick Drum Microphone with high-output Neodymium Element
-----------------	--

### Specifications

Cartridge Type	Dynamic (moving coil)
Frequency Response	20 to 10,000 Hz
Polar Pattern	Supercardioid
Output Impedance	150 Ω
Sensitivity <i>(at 1kHz, open circuit voltage)</i>	-64 dBV/Pa (0.6 mV) 1 Pascal=94 dB SPL
Maximum SPL <i>(1 kHz at 1% THD, 1kΩ load)</i>	174 dB
Polarity	Positive pressure on diaphragm produces positive voltage on pin 2 with respect to pin 3
Weight	Net: 0.605 kg (1.35 lbs)
Connector	Three-pin professional audio (XLR), male
Case	134 dB (159 dB, -25 Pad)

### Accessories and Replacement Parts

<b>RK321</b>	Replacement grille	<b>R175</b>	Replacement cartridge
--------------	--------------------	-------------	-----------------------

#### Polar Pattern

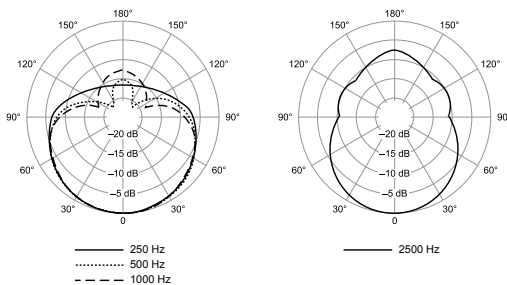

#### Frequency Response

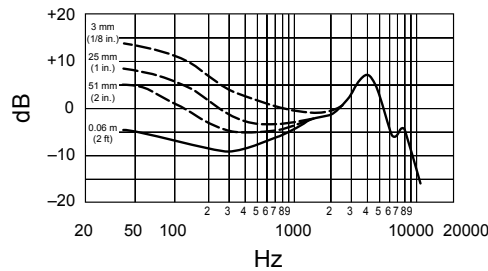

**SHURE**<sup>®</sup>  
LEGENDARY  
PERFORMANCE™

www.shure.com

©2015 Shure Incorporated

**On-Stage®**

## 50' 16-CHANNEL/4-RETURN STAGE SNAKE

**Model:** SNK16450V2

**UPC:** 659814141401



- 100% OFC wiring increases conductivity and resists corrosion for strong transmission
- Hand-soldered, individually insulated XLR connectors prevent short circuits
- Heavy-duty stage box protects internal components to ensure reliable operation
- Wire-mesh strain relief prevents excessive flexing near the connectors

[Buy Now](#)

### PRODUCT PROPERTIES

<b>Application</b>	Live sound	<b>Construction</b>	Metal	<b>Product Type</b>	Cable
<b>Color</b>	Black	<b>Includes</b>	Nylon bag	<b>XLR Inputs</b>	16 (female)
		<b>Length</b>	50'	<b>XLR Outputs</b>	4 (male)

### DESCRIPTION:

Our SNK16450v2 50' 16-Channel/4-Return Stage Snake neatly bundles 16 XLR channels from a stage or studio to a mixer and four XLR returns to stage monitors or headphones, eliminating the need to run multiple long cables. For secure, efficient set up and teardown, quick-release connectors lock in connections yet easily disconnect with the push of a button. OFC wiring increases conductivity and resists corrosion while hand-soldered, individually insulated connectors prevent short circuits. Flexible cable bundling with strain relief and a heavy-duty stage box protect internal components to ensure reliable operation. The built-in box handle facilitates ergonomic carrying.

**On-Stage**

## 100' 16-CHANNEL/4-RETURN STAGE SNAKE

**Model:** SNK164100V2

**UPC:** 659814141395



- 100% OFC wiring increases conductivity and resists corrosion for strong transmission
- Hand-soldered, individually insulated XLR connectors prevent short circuits
- Heavy-duty stage box protects internal components to ensure reliable operation
- Wire-mesh strain relief prevents excessive flexing near the connectors

[Buy Now](#)

### PRODUCT PROPERTIES

Application	Live sound	Construction	Metal	Product Type	Cable
Color	Black	Includes	Nylon bag	XLR Inputs	16 (female)
		Length	100'	XLR Outputs	4 (male)

### DESCRIPTION:

Our SNK164100V2 100' 16-Channel/4-Return Stage Snake neatly bundles 16 XLR channels from a stage or studio to a mixer and four XLR returns to stage monitors or headphones, eliminating the need to run multiple long cables. For secure, efficient set up and teardown, quick-release connectors lock in connections yet easily disconnect with the push of a button. OFC wiring increases conductivity and resists corrosion while hand-soldered, individually insulated connectors prevent short circuits. Flexible cable bundling with strain relief and a heavy-duty stage box protect internal components to ensure reliable operation. The built-in box handle facilitates ergonomic carrying.

# CN-15MP & CN-20MP

Contractor Series MiniPorts



**CN-15MP**  
(shown without Phoenix-type connectors and security cover)



**CN-20MP**  
(shown with Phoenix-type connectors and security cover)

## Features

- Provides AC control for equipment located away from system racks with primary power conditioners/sequencers (i.e. powered speakers).
- Sequencing of duplex initiated remotely by standard analog triggering (remote terminal) or digital link (SmartSequencing from CN-1800S or CN-2400S).
- SmartSequencing Technology allows multiple units to be daisy chained at runs of over 1,000' between units with bi-directional communications between units for sequencing on and off large and/or complex systems.
- IP Control (Telnet or cloud-based BlueBOLT) via SmartSequencing (when connected to CN-1800S/ CN-2400S with BB-RS232 Adaptor).
- Remote terminal supports connections to legacy Furman (non-Contractor Series) and third party power sequencers for maximum installation flexibility.
- DIP switches and potentiometer allows customization of settings such as sequencing delays, 12V on/off, and more.
- Extreme Voltage Shutdown (EVS) safeguards from catastrophic under-voltage (under 80V sustained) or over-voltage (over 145V sustained) conditions. Circuit may be set to auto-reset when voltage returns to normal or manual reset after an event is detected.
- Security covers prevent unauthorized personnel from tampering with DIP switches.
- Fire alarm shut off.
- Available with 15 amp capacity (**CN-15MP**) or 20 amp capacity (**CN-20MP**).
- Safety agency listed (CSA).
- 15 Year Limited Product Warranty. See warranty policy documentation for terms and conditions.



- Potentiometer for Fine Tune Delay Time
- DIP switches for configuring settings
- Bypass switch overrides relay for troubleshooting or in event of control system failure

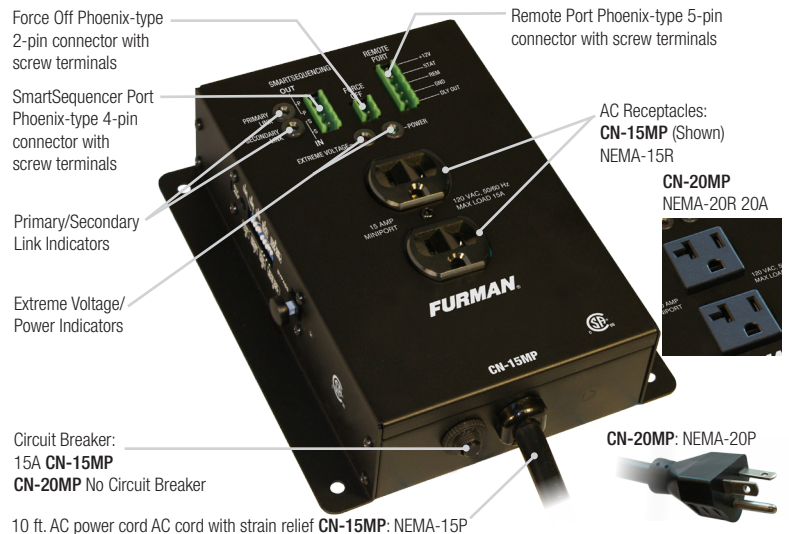



## Specifications

### AC Voltage Input Range

90-139VAC, 50/60Hz

### Maximum AC Current Rating

**CN-15MP:** 15 Amps (Thermal breaker)

**CN-20MP:** 20 Amps

### AC Cord:

**CN-15MP:** 3/14AWG, 10 feet, black, fixed, NEMA 5-15P plug

**CN-20MP:** 3/12 AWG, 10 feet, black, fixed, NEMA 5-20P plug

### AC Receptacles:

**CN-15MP:** 2 NEMA 5-15R's (1 duplex)

**CN-20MP:** 2 NEMA 5-20R's (1 duplex)

### Under-Overvoltage Protection:

AC Undervoltage Protection: EVS, 77VAC+/-3VAC

AC Overvoltage Protection: EVS, 140VAC+/-5VAC

EVS Enable/Disable (configurable)

### Operating Temperature Range:

5C (40F) to 40C (105F) degrees

### Humidity Range:

<90% rH (Relative Humidity)

### User Interface:

Circuit Breaker: Pushbutton, 15A (**CN-15MP**),

20A (**CN-20MP**) No Breaker

Front panel diagnostic indicators (LED): Power, Extreme Voltage, Primary Link, Secondary Link

### User Interface (continued):

Side Panel DIP Switches: Side panel, hidden by security cover, 1 Minute Delay, 2 Minute Delay, 4 Minute Delay, Force Off NO/NC, 12V Mode On/Off GND Mode On, Momentary/Maintained, Primary/Secondary, EVS Reset Auto/Manual  
 Potentiometer: Side panel, hidden by security cover, fine tune delay adjust

### Control/Status/Triggering (Top Panel):

Remote Terminal: +5-30VDC In, 12VDC (12mA) Out

SmartSequencing: Phoenix 4-Pin Connector, Screw Terminals, Primary & Secondary Links (Current Loop - 1000' nominal)

Remote Terminal: Phoenix 5-Pin Connector With Screw Terminals;

+12V, STAT, REM, GND, DLY OUT(Class 2 Wiring)

Force Off: Phoenix-type 2-Pin Connector With Screw Terminals,

FORCE OFF: (Class 2 Wiring)

IP Addressability: Optional, via CN-1800S or CN-2400S with BB-RS232

Ethernet/RS-232

Adaptor (sold separately) for IP control via Telnet, HTTP, BlueBOLT®

Voltmeter: Available via SmartSequencing communication, +/- 2VAC accuracy

Ammeter: Available via SmartSequencing communication, +/-1A accuracy

### Power Consumption (No Load): 10 Watts

### Safety Agency: CSA

### RoHS Compliant: Yes



Specifications subject to change due to product upgrades and improvements.

## Dimensions and Weight

Common FRONT dimensions for both **CN-15MP** and **CN-20MP**

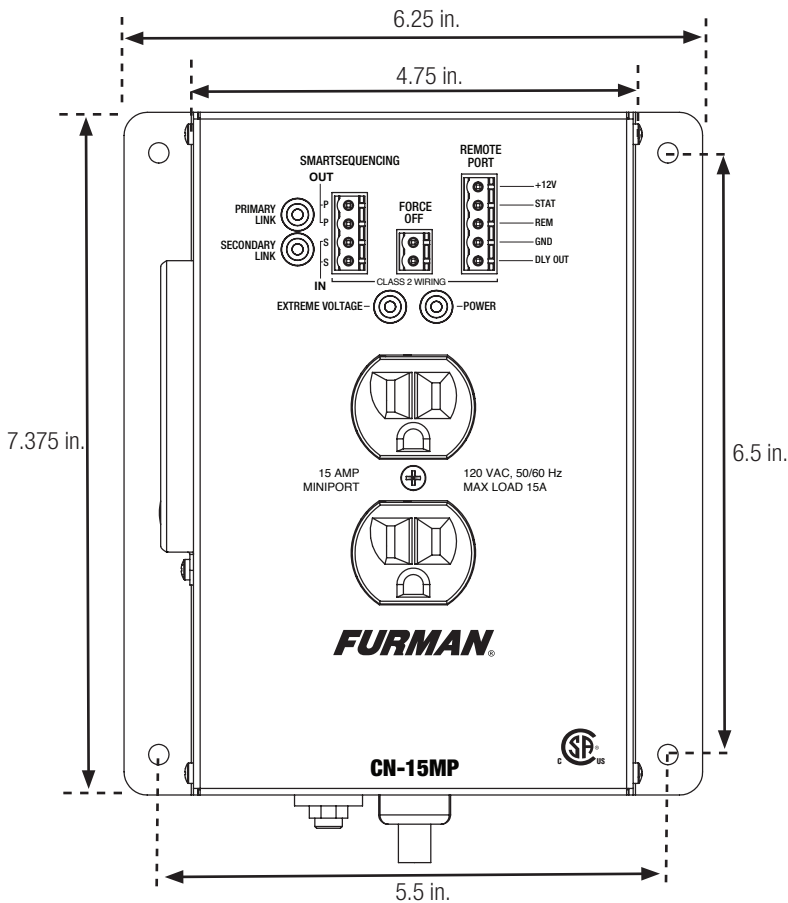

Unit Weight: 3.75 lbs. (both models)

SIDE **CN-15MP**

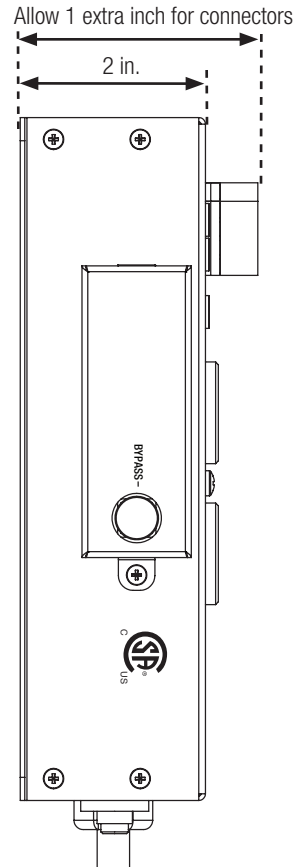

Power Cord-10 feet, black, fixed, NEMA  
 • (CN-15MP) 3/14AWG, 5-15P plug

SIDE **CN-20MP**

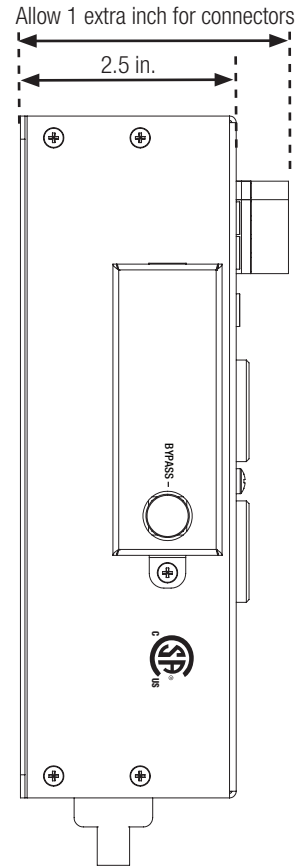

Power Cord-10 feet, black, fixed, NEMA  
 • (CN-20MP) 3/12AWG, 5-20P plug

# CN-1800S & CN-2400S

## Contractor Series SmartSequencers



Furman's SmartSequencers combines AC power distribution, protection, filtration, and sequential system power on/off in a 1RU, 120VAC, rack-mount unit.

### Features

- SmartSequencing technology allows large and complex A/V systems to be safely powered on and off with a simple press of a button or turn of a key, even by non-technical personnel.
- Multiple units may be daisy chained at runs of over 1,000' between units with bi-directional communications between units for sequencing on and off large and/or complex systems.
- RS-232 compatibility and command set provide integration with control systems, optional RS-232-to-Ethernet adaptor allows for control, programming, & monitoring from any Web-enabled device via Telnet, direct HTTP connection, or Panamax/Furman's BlueBOLT® platform.
- Series Multi-Stage Protection (SMP) ensures zero downtime for mission-critical installations by safely absorbing, clamping and dissipating transient surges and spikes without damage to internal circuitry or connected equipment.
- Extreme Voltage Shutdown (EVS) safeguards from catastrophic under-voltage (under 80V sustained) or over-voltage (over 145V sustained) conditions. Circuit may be set to auto-reset when voltage returns to normal or manual reset after an event is detected.
- Linear Filtering Technology (LiFT) ensures maximum performance from connected equipment by reducing AC noise evenly across the audio & video bandwidth.
- Security covers and sequence on/off keyswitch prevent unauthorized personnel from running/shutting down system or tampering with DIP switches.
- Fire alarm shut off.
- Available with 15 amp capacity (CN-1800S) or 20 amp capacity (CN-2400S).
- 15 Year Limited Product Warranty. See warranty policy documentation for terms and conditions.



### Front Panel

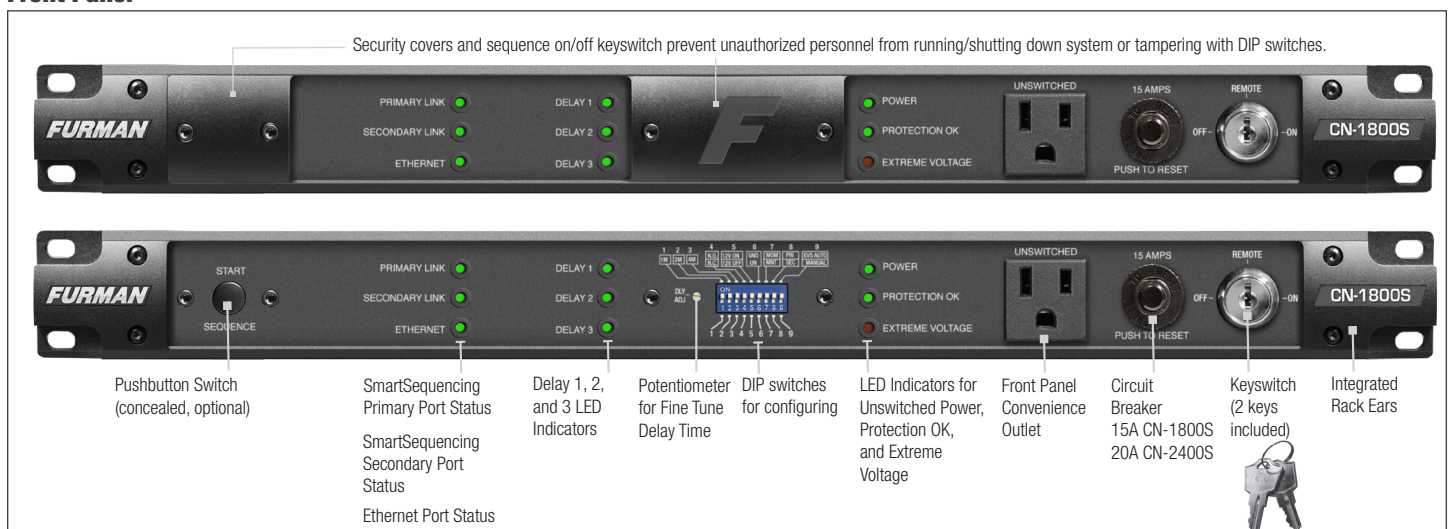

# CN-1800S & CN-2400S Contractor Series SmartSequencers

## Rear Panel

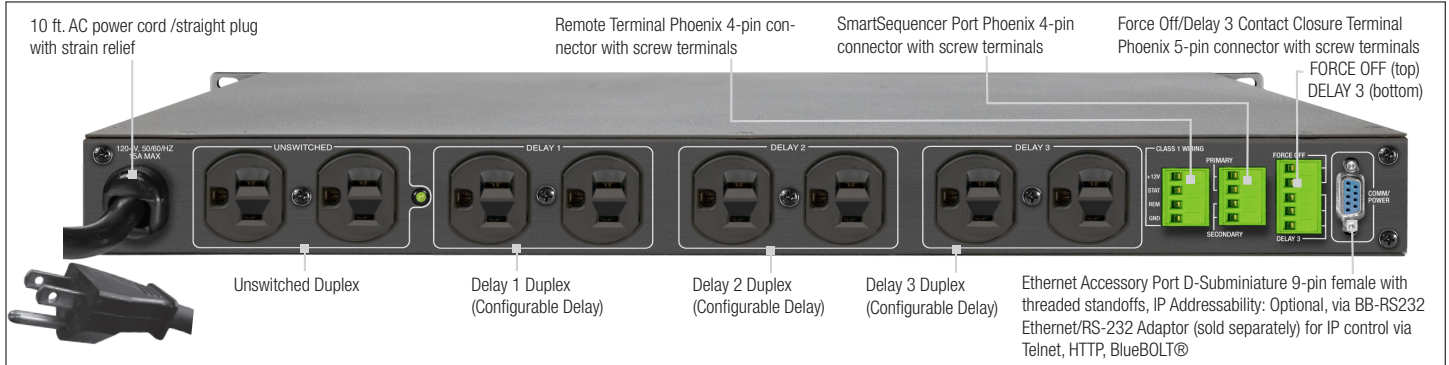

## Specifications

### AC Voltage Input Range

90-139VAC, 50/60Hz

### Maximum AC Current Rating

CN-1800S: 15 amps (Thermal breaker)  
CN-2400S: 20 amps (Thermal breaker)

### AC Cord:

CN-1800S: 3/14AWG, 10 feet, black, fixed, NEMA 5-15P plug  
CN-2400S: 3/12 AWG, 10 feet, black, fixed, NEMA 5-20P plug

### AC Receptacles:

Convenience Outlet (Front Panel) 1 Unswitched NEMA 5-15R  
CN-1800S Rear Panel Outlets: 2 Unswitched NEMA 5 15R's (1 duplex),  
6 Sequenced NEMA 5-15R's (3 duplexes each controlled by separate relay)  
CN-2400S Rear Panel Outlets: 2 Unswitched NEMA 5 20R's (1 duplex),  
6 Sequenced NEMA 5-20R's (3 duplexes each controlled by separate relay)

### Surge/Under-Overvoltage Protection:

AC Surge Protection: SMP  
Spike Protection Mode: Line to neutral, zero ground leakage  
Spike Clamping Voltage: 188VAC peak @ 6,000 volts/3,000 amps  
Response Time: 1 nanosecond  
Maximum Surge Current: 6,500 Amps  
AC Undervoltage Protection: EVS, 77VAC+/- 3VAC  
AC Overvoltage Protection: EVS, 145VAC+/- 5VAC  
AC Overvoltage Reset Modes: Manual and Auto-reset (configurable)

### AC Filtering:

LI FT  
Noise Attenuation: Linear, 10dB @10KHz, 40dB@100KHz, 50dB@500KHz

### Operating Temperature Range:

5C (40F) to 40C (105F) degrees

### Humidity Range:

<90% rH (Relative Humidity)

### User Interface:

Keyswitch: Front panel, 3-position keyswitch (On, Off, Remote)  
Keys: Included, 1 pair  
Pushbutton Switch: Front panel, hidden by security cover  
Circuit Breaker: Front panel, pushbutton, 15A (CN-1800S), 20A (CN-2400S) Thermal Breaker  
Front panel diagnostic indicators: Primary link, Secondary link, Ethernet, Remote off, Delay 1, Delay 2, Delay 3, Power, Protection OK, Extreme Voltage  
Front Panel DIP Switches: Front panel, hidden by security cover, 1 Minute Delay, 2 Minute Delay, 4 Minute Delay,  
Force Off NO/NC, 12V Mode On/Off GND Mode On, Momentary/Maintained, Primary/Secondary, EVS Reset Auto/Manual  
Potentiometer: Front panel, hidden by security cover, fine tune delay adjust

### Control/Status/Triggering (Rear Panel):

Remote Terminal: +5-30VDC In, 12VDC (12mA) Out  
SmartSequencing: Phoenix 4-Pin Connector, Screw Terminals, Primary & Secondary Links (Current Loop - 1000' nominal)  
Remote Terminal: Phoenix 4-Pin Connector With Screw Terminals; +12V, STAT, REM, GND (Class 2 Wiring)  
Force Off/Delay 3 Terminal: Phoenix 5-Pin Connector With Screw Terminals, FORCE OFF, DELAY 3 (Class 2 Wiring)  
RS-232 Compatible: Yes, DB-9 Connector  
IP Addressability: Optional, via BB-RS232 Ethernet/RS-232 Adaptor (sold separately) for IP control via Telnet, HTTP, BlueBOLT®  
Voltmeter: Available with RS-232/Ethernet option, +/- 2VAC accuracy  
Ammeter: Available with RS-232/Ethernet option, +/-1A accuracy

### Power Consumption (No Load): 10 Watts

### Safety Agency: NRTL-C

### RoHS Compliant: Yes



Specifications subject to change due to product upgrades and improvements.

## Dimensions and Weight

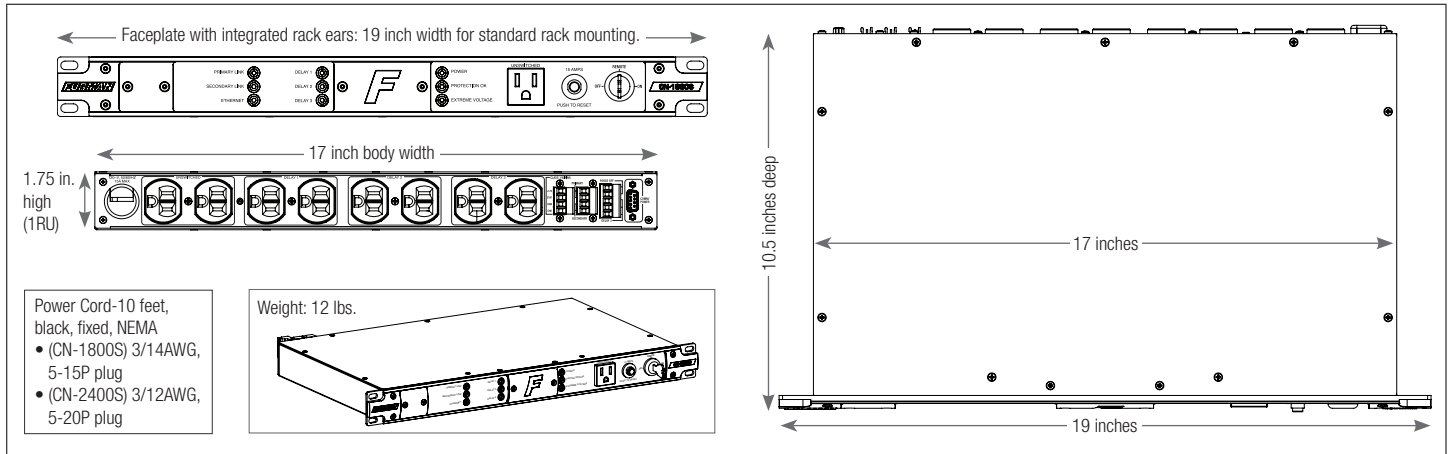

Power Cord-10 feet, black, fixed, NEMA  
• (CN-1800S) 3/14AWG, 5-15P plug  
• (CN-2400S) 3/12AWG, 5-20P plug

Weight: 12 lbs.

## AC Relay Accessory

MODEL PS-REL (FOR USE WITH PS-8R, PS-PRO, POWERPORT AND MINIPOINTS)

## Instruction Sheet

### About the PS-REL

The PS-REL AC Relay Accessory is designed primarily for use with the PS-8R 15 amp Power Sequencer, the PS-PRO 20 amp Power Sequencer, the PowerPort 20 amp Remote AC Controller, the MiniPort-30 Power Relay (30 amps), MiniPort-20 Power Relay (rated 20 amps), and the MiniPort-15 Power Relay (rated 15 amps).

The PS-REL is simply a small box containing a relay. It functions as a sensor which can close a switch in response to the presence of AC power.

The PS-REL is needed whenever a PS-8R, PS-PRO, PowerPort or MiniPort (or linked chain of PowerPorts or MiniPorts) must be turned on in response to energizing a switched outlet. This occurs frequently in "home theater" installations when a switched outlet on a preamp or receiver, often activated by a wireless remote device, is to be used to power up a large amount of equipment. It allows multiple 15-amp and 20-amp circuits to be controlled from one device.

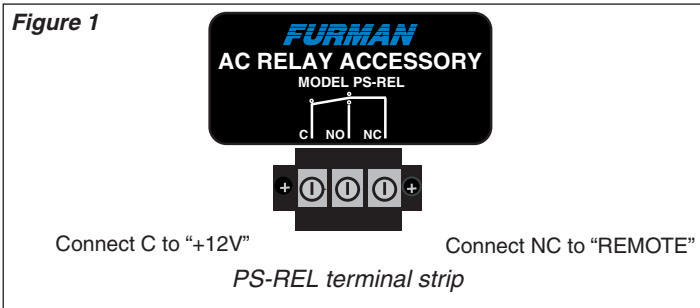

The PS-REL has a two-prong AC plug on a 6-foot cord to activate the relay, and three terminals that connect to the relay contacts (Fig. 1). There is a common contact labeled (C), a normally open contact (NO), and a normally closed contact (NC). It should be noted that when connecting the PS-REL to any Furman sequenced power product that (C) should be connected to the (+12V) terminal, and that (NC) should be connected to the (REM) terminal.

When the relay opens, the device will turn on. Two wires should be connected to the +12V and REM IN screw terminals of the PS-8R, PS-PRO, PowerPort, or MiniPorts. The PS-REL's AC cord should be plugged into the outlet to be sensed.

The PS-REL AC Relay Accessory may also be used: (1) To allow a PS-8R or PS-PRO to be hooked up to another PS-8R or PS-PRO to provide six separate delayed turn on/turn off groups, by having the relay sense the presence of power at the Delay 3 outlet, (2) To turn on a single PowerPort or a chain of PowerPorts linked together; (3) To turn on a MiniPort or a chain of MiniPorts linked together.

When AC power appears at the sensed outlet, the PS-8R, PS-PRO, PowerPort (or linked chain of PowerPorts), or MiniPort (or linked chain of MiniPorts) will begin its turn-on sequence.

**Figure 2**

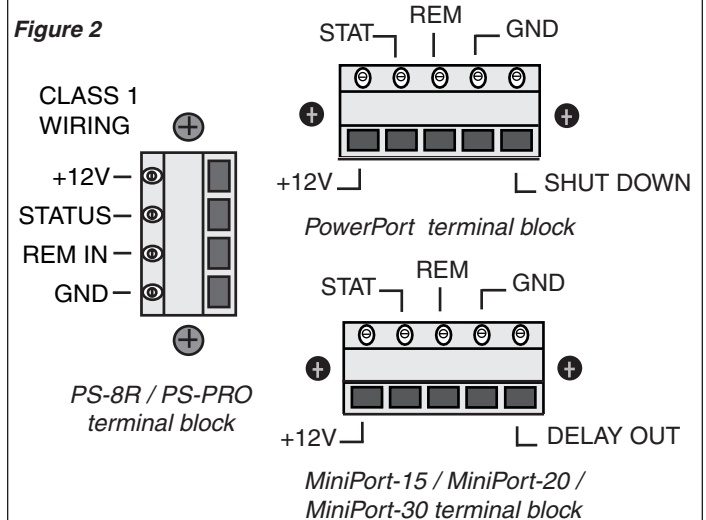

### Limited Warranty

The Furman PS-REL is warranted against failures due to defective parts or faulty workmanship for a period of three years after delivery to the original owner. During this period, Furman will make any necessary repairs without charge for parts or labor. Shipping charges to the factory or repair station must be prepaid by the owner; return shipping charges (via UPS Ground) will be paid by Furman.

This warranty applies only to the original owner and is not transferable. Also, it does not apply to repairs done other than by the Furman factory or Authorized Repair Stations.

This warranty may be cancelled by Furman at its sole discretion if the PS-REL unit has been subjected to physical abuse or has been modified in any way without written authorization from Furman. Furman's liability under this warranty is limited to repair or replacement of the defective unit.

Furman will not be responsible for incidental or consequential damage resulting from the use or misuse of its products. Some states do not allow the exclusion of incidental or consequential damages, so the above limitations may not apply to you. This warranty gives you specific legal rights, and you may also have other rights which vary from state to state.

Warranty claims should be accompanied by a copy of the original purchase invoice showing the purchase date (if a Warranty Registration Card was mailed in at the time of purchase, this is not necessary). Before returning any equipment for repair, please read the important information on service, which follows.

### Service

Before returning any equipment for repair, please be sure that it is adequately packed and cushioned against damage in shipment, and that it is insured. We suggest that you save the original packaging and use it to ship the product for servicing. Also, please enclose a note giving your name, address, phone number and a description of the problem.

NOTE: All equipment being returned for repair must have a Return Authorization (R/A) Number. To get an R/A Number, please call the Furman Service Department, (707) 763-1010, ext. 121, between 8 am and 5 pm U.S. Pacific Time. Please display your R/A Number prominently on the front of all packages.

Contact us for More Information

We'll send you our full-line color catalog and a detailed data sheet on any Furman product. And be sure to visit our website at <http://www.furmansound.com>





SECTION I

PROPOSAL

WILLINGBORO TOWNSHIP  
PERFORMANCE ARTS CENTER  
SOUND AND LIGHTING SYSTEM EQUIPMENT  
PROJECT NO. WTCEX 21015

TO: THE TOWNSHIP OF WILLINGBORO

The undersigned hereby declares that he/she/they has/have carefully examined the specifications, plans and form of contract for the project named above; that he/she they has/have carefully examined the site of the project; and that he/she/they will contract to carry out and complete said project as specified and delineated at the price per unit measure for each scheduled item of work stated in the Schedule of Prices following.

It is understood that the Total Price for the entire contract stated by the undersigned in the Schedule is based on the estimated quantities and will control in the awarding of the contract. It is further understood that the quantities stated in this Schedule of Prices for the various items are estimated only and may be increased or decreased. Payment will be made only for the actual quantity of authorized work done under each scheduled item.

It is further understood that the following procedure will be used to correct numerical discrepancies found in the Schedule of Prices following:

1. All Unit Prices and the Total Price for the entire contract shall be expressed in both words and figures, and in case of discrepancy, the written price shall govern over the price stated in figures.
2. If based on the above, it is found that the written Total Price for the entire contract is found to have been incorrectly computed, then changes will be made in any or all unit prices so as to attain conformity with said Total Price before the contract is executed.

The undersigned proposes to furnish all labor, materials and equipment required to construct and complete the structures and do other work complete in every detail, in accordance with plans, specifications and other contract documents prepared by Pennoni Associates Inc., Consulting Engineers, at and for the following Lump Sum Prices and Unit Prices:





TOWNSHIP OF WILLINGBORO  
 PERFORMING ARTS CENTER  
 SOUND AND LIGHTING SYSTEM EQUIPMENT  
 CONTRACT NO. WTCEX 21015

AUDIO:

Bid Item	Description	Manufacturer	Manufacturer Part Number	Qty	Unit Price	Total Price
1	Speaker	RCF	GTX10	12	_____	_____
Total Price (written) _____						dollars and _____ cents
2	Speaker	RCF	GTS29	4	_____	_____
Total Price (written) _____						dollars and _____ cents
3	Flybar	RCF	FL-B 006	3	_____	_____
Total Price (written) _____						dollars and _____ cents
4	Power Amp	RCF	XPS-16K-D	3	_____	_____
Total Price (written) _____						dollars and _____ cents
5	Audio Console	Midas	HD96-24-CC-IP	1	_____	_____
Total Price (written) _____						dollars and _____ cents
6	I/O Preamp Stage Box	Midas	DL231	3	_____	_____
Total Price (written) _____						dollars and _____ cents



Bid Item	Description	Manufacturer	Manufacturer Part Number	Qty	Unit Price	Total Price
7	I/O Preamp Stage Box	Midas	DL152	1	_____	_____
Total Price (written) _____ dollars and _____ cents						
8	Audio Console	Midas	Heritage D HD96	1	_____	_____
Total Price (written) _____ dollars and _____ cents						
9	I/O Stage Box	Midas	DL231	3	_____	_____
Total Price (written) _____ dollars and _____ cents						
10	I/O Stage Box	Midas	DL152	1	_____	_____
Total Price (written) _____ dollars and _____ cents						
11	AES50 Extender	Klark Teknik	DN9680	1	_____	_____
Total Price (written) _____ dollars and _____ cents						
12	Speaker	RCF	NX12-SM	12	_____	_____
Total Price (written) _____ dollars and _____ cents						



Bid Item	Description	Manufacturer	Manufacturer Part Number	Qty	Unit Price	Total Price
13	Wireless Microphone Receiver	Shure	ULXD4Q	2	_____	_____
Total Price (written) _____ dollars and _____ cents						
14	Wireless Microphone	Shure	ULXD2/SM58	8	_____	_____
Total Price (written) _____ dollars and _____ cents						
15	Antenna Splitter	Shure	UA844	1	_____	_____
Total Price (written) _____ dollars and _____ cents						
16	Antenna Paddle	Shure	PA805SWB	2	_____	_____
Total Price (written) _____ dollars and _____ cents						
17	Microphone	Shure	Beta 152	1	_____	_____
Total Price (written) _____ dollars and _____ cents						
18	Microphone	Shure	SM57	4	_____	_____
Total Price (written) _____ dollars and _____ cents						



Bid Item	Description	Manufacturer	Manufacturer Part Number	Qty	Unit Price	Total Price
19	Microphone	Shure	SM98	4	_____	_____
	Total Price (written)				_____ dollars and _____ cents	
20	Microphone	Shure	SM81	3	_____	_____
	Total Price (written)				_____ dollars and _____ cents	
21	Equipment Rack, 4 Drawers	Mid Atlantic	N/A	1	_____	_____
	Total Price (written)				_____ dollars and _____ cents	
22	XLR Stage Snake	OnStage	N/A	5	_____	_____
	Total Price (written)				_____ dollars and _____ cents	
23	Cable Package: (24) 10ft XLR Cables, (32) 25ft XLR Cables, (8) 50ft XLR Cables, (16) 20ft Quarter to Quarter Instrument Cable, (1) 15ft 8ch Fan to Fan Quarter Inch Snake, (24) 10ft XLR Cables	OnStage	N/A	1	_____	_____
	Total Price (written)				_____ dollars and _____ cents	
24	Mic Stand Package: (8) Straight round Base Mic Stand, (8) Tripod boom mic stand, (5) Drum Mic mount, (4) Short tripod Stand with boom, (2) Round base short mic stand with boom	OnStage	N/A	1	_____	_____
	Total Price (written)				_____ dollars and _____ cents	





Bid Item	Description	Manufacturer	Manufacturer Part Number	Qty	Unit Price	Total Price
25	Power Sequencing	Furman	CN-20MP	10	_____	_____
Total Price (written) _____ dollars and _____ cents						
26	Power Sequencing	Furman	CN-18008	1	_____	_____
Total Price (written) _____ dollars and _____ cents						
27	Power Sequencing	Furman	PS-REL-AC	10	_____	_____
Total Price (written) _____ dollars and _____ cents						

**LIGHTING:**

Bid Item	Description	Manufacturer	Manufacturer Part Number	Qty	Unit Price	Total Price
28	Lighting Controller	Obsidian	NX2	1	_____	_____
Total Price (written) _____ dollars and _____ cents						
29	Bolt Truss 12"x12" 10ft Sections	Gamma		4	_____	_____
Total Price (written) _____ dollars and _____ cents						
30	Light Fixture	Cameo	CLP2T	12	_____	_____
Total Price (written) _____ dollars and _____ cents						



Bid Item	Description	Manufacturer	Manufacturer Part Number	Qty	Unit Price	Total Price
31	Light Fixture Lens	Cameo	CLP21530 LENS	12	_____	_____
Total Price (written) _____ dollars and _____ cents						
32	Light Fixture	Cameo	Theatre Spot 200	6	_____	_____
Total Price (written) _____ dollars and _____ cents						
33	Light Fixture	Cameo	Azor S2 / CLAZOR	8	_____	_____
Total Price (written) _____ dollars and _____ cents						
34	Light Fixture	Chauvet Pro	Color-dash Par H18X	3	_____	_____
Total Price (written) _____ dollars and _____ cents						
35	Hazer	Cameo	Instant haze 1400 Pro	2	_____	_____
Total Price (written) _____ dollars and _____ cents						
<del>36</del>	<del>Cable Package</del>	<del>N/A</del>	<del>N/A</del>	<del>1</del>	<del>_____</del>	<del>_____</del>
<del>Total Price (written) _____ dollars and _____ cents</del>						



Bid Item	Description	Manufacturer	Manufacturer Part Number	Qty	Unit Price	Total Price
37	Power Sequencing	Furman	CN-20MP	10	_____	_____
Total Price (written) _____ dollars and _____ cents						
38	Power Sequencing	Furman	CN-1800S	1	_____	_____
Total Price (written) _____ dollars and _____ cents						
39	Power Sequencing	Furman	PS-REL AC	10	_____	_____
Total Price (written) _____ dollars and _____ cents						
40	Stage Lighting Spigot Truss System	Gamma	GT-SQ290	16	_____	_____
Total Price (written) _____ dollars and _____ cents						
41	Stage Lighting Truss System	Gamma	G-Truss Ground	4	_____	_____
Total Price (written) _____ dollars and _____ cents						



TOTAL BASE BID

Contract WTCEX 21015: Sound and Lighting System Equipment  
Items 1-41

\_\_\_\_\_ Dollars

and \_\_\_\_\_ Cents                      \$ \_\_\_\_\_

All Base Contract items must be bid.

The Owner reserves the right to award the contract to the lowest responsive, responsible bidder based on the Base Bid.





PROPOSAL (Continued)

The undersigned hereby agrees to complete all work within the number of calendar days listed below from the date of notice to begin work, which will be forwarded to the Contractor by the ENGINEER. Contractor further agrees that the OWNER may, without recourse or other legal action, retain from the monies that are or may become due the amount stipulated below for each and every calendar day (Sundays and legal holidays excepted) that the completion of the work may be delayed beyond the time stipulated below. Such amount is hereby mutually agreed, not as a penalty, but as liquidated damages accruing to the OWNER due to such delay for extra costs due to engineering or other expenses. The schedule of completion dates and amount for liquidated damages are as follows:

<u>CONTRACT</u>	<u>CALENDAR DAYS TO COMPLETE</u>	<u>LIQUIDATED DAMAGES</u>
Contract No. WTCEX 21015		\$100.00/Day
Base Bid	45 Days	Base Bid and/or alternate(s)

There is enclosed herewith the required bid security (Cashier's Check, certified check, or bid bond) to the order of the TOWNSHIP OF WILLINGBORO in the sum of \_\_\_\_\_ Dollars (\$ \_\_\_\_\_), and a duly executed consent from an approved surety company, licensed to conduct business in the State of New Jersey, agreeing to furnish the required bond upon the award of contract.

Name and business address of bidder to whom all formal notices are to be sent:

---

---

---

---

---



PROPOSAL (Continued)

CONTRACT NO. WTCEX 21015 CONTRACTOR

The undersigned offers the following information relative to the facilities, ability and financial resources available for the fulfillment of the contract if such be awarded to him.

FACILITIES: That he or they own and have available for immediate use on the proposed work the following plant and equipment:

\_\_\_\_\_  
NOT APPLICABLE  
\_\_\_\_\_  
\_\_\_\_\_  
\_\_\_\_\_  
\_\_\_\_\_

ABILITY: That he or they have performed the following work: (Give location, kind, size or cost and reference to name and address of client or ENGINEER.)

\_\_\_\_\_  
(LIST UNDER "STATEMENT OF QUALIFICATIONS")  
\_\_\_\_\_  
NOT APPLICABLE  
\_\_\_\_\_  
\_\_\_\_\_

FINANCIAL RESOURCES: That information relative to his or their financial resources can and may be obtained from the following: (Give name, business and address.)

\_\_\_\_\_  
NOT APPLICABLE  
\_\_\_\_\_  
\_\_\_\_\_  
\_\_\_\_\_  
\_\_\_\_\_



PROPOSAL (Continued)

CONTRACT NO. WTCEX 21015 SUBCONTRACTOR

The undersigned offers the following information relative to the facilities, ability and financial resources available for the fulfillment of the contract if such be awarded to him.

FACILITIES: That he or they own and have available for immediate use on the proposed work the following plant and equipment:

\_\_\_\_\_  
NOT APPLICABLE  
\_\_\_\_\_  
\_\_\_\_\_  
\_\_\_\_\_

ABILITY: That he or they have performed the following work: (Give location, kind, size or cost and reference to name and address of client or ENGINEER.)

\_\_\_\_\_  
(LIST UNDER "STATEMENT OF QUALIFICATIONS")  
\_\_\_\_\_  
NOT APPLICABLE  
\_\_\_\_\_  
\_\_\_\_\_

FINANCIAL RESOURCES: That information relative to his or their financial resources can and may be obtained from the following: (Give name, business and address.)

\_\_\_\_\_  
NOT APPLICABLE  
\_\_\_\_\_  
\_\_\_\_\_  
\_\_\_\_\_

SUBCONTRACTOR: List Name, Address and Telephone Number:

\_\_\_\_\_  
\_\_\_\_\_  
\_\_\_\_\_



PROPOSAL (Continued)

CONTRACT NO. WTCEX 21015 INSTALLER QUALIFICATIONS

The projects listed below have been constructed by the bidder or persons to be in responsible charge of this project.

REFERENCES

<u>Date of Completion</u>	<u>Owner &amp; Contact No.</u>	<u>Location</u>	<u>Engineer &amp; Contact No.</u>
1.	NOT APPLICABLE		
2.			
3.			
4.			
5.			
6.			
7.			
8.			
9.			
10.			

The bidder attests to the fact that he or the subcontractor has crews trained and expert in the construction of the type specified.





PROPOSAL (Continued)

The undersigned states that the names and addresses of persons interested as principals in this Proposal are as follows:

(Write first name in full):

_____	_____
_____	_____
_____	_____
_____	_____
_____	_____

If a partnership or corporation, give the names of all partners, or all officers of the corporation with the addresses of each:

_____	_____
_____	_____
_____	_____
_____	_____
_____	_____

ADDENDA:

The bidder acknowledges the receipt of Addenda enumerated below which have been issued subsequent to the original advertisement date and agrees that said Addenda shall become a part of this Contract.

ADDENDUM NO.

ISSUING DATE

_____	_____
_____	_____
_____	_____



PROPOSAL (Continued)

Upon request the bidder will be expected to amplify the foregoing statements as necessary to satisfy the OWNER concerning his ability to successfully perform the work in a satisfactory manner.

The undersigned bidder submitting this proposal or bid certifies and affirms that such bid is genuine and not collusive or sham; that said bidder has not colluded, conspired, connived, or agreed, directly or indirectly, with any bidder or person, to put in a sham bid, or that such other persons shall refrain from bidding, and has not in any manner, directly or indirectly, sought by agreement or collusion, or communication or conference, with any person, to fix the bid price of said bidder or any other bidder or fix any overhead, profit or cost element of said bid price, or that of any other bidder, or to secure any advantage against the OWNER or any person interested in the proposed contract; and further, that such bidder has not, directly or indirectly, submitted this bid, or the contents thereof, or divulged information or data relative thereto any association or to any member or agent thereof; and, that no member of the OWNER's Officials or Employees of said OWNER is interested directly or indirectly in the bid or in any portion of the bid, nor in the Contract or in any part of the Contract which may be awarded the undersigned on the basis of such bid.

Signed this \_\_\_\_\_ day of \_\_\_\_\_, 20\_\_\_\_\_.

\_\_\_\_\_  
Bidder

By \_\_\_\_\_  
(Signature of Individual, Partner, or  
Officer Signing the Proposal)

(SEAL)

(Seal is required if Bidder  
is a corporation)

\_\_\_\_\_  
Title



PROPOSAL (Continued)

BIDDER'S AFFIDAVIT

STATE OF \_\_\_\_\_ )

COUNTY OF \_\_\_\_\_ )

\_\_\_\_\_

being duly sworn, deposes and says that he resides at

\_\_\_\_\_

and that he is the \_\_\_\_\_  
(Give Title)

of \_\_\_\_\_

who signed the above Proposal or Bid, that he was duly authorized to sign and that the Bid is the true offer of the Bidder, that the seal attached is the seal of the Bidder and that all declarations and statements contained in the Bid are true to the best of his knowledge and belief.

He further deposes that he has submitted herewith a list of names and addresses of all stockholders and/or partners owning a 10 percent or greater interest therein in compliance with P.L. 1977, Chapter 33, effective March 8, 1977.

\_\_\_\_\_ Affiant \_\_\_\_\_

Subscribed and Sworn to before me this \_\_\_\_\_ day  
of \_\_\_\_\_, 20\_\_\_\_\_.



PROPOSAL (Continued)

DATE: \_\_\_\_\_, 20\_\_\_\_  
OWNER: TOWNSHIP OF WILLINGBORO  
CONTRACT NO(S).: WTCEX 21015  
CONTRACT TITLE(S): PAC SOUND AND LIGHTING EQUIPMENT

AFFIRMATIVE ACTION QUESTIONNAIRE  
AND INFORMATION FORM FOR  
CONSTRUCTION CONTRACTS

1.01 Please complete the following questions. In the event that your firm is awarded the Contract(s), this information will be used to provide your office with the necessary forms and will serve as a check list to insure that all required documentation is submitted.

1.02 DO NOT submit any documentation or complete any forms at this time. ONLY answer the questions and sign the certification.

=====

1. Does your firm have existing federally approved or sanctioned affirmative action program?

Yes      No

A. If YES, a photostatic copy of this approval will be required to be submitted to the Public Agency.

2. If your answer to Question No. 1 is NO, you will be required to submit a completed Project Manning Report, Form AA201-A (Building Construction or Form AA201-B (Heavy Construction). You will be required to distribute the copies as designated on the Form (2-Affirmative Action Office, 1-Public Agency, 1-retained by Contractor.

A. For construction projects with a total construction cost of less than \$50,000, the Project Manning Report will not be required except when requested by the Affirmative Action Office.

3. Subcontractors with four (4) or fewer employees are exempt from the requirements of Questions 1 and 2.





PROPOSAL (Continued)

1.03 Submission Schedule: If, a prior to or at the time the Public Agency submits a contract for signing, a Contractor does not submit evidence of an existing federally approved or sanctioned Affirmative Action Program, then no later than three (3) calendar days after Contractor signs the contract, the Contractor shall submit the required documentation. All documentation required by the Public Agency shall be submitted to the ENGINEER. All documentation required to be submitted to the State Affirmative Action Office shall be submitted directly to them.

1.04 The purpose of this questionnaire and information form is to provide general guidance to the Contractor. All responsibility for complying with the Affirmative Action Regulations (P.L. 1975, c. 127) rests solely with the Contractor.

1.05 I certify that all the above information is correct to the best of my knowledge.

NAME: \_\_\_\_\_

SIGNATURE: \_\_\_\_\_

TITLE: \_\_\_\_\_

DATE: \_\_\_\_\_



PROPOSAL (Continued)

NON-COLLUSION AFFIDAVIT

STATE OF NEW JERSEY  
COUNTY OF \_\_\_\_\_

I, \_\_\_\_\_ of the City of \_\_\_\_\_  
in the County of \_\_\_\_\_ and the State of \_\_\_\_\_ of  
full age, being duly sworn according to law on my oath depose and say that:

I am \_\_\_\_\_ of the firm of \_\_\_\_\_  
\_\_\_\_\_

the bidder making the Proposal for the above named project, and that I executed the said Proposal with full authority so to do; that said bidder has not, directly or indirectly, entered into any agreement, participated in any collusion, or otherwise taken any action in restraint of free, competitive bidding in connection with the above named project; and that all statements contained in said Proposal and in this affidavit are true and correct, and made with full knowledge that the OWNER relies upon the truth of the statements contained in said proposal and in the Statements contained in this affidavit in awarding the contract for the said project.

I further warrant that no person or selling agency has been employed or retained to solicit or secure such contract upon an agreement or understanding for a commission, percentage, brokerage or contingent fee, except bona fide employees or bona fide established commercial or selling agencies maintained by

\_\_\_\_\_  
(Name of Contractor) (N.J.S.A.52:34-15)

\_\_\_\_\_  
(Also type or print name of  
affiant under signature)

Subscribed and sworn before me this  
\_\_\_\_\_ day of \_\_\_\_\_, 20 \_\_\_\_\_

\_\_\_\_\_  
Notary Public of

My Commission Expires \_\_\_\_\_



PROPOSAL (Continued)

RETURN OF BID SECURITY

If bid security is returned at bid meeting, bidder or his representative must sign receipt below:

TO: THE TOWNSHIP OF WILLINGBORO  
PROJECT: PAC SOUND AND LIGHTING SYSTEM EQUIPMENT  
CONTRACT NO.: WTCEX 21015

I hereby acknowledge return of bid security submitted this date for the project noted above.

\_\_\_\_\_ Date \_\_\_\_\_ Bidder

By \_\_\_\_\_

Bid Security Returns: ( ) Certified Check No. \_\_\_\_\_  
( ) Bid Bond \_\_\_\_\_  
( ) Cashier's Check No. \_\_\_\_\_

In the Amount of \_\_\_\_\_

All other bid securities will, at the appropriate time, be returned by CERTIFIED MAIL.



# ACKNOWLEDGEMENT OF RECEIPT OF CHANGES TO BID DOCUMENTS FORM

\_\_\_\_\_

(Name of Local Contracting Unit)

\_\_\_\_\_

(Name of Construction/Public Works Project)

\_\_\_\_\_

(Project or Bid Number)

Pursuant to N.J.S.A. 40A:11-23.1a., the undersigned bidder hereby acknowledges receipt of the following notices, revisions, or addenda to the bid advertisement, specifications or bid documents. By indicating date of receipt, bidder acknowledges the submitted bid takes into account the provisions of the notice, revision or addendum. Note that the local unit's record of notice to bidders shall take precedence and that failure to include provisions of changes in a bid proposal may be subject for rejection of the bid.

Local Unit Reference Number or Title of Addendum/Revision	How Received (mail, fax, pick-up, etc.)	Date Received

Acknowledgment by bidder:

Name of Bidder: \_\_\_\_\_

By Authorized Representative:

Signature: \_\_\_\_\_

Printed Name and Title: \_\_\_\_\_

Date: \_\_\_\_\_





## Disclosure of Investment Activities in Iran

**Person or Entity**

### Part 1: Certification

COMPLETE PART 1 BY CHECKING **EITHER BOX.**

Pursuant to Public Law 2012, c. 25, any person or entity that is a successful bidder or proposer, or otherwise proposes to enter into or renew a contract, must complete the certification below to attest, under penalty of perjury, that neither the person or entity, nor any parent entity, subsidiary, or affiliate is identified on the State Department of Treasury's Chapter 25 list as a person or entity engaging in investment activities in Iran. The list is found on Treasury's website at [www.state.nj.us/treasury/purchase/pdf/Chapter25List.pdf](http://www.state.nj.us/treasury/purchase/pdf/Chapter25List.pdf).

The Chapter 25 list must be reviewed prior to completing the below certification. If a vendor or contractor is found to be in violation of law, action may be taken as appropriate and as may provided by law, rule or contract, including but not limited to imposing sanctions, seeking compliance, recovering damages, declaring the party in default and seeking debarment or suspension of the party.

*I certify, pursuant to Public Law 2012, c. 25, that neither the person or entity listed above, nor any parent entity, subsidiary, or affiliate thereof is listed on the N.J. Department of the Treasury's list of entities determined to be engaged in prohibited activities in Iran pursuant to P.L. 2012, c. 25 ("Chapter 25 List"). I further certify that I am the person listed above, or I am an officer or representative of the entity listed above and am authorized to make this certification on its behalf. I will skip Part 2 and sign and complete the Certification below.*

**OR**

*I am unable to certify as above because the person or entity and/or a parent entity, subsidiary, or affiliate thereof is listed on the N.J. Department of the Treasury's Chapter 25 list. I will provide a detailed, accurate and precise description of the activities in Part 2 below sign and complete the Certification below.*



## Part 2: Additional Information

PLEASE PROVIDE FURTHER INFORMATION RELATED TO INVESTMENT ACTIVITIES IN IRAN.

You must provide a detailed, accurate and precise description of the activities of the person or entity, or a parent entity, subsidiary, or affiliate thereof engaging in investment activities in Iran below and, if more space is needed, on additional sheets provided by you.

## Part 3: Certification of True and Complete Information

*I, being duly sworn upon my oath, hereby represent and state that the foregoing information and any attachments there to the best of my knowledge are true and complete. I attest that I am authorized to execute this certification on behalf of the above-referenced person or entity.*

*I acknowledge that the **Township of Willingboro** is relying on the information contained herein and thereby acknowledge that I am under a continuing obligation from the date of this certification through the completion of any contracts with the **Township** to notify the **Township** in writing of any changes to the answers of information contained herein.*

*I acknowledge that I am aware that it is a criminal offense to make a false statement or misrepresentation in this certification, and if I do so, I recognize that I am subject to criminal prosecution under the law and that it will also constitute a material breach of my agreement(s) with the **Township of Willingboro** and that the **Township** at its option may declare any contract(s) resulting from this certification void and unenforceable.*

<b>Full Name (Print)</b>		<b>Title</b>	
<b>Signature</b>		<b>Date</b>	





## CERTIFICATION OF NON-INVOLVEMENT IN PROHIBITED ACTIVITIES IN RUSSIA OR BELARUS

Pursuant to N.J.S.A. 52:32-60.1, et seq. ([L. 2022, c. 3](#)) any person or entity (hereinafter "Vendor") that seeks to enter into or renew a contract with a State agency for the provision of goods or services, or the purchase of bonds or other obligations, must complete the certification below indicating whether or not the Vendor is identified on the Office of Foreign Assets Control (OFAC) Specially Designated Nationals and Blocked Persons list, available here: <https://sanctionssearch.ofac.treas.gov/>. If the Department of the Treasury finds that a Vendor has made a certification in violation of the law, it shall take any action as may be appropriate and provided by law, rule or contract, including but not limited to, imposing sanctions, seeking compliance, recovering damages, declaring the party in default and seeking debarment or suspension of the party.

I, the undersigned, certify that I have read the definition of "Vendor" below, and have reviewed the Office of Foreign Assets Control (OFAC) Specially Designated Nationals and Blocked Persons list, and having done so certify:

*(Check the Appropriate Box)*

A. That the Vendor is not identified on the [OFAC Specially Designated Nationals and Blocked Persons list on account of activity related to Russia and/or Belarus](#).

**OR**

B. That I am unable to certify as to "A" above, because the Vendor is identified on the [OFAC Specially Designated Nationals and Blocked Persons list on account of activity related to Russia and/or Belarus](#).

**OR**

C. That I am unable to certify as to "A" above, because the Vendor is identified on the [OFAC Specially Designated Nationals and Blocked Persons list](#). However, the Vendor is engaged in activity related to Russia and/or Belarus consistent with federal law, regulation, license or exemption. A detailed description of how the Vendor's activity related to Russia and/or Belarus is consistent with federal law is set forth below.

*(Attach Additional Sheets If Necessary.)*

Signature of Vendor's Authorized Representative

Date

Print Name and Title of Vendor's Authorized Representative

Vendor's FEIN

Vendor's Name

Vendor's Phone Number

Vendor's Address (Street Address)

Vendor's Fax Number

Vendor's Address (City/State/Zip Code)

Vendor's Email Address

<sup>1</sup> Vendor means: (1) A natural person, corporation, company, limited partnership, limited liability partnership, limited liability company, business association, sole proprietorship, joint venture, partnership, society, trust, or any other nongovernmental entity, organization, or group; (2) Any governmental entity or instrumentality of a government, including a multilateral development institution, as defined in Section 1701(c)(3) of the International Financial Institutions Act, 22 U.S.C. 262r(c)(3); or (3) Any parent, successor, subunit, direct or indirect subsidiary, or any entity under common ownership or control with, any entity described in paragraph (1) or (2).





**STATEMENT OF OWNERSHIP DISCLOSURE**

**N.J.S.A. 52:25-24.2 (P.L. 1977, c.33, as amended by P.L. 2016, c.43)**

This statement shall be completed, certified to, and included with all bid and proposal submissions. Failure to submit the required information is cause for automatic rejection of the bid or proposal.

**Name of**

**Organization:** \_\_\_\_\_

**Organization**

**Address:** \_\_\_\_\_

**Part I** Check the box that represents the type of business organization:

- Sole Proprietorship (skip Parts II and III, execute certification in Part IV)
- Non-Profit Corporation (skip Parts II and III, execute certification in Part IV)
- For-Profit Corporation (any type)    Limited Liability Company (LLC)
- Partnership    Limited Partnership    Limited Liability Partnership (LLP)
- Other (be specific): \_\_\_\_\_

**Part II**

- The list below contains the names and addresses of all stockholders in the corporation who own 10 percent or more of its stock, of any class, or of all individual partners in the partnership who own a 10 percent or greater interest therein, or of all members in the limited liability company who own a 10 percent or greater interest therein, as the case may be. (COMPLETE THE LIST BELOW IN THIS SECTION)

OR

- No one stockholder in the corporation owns 10 percent or more of its stock, of any class, or no individual partner in the partnership owns a 10 percent or greater interest therein, or no member in the limited liability company owns a 10 percent or greater interest therein, as the case may be. (SKIP TO PART IV)

(Please attach additional sheets if more space is needed):

Name of Individual or Business Entity	Home Address (for Individuals) or Business Address





**Part III DISCLOSURE OF 10% OR GREATER OWNERSHIP IN THE STOCKHOLDERS, PARTNERS OR LLC MEMBERS LISTED IN PART II**

If a bidder has a direct or indirect parent entity which is publicly traded, and any person holds a 10 percent or greater beneficial interest in the publicly traded parent entity as of the last annual federal Security and Exchange Commission (SEC) or foreign equivalent filing, ownership disclosure can be met by providing links to the website(s) containing the last annual filing(s) with the federal Securities and Exchange Commission (or foreign equivalent) that contain the name and address of each person holding a 10% or greater beneficial interest in the publicly traded parent entity, along with the relevant page numbers of the filing(s) that contain the information on each such person. Attach additional sheets if more space is needed.

Website (URL) containing the last annual SEC (or foreign equivalent) filing	Page #'s

Please list the names and addresses of each stockholder, partner or member owning a 10 percent or greater interest in any corresponding corporation, partnership and/or limited liability company (LLC) listed in Part II other than for any publicly traded parent entities referenced above. The disclosure shall be continued until names and addresses of every noncorporate stockholder, and individual partner, and member exceeding the 10 percent ownership criteria established pursuant to N.J.S.A. 52:25-24.2 has been listed. Attach additional sheets if more space is needed.

Stockholder/Partner/Member and Corresponding Entity Listed in Part II	Home Address (for Individuals) or Business Address

**Part IV Certification**

I, being duly sworn upon my oath, hereby represent that the foregoing information and any attachments thereto to the best of my knowledge are true and complete. I acknowledge: that I am authorized to execute this certification on behalf of the bidder/proposer; that the Township of Willingboro is relying on the information contained herein and that I am under a continuing obligation from the date of this certification through the completion of any contracts with the Township to notify the Township in writing of any changes to the information contained herein; that I am aware that it is a criminal offense to make a false statement or misrepresentation in this certification, and if I do so, I am subject to criminal prosecution under the law and that it will constitute a material breach of my agreement(s) with the, permitting the Township to declare any contract(s) resulting from this certification void and unenforceable.

Full Name (Print):		Title:	
Signature:		Date:	



STANDARD BID DOCUMENT REFERENCE	
Name of Form:	FEDERAL NON-DEBARMENT CERTIFICATION
Statutory Reference:	N.J.S.A. 52:32-44.1 (P.L. 2019, c.406)
Description:	Meets statutory criteria for certification of non-debarment by a federal government agency.

Summary of the Certification Requirements under N.J.S.A. 52:32-44.1

Pursuant to state law any natural person, company, firm, association, corporation, or other entity prohibited, or “debarred,” from contracting with the federal government agencies, shall also be prohibited from contracting for public work in the state of New Jersey. This prohibition also extends to any affiliate organization(s) held by or subject to the control of an entity of that prohibited person or entity.

Prior to awarding a contract for public work a local units must obtain written certification from the contracting person or entity through the form below, attesting to their non-debarment from contracting with federal government agencies. Contracting units are reminded that they must fill-in the boilerplate information in the certification sections of Parts II through IV regarding their name and type of contracting unit before using the form.



**CERTIFICATION OF NON-DEBARMENT  
FOR FEDERAL GOVERNMENT CONTRACTS**  
N.J.S.A. 52:32-44.1 (P.L. 2019, c.406)

This certification shall be completed, certified to, and submitted to the contracting unit prior to contract award, except for emergency contracts where submission is required prior to payment.

PART I: VENDOR INFORMATION	
Individual or Organization Name	
Address of Individual or Organization	
DUNS Code (if applicable)	
CAGE Code (if applicable)	
Check the box that represents the type of business organization:	

- Sole Proprietorship (skip Parts III and IV)   
  Non-Profit Corporation (skip Parts III and IV)  
 For-Profit Corporation (any type)   
  Limited Liability Company (LLC)   
  Partnership  
 Limited Partnership               
  Limited Liability Partnership (LLP)  
 Other (be specific): \_\_\_\_\_

PART II – CERTIFICATION OF NON-DEBARMENT: Individual or Organization			
I hereby certify that the individual or organization listed above in Part I is not debarred by the federal government from contracting with a federal agency. I further acknowledge: that I am authorized to execute this certification on behalf of the above-named organization; that the Township of Willingboro is relying on the information contained herein and that I am under a continuing obligation from the date of this certification through the date of contract award by the Township of Willingboro to notify the Township of Willingboro in writing of any changes to the information contained herein; that I am aware that it is a criminal offense to make a false statement or misrepresentation in this certification, and if I do so, I am subject to criminal prosecution under the law and that it will constitute a material breach of my agreement(s) with the Township of Willingboro, permitting the Township of Willingboro to declare any contract(s) resulting from this certification void and unenforceable.			
Full Name (Print):		Title:	
Signature:		Date:	



**PART III – CERTIFICATION OF NON-DEBARMENT: Individual or Entity Owning Greater than 50 Percent of Organization**

**Section A (Check the Box that applies)**

<input type="checkbox"/>          <input type="checkbox"/>	Below is the name and address of the stockholder in the corporation who owns more than 50 percent of its voting stock, or of the partner in the partnership who owns more than 50 percent interest therein, or of the member of the limited liability company owning more than 50 percent interest therein, as the case may be.
--	---

Name of Individual or Organization	
------------------------------------	--

Home Address (for Individual) or Business Address	
---	--

OR

<input type="checkbox"/>          <input type="checkbox"/>	No one stockholder in the corporation owns more than 50 percent of its voting stock, or no partner in the partnership owns more than 50 percent interest therein, or no member in the limited liability company owns more than 50 percent interest therein, as the case may be.
--	---

**Section B (Skip if no Business entity is listed in Section A above)**

<input type="checkbox"/>          <input type="checkbox"/>	Below is the name and address of the stockholder in the corporation who owns more than 50 percent of the voting stock of the organization’s parent entity, or of the partner in the partnership who owns more than 50 percent interest in the organization’s parent entity, or of the member of the limited liability company owning more than 50 percent interest in organization’s parent entity, as the case may be.
--	---

Stockholder/Partner/Member Owning Greater Than 50 Percent of Parent Entity	
--	--

Home Address (for Individual) or Business Address	
---	--

OR

<input type="checkbox"/>          <input type="checkbox"/>	No one stockholder in the parent entity corporation owns more than 50 percent of its voting stock, no partner in the parent entity partnership owns more than 50 percent interest therein, or no member in the parent entity limited liability company owns more than 50 percent interest therein, as the case may be.
--	--





**Section C – Part III Certification**

I hereby certify that no individual or organization that is debarred by the federal government from contracting with a federal agency owns greater than 50 percent of the Organization listed above in Part I or, if applicable, owns greater than 50 percent of a parent entity of the Organization listed above in Part I. I further acknowledge: that I am authorized to execute this certification on behalf of the above-named organization; that the Township of Willingboro is relying on the information contained herein and that I am under a continuing obligation from the date of this certification through the date of contract award with the Township of Willingboro to notify the Township of Willingboro in writing of any changes to the information contained herein; that I am aware that it is a criminal offense to make a false statement or misrepresentation in this certification, and if I do so, I am subject to criminal prosecution under the law and that it will constitute a material breach of my agreement(s) with the Township of Willingboro permitting the Township of Willingboro to declare any contract(s) resulting from this certification void and unenforceable.

Full Name (Print):		Title:	
Signature:		Date:	

**Part IV – CERTIFICATION OF NON-DEBARMENT: Contractor – Controlled Entities**

**Section A**

<input type="checkbox"/> <input type="checkbox"/> <input type="checkbox"/>	Below is the name and address of the corporation(s) in which the Organization listed in Part I owns more than 50 percent of voting stock, or of the partnership(s) in which the Organization listed in Part I owns more than 50 percent interest therein, or of the limited liability company or companies in which the Organization listed above in Part I owns more than 50 percent interest therein, as the case may be.
Name of Business Entity	Business Address
**Add additional sheets if necessary**	
OR	
<input type="checkbox"/> <input type="checkbox"/>	The Organization listed above in Part I does not own greater than 50 percent of the voting stock in any corporation and does not own greater than 50 percent interest in any partnership or any limited liability company.



Section B (skip if no business entities are listed in Section A of Part IV)	
<input type="checkbox"/>	Below are the names and addresses of any entities in which an entity listed in Part III A owns greater than 50 percent of the voting stock (corporation) or owns greater than 50 percent interest (partnership or limited liability company).
Name of Business Entity Controlled by Entity Listed in Section A of Part IV	Business Address
**Add additional Sheets if necessary**	
OR	
<input type="checkbox"/>	No entity listed in Part III A owns greater than 50 percent of the voting stock in any corporation or owns greater than 50 percent interest in any partnership or limited liability company.
Section C – Part IV Certification	
<p>I hereby certify that the Organization listed above in Part I does not own greater than 50 percent of any entity that that is debarred by the federal government from contracting with a federal agency and, if applicable, does not own greater than 50 percent of any entity that in turns owns greater than 50 percent of any entity debarred by the federal government from contracting with a federal agency. I further acknowledge: that I am authorized to execute this certification on behalf of the above-named organization; that the Township of Willingboro is relying on the information contained herein and that I am under a continuing obligation from the date of this certification through the date of contract award by the Township of Willingboro to notify the Township of Willingboro in writing of any changes to the information contained herein; that I am aware that it is a criminal offense to make a false statement or misrepresentation in this certification, and if I do so, I am subject to criminal prosecution under the law and that it will constitute a material breach of my agreement(s) with the Township of Willingboro, permitting the Township of Willingboro to declare any contract(s) resulting from this certification void and unenforceable.</p>	
Full Name (Print):	Title:
Signature:	Date:



**SECTION J**

**CONTRACT DOCUMENTS**

\* \* \*

**PERFORMANCE BOND**



CONTRACT

THIS AGREEMENT, made and executed at the Township of Willingboro,  
Burlington County, New Jersey, this \_\_\_\_\_ day of \_\_\_\_\_, 20\_\_\_\_  
by and between the Township of Willingboro, hereinafter called the OWNER and

\_\_\_\_\_  
\_\_\_\_\_  
\_\_\_\_\_

hereinafter called the "Contractor."

WITNESSETH: That the said Contractor has agreed and by these presents does agree with the OWNER for the prices stipulated in and proposal herein contained or hereunto annexed and under the penalty expressed in bonds bearing even date with these presents, and herein contained or hereunto annexed, to furnish at his own cost and expense all the necessary materials, labor, superintendence, tools and appliances and shall execute, construct and finish and test in expeditious and workmanlike manner, the

Township of Willingboro

Contract No. WTCEX21015, Sound and Lighting System Equipment

and appurtenances commencing the work within ten (10) days from the date of notice from the office of the ENGINEER to commence work and executing the same within the time and in the manner specified and in conformity with the requirements set forth in the specifications herein contained or hereunto attached and in accordance with the contract drawings of said work on file in the office of the OWNER and all to the acceptance of the said OWNER.





CONTRACT (Continued)

The Contractor shall proceed with the said work in a prompt and diligent manner and shall do the several parts thereof at such times in such order as the ENGINEER may direct. Further, he shall complete the whole of said work through final restoration in accordance with the specifications and contract drawings to the satisfaction of the OWNER, and within the calendar days specified within the Proposal section from the date of notice to begin work, and in default of completion within the time as fixed, the Contractor shall pay the OWNER an amount equal to Five Hundred Dollars (\$100.00) for each and every day (Sundays and legal holidays excepted) the completion of the work may be delayed beyond the date fixed, in the manner and as stipulated. Contract period, as stated, acknowledges delay time for delivery of equipment and extension of Contract period will be allowed as appropriate.

The OWNER shall not be liable to the Contractor for any neglect, default, delay or interference of or by any other contractor, nor shall any such neglect, default, delay or interference of any other contractor, or alteration which may be required in said work, release the Contractor from the obligation to finish the said work within the time aforesaid or from the damages to be paid in default thereof.

Name and address of each person or company interested in the Contract:

---

---

---

---

---

It is hereby mutually agreed that the OWNER is to pay and the Contractor is to receive the prices stipulated in the Proposal herein contained or hereto annexed, as full compensation for furnishing all materials and labor in building, constructing and testing, and in all respects completing the herein specified and for fully complying with the terms and conditions of this Contract.



## CONTRACT (Continued)

The status of the Contractor in the work to be performed by him under the Contract is that of an independent contractor. As such, the work, in every respect, from the execution of the Contract and during progress of the work thereunder, and until final acceptance, shall be under the charge and in care of the Contractor and at his risk. He shall properly safeguard against any or all injury to the public, the public and private property, materials and things, and, as such, the Contractor alone shall be responsible for any and all damage, loss or injury to persons or property that may arise, or be incurred in, or during the conduct or progress of said work without regard to whether the Contractor, his subcontractors, agents or employees, have been negligent. The Contractor shall keep the OWNER and ENGINEER free and discharged of any and all responsibility and liability therefor of any sort or kind whatsoever. The Contractor shall assume all responsibility for risks and casualties of every description and for any or all damage, loss or injury to persons or property arising out of the nature of the work from the action of the elements, or from any unforeseen or unusual difficulty or circumstance. The Contractor shall assume and be liable for all blame and loss of whatsoever nature by reason of neglect or violation of any State, County or local laws, statutes, ordinances or any and all rules and regulations promulgated thereunder. The Contractor shall indemnify and save harmless the OWNER and ENGINEER and all of the respective officers, agents and employees from all liability or suits or actions at law or in equity of any kind whatsoever arising from the failure of the Contractor to comply with the terms and conditions of the Contract, the plans and specifications or State statutes or local ordinances or any rules and regulations promulgated, in accordance with the provisions of such statutes or ordinances by the State of New Jersey or any municipality thereof or by any department or agency of any or all thereof, and the Contractor shall, if required by the OWNER or ENGINEER, produce evidence of settlement of any such action before final payment under the Contract shall be made by the OWNER.

The Contractor shall, unless otherwise specified, maintain and pay for such insurance, issued in the name of the OWNER as will protect the OWNER from contingent liability under this Contract and the OWNER's right to enforce against the Contractor any provision of this article shall be contingent upon the full compliance by the OWNER with the terms of such insurance policy or policies, a copy of which shall be deposited with the OWNER.

### **MANDATORY EQUAL EMPLOYMENT OPPORTUNITY LANGUAGE (N.J.S.A. 10:53-1 et seq., N.J.A.C. 17:27)**

During the performance of this contract, the contractor agrees as follows:

The contractor or subcontractor, where applicable, will not discriminate against any employee or applicant for employment because of age, race, creed, color, national origin, ancestry, marital status, affectional or sexual orientation or sex. Except with respect to affectional or sexual orientation, the contractor will take affirmative action to ensure that such applicants are recruited and employed, and that employees are treated during employment, without regard to their age, race, creed, color, national origin, ancestry, marital status, affectional or sexual orientation or sex. Such action shall include, but not be limited to the following: employment, upgrading, demotion, or transfer; recruitment or recruitment advertising; layoff or termination; rates of pay or other forms of compensation; and selection for training, including apprenticeship. The



contractor agrees to post in conspicuous places, available to employees and applicants for employment, notices to be provided by the Public Agency Compliance Officer setting forth provisions of this nondiscrimination clause.

The contractor or subcontractor, where applicable will, in all solicitations or advertisements for employees placed by or on behalf of the contractor, state that all qualified applicants will receive consideration for employment without regard to age, race, creed, color, national origin, ancestry, marital status, affectional or sexual orientation or sex.

The contractor or subcontractor, where applicable, will send to each labor union or representative of workers with which it has a collective bargaining agreement or other contract or understanding, a notice, to be provided by the agency contracting officer advising the labor union or workers' representative of the contractor's commitments under this act and shall post copies of the notice in conspicuous places available to employees and applicants for employment.

The contractor or subcontractor where applicable, agrees to comply with any regulations promulgated by the Treasurer pursuant to **N.J.S.A. 10:5-31 et seq.**, as amended and supplemented from time to time and the Americans with Disabilities Act.

When hiring or scheduling workers in each construction trade, the contractor or subcontractor agrees to make good faith efforts to employ minority and women workers in each construction trade consistent with the applicable employment goal prescribed by **N.J.A.C. 17:27-7.3**; provided, however, that the Division may, in its discretion, exempt a contractor or subcontractor from compliance with the good faith procedures prescribed by the following provisions, A, B and C, as long as the Division is satisfied that the contractor or subcontractor is employing workers provided by a union which provides evidence, in accordance with standards prescribed by the Division, that its percentage of active "card carrying" members who are minority and women workers is equal to or greater than the applicable employment goal established in accordance with **N.J.A.C. 17:27-7.3**.

The contractor or subcontractor agrees that a good faith effort shall include compliance with the following procedures:

(A) If the contractor or subcontractor has a referral agreement or arrangement with a union for a construction trade, the contractor or subcontractor shall, within three business days of the contract award, seek assurances from the union that it will cooperate with the contractor or subcontractor as it fulfills its affirmative action obligations under this contract and in accordance with the rules promulgated by the Treasurer pursuant to **N.J.S.A. 10:5-31 et. seq.**, as supplemented and amended from time to time and the Americans with Disabilities Act. If the contractor or subcontractor is unable to obtain said assurances from the construction trade union at least five business days prior to the commencement of construction work, the contractor or subcontractor agrees to attempt to hire or schedule minority and women workers directly, consistent with the applicable employment goal. If the contractor's or subcontractor's prior experience with a construction trade union, regardless of whether the union has provided said assurances, indicates a significant possibility that the trade union will not refer sufficient minority and women workers consistent with the applicable employment goal, the contractor or subcontractor agrees to be prepared to hire or schedule minority and women workers directly,



consistent with the applicable employment goal, by complying with the hiring or scheduling procedures prescribed under (B) below; and the contractor or subcontractor further agrees to take said action immediately if it determines or is so notified by the Division that the union is not referring minority and women workers consistent with the applicable employment goal.

(B) If the hiring or scheduling of a workforce consistent with the employment goal has not or cannot be achieved for each construction trade by adhering to the procedures of (A) above, or if the contractor does not have a referral agreement or arrangement with a union for a construction trade, the contractor or subcontractor agrees to take the following actions consistent with the applicable county employment goals:

(1) To notify the public agency compliance officer, the Division, and minority and women referral organizations listed by the Division pursuant to N.J.A.C. 17:27-5.3, of its workforce needs, and request referral of minority and women workers;

(2) To notify any minority and women workers who have been listed with it as awaiting available vacancies;

(3) Prior to commencement of work, to request that the local construction trade union refer minority and women workers to fill job openings, provided the contractor or subcontractor has a referral agreement or arrangement with a union for the construction trade;

(4) To leave standing requests for additional referral to minority and women workers with the local construction trade union, provided the contractor or subcontractor has a referral agreement or arrangement with a union for the construction trade, the State Training and Employment Service and other approved referral sources in the area until such time as the workforce is consistent with the employment goal;

(5) If it is necessary to lay off some of the workers in a given trade on the construction site, to assure, consistent with the applicable State and Federal statutes and court decisions, that sufficient minority and women employees remain on the site consistent with the employment goal; and to employ any minority and women workers so laid off by the contractor on any other construction site on which its workforce composition is not consistent with an employment goal established pursuant to rules implementing **N.J.S.A. 10:5-31 et. seq.**;

(6) To adhere to the following procedure when minority and women workers apply or are referred to the contractor or subcontractor:

(i) If said individuals have never previously received any document or certification signifying a level of qualification lower than that required in order to perform the work of the construction trade, the contractor or subcontractor shall determine the qualifications of such individuals and if the contractor's or subcontractor's workforce in each construction trade is not consistent with the applicable employment goal; it shall hire or schedule those individuals who satisfy appropriate qualification standards. However,





a contractor or subcontractor shall determine that the individual at least possesses the requisite skills, and experience recognized by a union, apprentice program or a referral agency, provided the referral agency is acceptable to the Division. If necessary, the contractor or subcontractor shall hire or schedule minority and women workers who qualify as trainees pursuant to these rules. All of the requirements, however, are limited by the provisions of (C) below.

(ii) If the contractor's or subcontractor's workforce is consistent with the applicable employment goal, the name of any interested women or minority individual shall be maintained on a waiting list for the first consideration, in the event the contractor's or subcontractor's workforce is no longer consistent with the applicable employment goal.

(iii) If, for any reason, said contractor or subcontractor determines that a minority individual or a woman is not qualified or if the individual qualifies as an advanced trainee or apprentice, the contractor or subcontractor shall inform the individual in writing of the reasons for the determination, maintain a copy of the determination in its files, and send a copy to the public agency compliance officer and to the Division.

(7) To keep a complete and accurate record of all requests made for the referral of workers in any trade covered by the contract, on forms made available by the Division and submitted promptly to the Division upon request.

( C ) The contractor or subcontractor agrees that nothing contained in (B) above shall preclude the contractor or subcontractor from complying with the union hiring hall or apprenticeship policies in any applicable collective bargaining agreement or union hiring hall arrangement, and, where required by custom or agreement, it shall send journeymen and trainees to the union for referral, or to the apprenticeship program for admission, pursuant to such agreement or arrangement. However, where the practices of a union or apprenticeship program will result in the exclusion of minorities and women or the failure to refer minorities and women consistent with the county employment goal, the contractor or subcontractor shall consider for employment persons referred pursuant to (B) above without regard to such agreement or arrangement; provided further, however, that the contractor or subcontractor shall not be required to employ women and minority advanced trainees and trainees in numbers which result in the employment of advanced trainees and trainees as a percentage of the total workforce for the construction trade, which percentage significantly exceeds the apprentice to journey worker ratio specified in the applicable collective bargaining agreement, or in the absence of a collective bargaining agreement , exceeds the ratio established by practice in the area for said construction trade. Also, the contractor or subcontractor agrees that, in implementing the procedures of (B) above it shall, where applicable, employ minority and women workers residing within the geographical jurisdiction of the union.



After notification of award, but prior to signing a construction contract, the contractor shall submit to the public agency compliance officer and the Division an initial project workforce report (Form AA 201) provided to the public agency by the Division for distribution to and completion by the contractor, in accordance with N.J.A.C. 17:27-7.3

The contractor also agrees to submit a copy of the Monthly Project Workforce Report once a month thereafter for the duration of this contract to the Division and to the public agency compliance officer.

The contractor agrees to cooperate with the public agency in the payment of budgeted funds, as is necessary, for on-the-job and/or off-the-job programs for outreach and training of minorities and women.

(D). The contractor and its subcontractors shall furnish such reports or other documents to the Division of Contract Compliance & EEO as may be requested by the Division from time to time in order to carry out the purposes of these regulations, and public agencies shall furnish such information as may be requested by the Division of Contract Compliance & EEO for conducting a compliance investigation pursuant to **Subchapter 10 of the Administrative Code at N.J.A.C. 17:27.**



CONTRACT (Continued)

Subject to the applicable provisions of the law, this Contract shall be in full force and effect as a contract from and after the date when a fully executed and approved counterpart hereof is delivered to the Contractor.

In witness whereof: The parties hereto have executed this Agreement the day and year first mentioned above.

Attest \_\_\_\_\_ By \_\_\_\_\_  
Everett Falt Kaya McIntosh  
Clerk Mayor

(SEAL)

\_\_\_\_\_ Date \_\_\_\_\_ Contracting Firm

Attest \_\_\_\_\_ By \_\_\_\_\_  
Principal of Contracting Firm

(SEAL)



CONTRACT (Continued)

ACKNOWLEDGMENT OF THE MAYOR  
(FOR EXECUTION OF CONTRACT)

STATE OF NEW JERSEY   )  
  )  
COUNTY OF Burlington   )

On this \_\_\_\_\_ day of \_\_\_\_\_, 20\_, before me personally came and appeared Kaya McIntosh to me known, who, being by me duly sworn, did depose and say that she is the Mayor of the Township of Willingboro described in and who executed the foregoing instrument; that she knows the seal of the said Municipality; that one of the seals affixed to said instrument is such seal; that it was so affixed by order of the said Municipality and she signed her name thereto by like order.

\_\_\_\_\_ (SEAL)  
Notary Public

ACKNOWLEDGMENT OF THE CLERK  
(FOR EXECUTION OF CONTRACT)

STATE OF NEW JERSEY   )  
  )  
COUNTY OF Burlington   )

On this \_\_\_\_\_ day of \_\_\_\_\_, 20\_, before me personally came and appeared Everett Falt, to me known to be the Clerk of the Township of Willingboro, described in and who executed the foregoing instrument, and she acknowledged to me that she executed the same as and for the act and deed of the said Municipality.

\_\_\_\_\_ (SEAL)  
Notary Public





CONTRACT (Continued)

ACKNOWLEDGMENT OF CONTRACTOR, IF A CORPORATION  
(FOR EXECUTION OF CONTRACT)

STATE OF \_\_\_\_\_ )  
 )

COUNTY OF \_\_\_\_\_ )

On this \_\_\_\_\_ day of \_\_\_\_\_, 20\_\_\_\_, before me personally came and appeared \_\_\_\_\_, to me known, who, being by me duly sworn, did depose and say that he is the \_\_\_\_\_ of \_\_\_\_\_, the corporation described in and which executed the foregoing instrument; that he knows the seal of the said Corporation; that one of the seals affixed to said instrument is such seal; that it was so affixed by order of the said Corporation and he signed his name thereto by like order.

\_\_\_\_\_  
Notary Public (SEAL)

ACKNOWLEDGMENT OF CONTRACTOR, IF A FIRM OR PARTNERSHIP  
(FOR EXECUTION OF CONTRACT)

STATE OF \_\_\_\_\_ )  
 )

COUNTY OF \_\_\_\_\_ )

On this \_\_\_\_\_ day of \_\_\_\_\_, 20\_\_\_\_, before me personally came and appeared \_\_\_\_\_, to me known to be one of the members of the firm of \_\_\_\_\_ described in and who executed the foregoing instrument, and he acknowledged to me that he executed the same as and for the act and deed of the said firm.

\_\_\_\_\_  
Notary Public (SEAL)



CONTRACT (Continued)

ACKNOWLEDGMENT OF CONTRACTOR, IF AN INDIVIDUAL  
(FOR EXECUTION OF CONTRACT)

STATE OF \_\_\_\_\_ )

)

COUNTY OF \_\_\_\_\_ )

On this \_\_\_\_\_ day of \_\_\_\_\_, 20\_\_, before me personally came and appeared \_\_\_\_\_, to me known to be the person described in and who executed the foregoing instrument and acknowledged that he executed the same.

\_\_\_\_\_ (SEAL)  
Notary Public



CONTRACT (Continued)

PERFORMANCE BOND

CONTRACT NO. WTCEX 21015 –

Sound and Lighting Equipment

BOND NO.

Know all men by these presents, that we, the undersigned \_\_\_\_\_, as principal and \_\_\_\_\_, as sureties, are hereby held and firmly bound unto the Township of Willingboro in the penal sum of \_\_\_\_\_ dollars, for the payment of which well and truly to be made, we hereby jointly and severally bind ourselves, our heirs, executors, administrators, successors and assigns.

Signed this \_\_\_\_\_ day of \_\_\_\_\_, 20\_\_

The condition of the above obligation is such that whereas, the above named principal did on the day of \_\_\_\_\_, 20\_\_, enter into a contract with the Township of Willingboro, which said contract is made a part of this the bond the same as though set forth herein;

Now, if the said \_\_\_\_\_ shall well and faithfully do and perform the things agreed to be done and performed according to the terms of said contract, and shall pay all lawful claims of subcontractors, materialmen, laborers, persons, firms or corporations for labor performed or materials, provisions, provender or other supplies or teams, fuels, oils, implements or machinery furnished, used or consumed in the carrying forward, performing or completing of said contract, we agreeing and assenting that this undertaking shall be for the benefit of any subcontractor, materialman, laborer, person, firm or corporation having a just claim, as well as for the obligee herein; it being expressly understood and agreed that the liability of the surety for any and all claims hereunder shall in no event exceed the penal amount of this obligation as herein stated.

The said surety hereby stipulates and agrees that no modifications, omissions or additions in or to the terms of the said contract or in or to the plans or specifications therefor shall in anywise affect the obligation of said surety on its bond.



CONTRACT (Continued)

The Principal and the Surety agree that in case of default in and/or any action arising out of this Bond, the Obligee or any person, association, partnership and/or corporation who shall be entitled to institute and maintain an action upon this Bond, as above provided, may use, for the purpose of the establishment of the claim, a copy of this Bond, duly certified by the Obligee to be true and correct; and the Principal and the Surety agree that any action instituted upon any part of this Bond shall not be a bar to any subsequent action upon the same part or any other part of this Bond.

Each reference in this Bond to the Obligee shall also include the officers, employees and representatives of said Obligee.

It is the intention of the parties hereto to be legally bound by this instrument.

IN WITNESS THEREOF THE said Principal and Surety have duly executed this Bond in triplicate under seal and day and year first above written.

SIGNED, SEALED AND DATED THIS \_\_\_\_\_ day of \_\_\_\_\_, 20\_.

\_\_\_\_\_  
Principal

Attest: \_\_\_\_\_

By \_\_\_\_\_ (L.S.)

\_\_\_\_\_  
Title of Officer

\_\_\_\_\_  
Secretary

(SEAL)

\_\_\_\_\_  
Surety

\_\_\_\_\_  
Address

Attest: \_\_\_\_\_

By \_\_\_\_\_ (L.S.)

\_\_\_\_\_  
Title of Officer

(SEAL)





CONTRACT (Continued)

ACKNOWLEDGMENT OF PRINCIPAL, IF A CORPORATION  
(FOR EXECUTION OF BOND)

STATE OF \_\_\_\_\_ )  
 )  
COUNTY OF \_\_\_\_\_ )

On this \_\_\_\_\_ day of \_\_\_\_\_, 20\_\_\_\_, before me personally came and appeared \_\_\_\_\_, to me known, who being by me duly sworn did depose and say that he resides at \_\_\_\_\_ that he is the \_\_\_\_\_ of \_\_\_\_\_, the Corporation described in and which executed the foregoing instrument; that he knows the seal of said Corporation; that one of the impressions affixed to said instrument is an impression of such seal; that it was so affixed by order of the directors of said Corporation, and that he signed his name thereto by like order.

\_\_\_\_\_ (SEAL)  
Notary Public

ACKNOWLEDGMENT OF PRINCIPAL, IF A FIRM OR PARTNERSHIP  
(FOR EXECUTION OF BOND)

STATE OF \_\_\_\_\_ )  
 )  
COUNTY OF \_\_\_\_\_ )

On this \_\_\_\_\_ day of \_\_\_\_\_, 20\_\_\_\_, before me personally came and appeared \_\_\_\_\_, to me known to be one of the members of the firm of \_\_\_\_\_

described in and who executed the foregoing instrument and he acknowledged to me that he executed the same as and for the act and deed of said firm.

\_\_\_\_\_ (SEAL)  
Notary Public



CONTRACT (Continued)

ACKNOWLEDGMENT OF PRINCIPAL, IF AN INDIVIDUAL  
(FOR EXECUTION OF BOND)

STATE OF \_\_\_\_\_ )  
  )  
COUNTY OF \_\_\_\_\_ )

On this \_\_\_\_\_ day of \_\_\_\_\_, 20\_\_\_\_, before me personally came and appeared  
\_\_\_\_\_, to me known to be the person described in  
and who executed the foregoing instrument and acknowledged that he executed same.

\_\_\_\_\_ (SEAL)  
Notary Public

ACKNOWLEDGMENT OF SURETY COMPANY  
(FOR EXECUTION OF BOND)

STATE OF \_\_\_\_\_ )  
  )  
COUNTY OF \_\_\_\_\_ )

On this \_\_\_\_\_ day of \_\_\_\_\_, 20\_\_\_\_, before me personally came  
\_\_\_\_\_, to me personally known to me to be the  
\_\_\_\_\_ of the Corporation described in and which  
executed the with instrument, who being by me duly sworn, did depose and say that he resides at  
\_\_\_\_\_, that he is the  
\_\_\_\_\_ of the said Corporation; that he knows the seal of said Corporation; that the seal  
affixed to the said instrument is such corporate seal; that it was so affixed by order of the Board of  
Directors of said Corporation and that he signed his name thereto by like order.

\_\_\_\_\_ (SEAL)  
Notary Public



FORM OF CONTRACTOR'S CERTIFICATE

STATE OF \_\_\_\_\_ )  
                                      )  
COUNTY OF \_\_\_\_\_ )

Before me, the undersigned, a Notary Public in and for said County and State, personally appeared \_\_\_\_\_, who being duly sworn according to law, deposes and says that he/she has complied with the requirements of the New Jersey Department of Labor and Industry Rules and Regulations pertaining to Prevailing Wage Rates and that all labor, material, outstanding claims and indebtedness of whatsoever nature arising out of the performance of the contract of

\_\_\_\_\_  
\_\_\_\_\_  
\_\_\_\_\_

with the \_\_\_\_\_ have been paid. He/she further states that all workmen have received all wages and benefits, and that they have full knowledge of contents of this statement and the same is true to his/their knowledge.

\_\_\_\_\_  
Contractor

Sworn to me and subscribed before me this \_\_\_\_\_ day of \_\_\_\_\_, 20\_\_\_\_\_.

